

**PUBLIC VERSION**

**UNITED STATES INTERNATIONAL TRADE COMMISSION  
Washington, D.C.**

**In the Matter of**

**CERTAIN SLEEP-DISORDERED  
BREATHING TREATMENT SYSTEMS  
AND COMPONENTS THEREOF**

**Investigation No. 337-TA-879**

**ADVISORY OPINION**

**I. INTRODUCTION**

On December 11, 2013, the Commission determined to institute an advisory opinion proceeding (“AOP”) in this investigation to determine whether certain redesigned sleep-disordered breathing treatment systems and components imported by respondents Apex Medical Corp. of New Taipei City, Taiwan and Apex Medical USA Corp. of Brea, California (collectively, “Apex”) are covered by the Consent Order issued by the Commission on August 8, 2013. 78 *Fed. Reg.* 76320-21 (Dec. 17, 2013). Complainants ResMed Corp. of San Diego, California; ResMed Inc. of San Diego, California; and ResMed Ltd. of Australia (collectively, “ResMed”) and the Office of Unfair Import Investigations (“OUII”) participated in the AOP.

On June 3, 2014, the presiding administrative law judge (“ALJ”) issued an initial advisory opinion (“IAO”). The ALJ placed the burden of proof on the patent owner, ResMed, in view of the Supreme Court’s decision in *Medtronic, Inc. v. Mirowski Family Ventures, LLC*, 134 S. Ct. 843 (2014). The ALJ found that Apex’s redesigned iCH and XT humidifiers are covered by the Consent Order, and its WiZARD 220 mask is not covered by the Consent Order.

For the reasons stated below, the Commission has determined to reverse the ALJ’s decision to place the burden of proof in this proceeding on the patent owner, ResMed. With

## PUBLIC VERSION

Apex carrying the burden of proving noninfringement, the Commission has determined to adopt, with modified reasoning, the ALJ's finding that Apex's redesigned iCH humidifier is covered by the Consent Order and Apex's redesigned WiZARD 220 mask is not covered by the Consent Order. The Commission has also determined to reverse the ALJ's finding that Apex's redesigned XT humidifier is covered by the Consent Order.

## II. BACKGROUND

The Commission instituted this investigation on April 25, 2013, based on a complaint filed on March 28, 2013, and supplemented on April 19, 2013, on behalf of ResMed. *78 Fed. Reg.* 25475 (May 1, 2013). The complaint alleged violations of section 337 of the Tariff Act of 1930, as amended, 19 U.S.C. § 1337, in the sale for importation, importation, or sale within the United States after importation of certain sleep-disordered breathing treatment systems and components thereof by reason of infringement of claims 1, 2, 4, 5, 17, and 28 of U.S. Patent No. 6,216,691 ("the '691 patent"); claims 1 and 20 of U.S. Patent No. 6,935,337 ("the '337 patent"); claim 15 of U.S. Patent No. 7,159,587 ("the '587 patent"); claims 1, 5, 6, 11, 12, 18–20, 35, and 36 of U.S. Patent No. 7,487,772 ("the '772 patent"); claims 1–7 of U.S. Patent No. 7,614,398 ("the '398 patent"); claims 59, 60, 63, and 72–75 of U.S. Patent No. 7,743,767 ("the '767 patent"); and claims 17, 21–24, 29, and 32–37 of U.S. Patent No. 7,997,267 ("the '267 patent"). The Commission's notice of investigation named as respondents Apex, and Medical Depot Inc., d/b/a Drive Medical Design & Manufacturing of Port Washington, New York. OUII participated in the original investigation.

Medical Depot Inc. and Apex were terminated from the original investigation on the basis of consent orders. Order Nos. 8 (unreviewed by the Commission, July 18, 2013) and 11

## PUBLIC VERSION

(unreviewed by the Commission, Aug. 8, 2013). Under the terms of the Consent Order issued by the Commission on August 8, 2013, Apex agreed that:

A. Effective immediately upon the entry of this Consent Order, Apex shall not sell for importation, import, or sell after importation any sleep-disordered breathing treatment systems and components thereof that infringe the Asserted Patent Claims (collectively, “Subject Articles”), directly or indirectly, and shall not aid, abet, encourage, participate in, or induce the sale for importation, the importation, or the sale after importation except under consent or license from ResMed.

B. Effective immediately upon the entry of this Consent Order, Apex Medical USA Corp. shall cease and desist from importing and distributing Subject Articles covered by the Asserted patent claims.

Order No. 11 (July 17, 2013).

On September 23, 2013, Apex filed a request for an AOP in the investigation pursuant to Commission Rule 210.79 (19 C.F.R. § 210.79). The Commission granted Apex’s request on December 11, 2013. *78 Fed. Reg.* 76320-21 (Dec. 17, 2013). The AOP was instituted to determine whether Apex’s redesigned sleep-disordered breathing treatment systems infringe claims 1, 2, 4, 5, 17, and 28 of the ’691 patent, claims 1 and 20 of the ’337 patent, claim 15 of the ’587 patent, claims 1, 5, 6, 11, 12, 18-20, 35, and 36 of the ’772 patent, claims 1-7 of the ’398 patent, claims 59, 60, 63, and 72-75 of the ’767 patent, and claims 17, 21-24, 29, and 32-37 of the ’267 patent. The Commission certified the AOP to the chief ALJ for assignment to a presiding ALJ for the appropriate proceeding and issuance of an IAO. The Commission directed that the AOP was to be completed as expeditiously as practicable. *See* Commission Order (Dec. 11, 2013).

The presiding ALJ conducted a Markman hearing on March 10, 2014, and an evidentiary hearing from March 10 to March 12, 2014. In light of a Joint Stipulation and Apex’s withdrawal of certain claims, the parties addressed three of Apex’s design arounds: (1) the iCH humidifier (JPX-1); (2) the XT humidifier (JPX-2); and (3) the WiZARD 220 mask (JPX-4). *See*

## PUBLIC VERSION

Respondents Apex Medical Corp. and Apex Medical USA Corp.’s Petition for Review of Initial Advisory Opinion (“APet.”) at 8-10. The parties also narrowed the issues at the evidentiary hearing to: (1) whether Apex’s redesigned iCH and XT humidifiers infringe claim 20 of the ’337 patent; and (2) whether Apex’s redesigned WiZARD 220 mask infringes claim 15 of the ’587 patent.

With the burden of proof placed on ResMed, the ALJ determined that Apex’s iCH and the XT humidifiers are covered, and its WiZARD 220 mask is not covered, by the Consent Order. Specifically, the ALJ found that Apex’s iCH humidifier infringes claim 20 of the ’337 patent both literally and under the doctrine of equivalents and Apex’s XT humidifier infringes claim 20 of the ’337 patent under the doctrine of equivalents. The ALJ also found that Apex’s WiZARD 220 mask does not infringe claim 15 of the ’587 patent.

The IA and ResMed asked the Commission to review the ALJ’s reliance on the Supreme Court’s rationale in *Medtronic* in finding that the complainant/patentee – not the party seeking the advisory opinion – bears the burden of proving that respondents’ redesigned products infringe. ResMed also asked the Commission to review the ALJ’s construction of the limitation “a gas washout vent portion” in claim 15 of the ’587 patent. The IA and Apex asked the Commission to review the ALJ’s finding that the XT humidifier satisfies the “top cover” limitation in claim 20 of the ’337 patent under the doctrine of equivalents. Apex also asked the Commission to review the ALJ’s infringement findings with respect to its iCH humidifier, and the ALJ’s finding that its WiZARD 220 mask meets the limitation “the vent portion has a thickness of less than about 3 mm” in claim 15 of the ’587 patent. The parties filed their responses to the petitions for review on June 23, 2014.

The Commission provides its determination and analysis with respect to the reviewed issues in this AOP herein. Any findings, conclusions, and supporting analysis by the ALJ that are not inconsistent with our analysis and conclusions below are adopted by the Commission.

## PUBLIC VERSION

### III. BURDEN OF PROOF IN ADVISORY OPINION PROCEEDINGS

The Commission places the burden of proof in AOPs on the party requesting an advisory opinion. *See, e.g., Certain Condensers, Parts Thereof, and Products Containing Same, Including Air Conditioners for Automobiles*, Inv. No. 337-TA-334, IAO at 2, 20 (Mar. 14, 2000) (adopted by the Commission on May 1, 2000) (“[Respondent] has the burden of proving non-infringement, having requested an advisory opinion proceeding...”) (“*Certain Condensers*”).

Although Apex requested the advisory opinion, the ALJ placed the burden of proof on the patent owner, ResMed, because the ALJ found the Supreme Court’s analysis and practical considerations provided in *Medtronic* applicable to this proceeding. IAO at 29. *Medtronic* concerned the burden of proof of infringement in a declaratory judgment action brought by a licensee. 134 S. Ct. at 845. In particular, the ALJ noted the Supreme Court’s statement that it is well settled “that the burden of proving infringement generally rests upon the patentee.” IAO at 29 (quoting *Medtronic*, 134 S. Ct. at 849). The ALJ also noted that the Supreme Court found that the operation of a declaratory judgment action is “procedural . . . leaving substantive rights unchanged.” *Id.* Because the Supreme Court found that the burden of proof is a substantive aspect of a claim, it held that the burden of proving infringement in a declaratory judgment action remains with the patent owner, “just as it would be had the patentee brought an infringement suit.” *Id.* Therefore, the ALJ found that ResMed, as the patent owner, has the burden of proof in this proceeding to show that Apex’s redesigned products infringe the asserted patents. *Id.* However, the ALJ stated that the outcome of this particular AOP is not dependent on which party carries the burden of proof. *Id.*

The IA states that the ALJ’s departure from Commission precedent is a matter of policy that should be reviewed. Petition of the Office of Unfair Import Investigations for Review of the

## PUBLIC VERSION

Initial Advisory Opinion (“IPet.”) at 8-9. The IA agrees with the ALJ that the assignment of burden in this proceeding is not outcome determinative. *Id.* at 9.

ResMed also asks the Commission to review this issue. ResMed asserts that *Medtronic* dealt with declaratory judgment actions, not advisory opinions. Complainants’ Petition for Review of the Initial Advisory Opinion (“RPet.”) at 4, n. 1. According to ResMed, the risk of inconsistent, equally controlling decisions that the court cautioned against in *Medtronic* is not applicable to AOPs where there is no final ruling on the merits. *Id.* (citing *Medtronic*, 134 S. Ct. at 849-50).

Apex asserts that *Medtronic* is controlling precedent that overrules the Commission’s prior decisions with respect to burden of proof. Respondents Apex Medical Corp. and Apex Medical USA Corp.’s Response to the Office of Unfair Import Investigations Petition for Review of the Initial Advisory Opinion (“ARespIA.”) at 9-10. Apex notes that the Supreme Court placed the burden of proof on the patent owner partly because the patent owner “is in a better position than an alleged infringer to know, and to be able to point out, just where, how, and why a product (or process) infringes a claim of that patent.” *Id.* at 9 (quoting *Medtronic*, 134 S. Ct. at 850). Apex claims that ResMed, as the patent owner, is in a better position than Apex to know, and to be able to point out, where, how, and why Apex’s redesigned products purportedly infringe ResMed’s patents. *Id.* at 9.

For the reasons explained below, the Commission has determined to reverse the ALJ’s decision to place the burden of proof on ResMed in this AOP. The Commission finds that the Supreme Court’s legal and practical considerations discussed in *Medtronic* weigh in favor of keeping the Commission’s longstanding practice of placing the burden of proof in AOPs on the

## PUBLIC VERSION

petitioner. In addition, unique aspects of the operation of the Commission's AOPs favor placing the burden of proof on the petitioner.

Contrary to Apex's contention, the Supreme Court's decision in *Medtronic* is not controlling precedent. *Medtronic* addressed whether a licensee had the burden of persuasion in a declaratory judgment action. It did not address proceedings under section 337. Rather, our longstanding practice is to place the burden of proof in AOPs on the petitioner. See, e.g., *Certain Reclosable Plastic Bags and Tubing*, Inv. No. 337-TA-266, IAO at 1 (May 25, 1989) (unreviewed); *Certain Condensers*, Inv. No. 337-TA-334, IAO at 2, 20; *Certain Integrated Circuit Telecommunications Chips*, Inv. No. 337-TA-337, Comm'n Op. at 21, n.14, USITC Pub. 2670, Doc ID 217024 (Aug. 1993). In *Telecommunications Chips*, the Commission noted that "[t]he Federal Circuit has upheld a Commission remedy which effectively shifted the burden of proof on infringement issues to require a company seeking to import goods to prove that its product does not infringe, despite the fact that, in general, the burden of proof is on the patentee to prove, by a preponderance of the evidence, that a given article does infringe the patent in question." Comm'n Op. at 21, n.14 (emphasis in original) (citing *Sealed Air Corp. v. Int'l Trade Comm'n*, 645 F.2d 976 (CCPA 1981)). The general exclusion order at issue in *Sealed Air* provided that "persons desiring to import multicellular plastic film into the United States may petition the Commission to institute such further proceedings as may be appropriate in order to determine whether the multicellular plastic film sought to be imported should be allowed entry into the United States." *Certain Multicellular Plastic Film*, Inv. No. 337-TA-54, Comm'n Determination, Order, and Op. at 4, USITC Pub. 987, Doc ID 235396 (June 1979).

The Supreme Court in *Medtronic* stated three legal propositions and three practical considerations in support of placing the burden of proving infringement on the patent owner in a

## PUBLIC VERSION

declaratory judgment action. The legal propositions were: (1) the burden of proving infringement generally rests upon the patentee; (2) the operation of the Declaratory Judgment Act is procedural; and (3) the burden of proving infringement of a patent is a substantive aspect of a claim. 134 S. Ct. at 849. With respect to the first practical consideration, the Court was concerned that shifting the burden of proof depending on which party brought the declaratory judgment action could create unnecessary postlitigation confusion regarding a patent's scope. *Id.* at 849-50. The Court explained if an alleged infringer brings a declaratory judgment action, and loses for failing to prove noninfringement, but then the patentee later brings an infringement action regarding the same patent and also loses by failing to prove infringement, both parties will be left without clear answers as to what methods and products are protected by the patent. *Id.* at 850. Second, the Court stated that the patentee is in a better position to understand its patents and explain how a process or product infringes. *Id.* Third, the Court found that the purpose of the Declaratory Judgment Act is to “ameliorate the dilemma posed by putting one who challenges a patent's scope to the choice between abandoning his rights or risking suit.” *Id.*

The Commission finds that the Supreme Court's legal and practical considerations in *Medtronic* weigh in favor of keeping the Commission's longstanding practice of placing the burden of proof in AOPs on the petitioner. While the operation of AOPs, under Commission Rule 210.79, is procedural, unlike a trial court's decision in a declaratory judgment action, the Federal Circuit ruled in 1988 that the Commission's advisory opinion in *Certain Amorphous Metals and Amorphous Metal Articles*, Inv. No. 337-TA-143, was not a final ruling on the merits, *i.e.*, it was not appealable.<sup>1</sup> *Allied Corp. v. Int'l Trade Comm'n*, 850 F.2d 1573, 1578

---

<sup>1</sup> The Commission notes that its advisory opinions apply only to the specific remedial order and products considered by the Commission in the advisory opinion proceeding and do not



## PUBLIC VERSION

(Fed. Cir. 1988). Further, the parties have provided no evidence of any risk that placing the burden of proof on the petitioner will create unnecessary postlitigation confusion regarding the scope of the patents at issue here.

Moreover, in AOPs, the patent owner is not necessarily in a better position to bear the burden of proof because the issues of patent scope and infringement of the original, accused products usually have already been determined in the underlying investigation. In such cases, the respondents are able to point out, how and why their redesign is different from the litigated products and does not infringe.

Additionally, the unique dilemma addressed by the Declaratory Judgment Act does not apply to AOPs because the Commission, in the underlying investigation, has either already issued a remedial order in which the complainant/patentee has proven infringement or a consent order in which the respondent has agreed to not import products that violate the consent order by infringing the asserted claims. The Commission has a strong interest, as do the parties, in providing rulings concerning the scope of remedial orders and consent orders. The Commission explained the competing interests of complainants and respondents in an advisory opinion in *In re Certain Surveying Devices*, Inv. No. 337-TA-68:

Although [remedial] orders are intended to protect a domestic industry from import-related unfair acts, they may also have the unintended side effect of inhibiting legitimate trade practices. Thus, both domestic and foreign companies may be deterred from embarking upon various business enterprises for fear that those enterprises may be proscribed by the Commission's remedial order. It is therefore incumbent on the Commission to dispel unnecessary business uncertainty by issuing advisory opinions upon the request of concerned parties.

To be weighed against the business-certainty interest of potential importers are the interests of the Commission and those of the domestic industry which the Commission has acted to defend. The Commission does not have the resources to

---

apply to any other issues. Commission advisory opinions are not meant to set Commission policy or precedent.

## PUBLIC VERSION

conduct a formal adjudication concerning every hypothetical question presented to it. And a complainant, which has gone through an investigation to obtain necessary relief, ought not to be continually called upon to defend the Commission's remedial order. Moreover, a complainant has a business-certainty interest, not unlike that of a potential importer, in the finality of the Commission's orders.

Advisory Op. at 2-3, Doc ID 217898, (Aug. 18, 1981). One could argue that the Commission's choice of placing the burden of proof on the petitioner might deter design arounds, thereby, inhibiting rather than fostering innovation and competition. On the other hand, it would be undesirable to incentivize respondents to repeatedly ask the Commission for advice regarding redesigned products that are not different from the originally litigated products.

Other unique aspects of the operation of the Commission's AOPs favor placing the burden of proof on the petitioner. For instance, the complainant may choose not to participate in an AOP requested by the respondent, and the burden of proof would have to be carried by the petitioner/respondent. *See Certain GPS Devices and Products Containing Same*, Inv. No. 337-TA-602, Advisory Op. at 1-2, Doc ID 423431 (Apr. 20, 2010) ("*GPS Devices*") (granting an advisory opinion that importation of downstream products containing chips that were not adjudicated by the Commission does not violate a limited exclusion order directed to downstream products, and noting that the complainants did not challenge the requester's assertion that importation of the products would not violate the exclusion order).<sup>2</sup> Moreover, regardless of whether the complainant participates in the AOP, Commission Rule 210.79 imposes several requirements on a respondent requesting an advisory opinion. First, a respondent seeking such

---

<sup>2</sup> The Commission understands that Customs and Border Protection ("CBP") employs the traditional two-step patent inquiry in its enforcement of Commission exclusion orders when determining whether imported articles are within the scope of an exclusion order. *See, e.g., Markman v. Westview Instruments, Inc.* 52 F.3d 967, 976 (Fed. Cir. 1995). The Commission's citation in *GPS Devices*, Advisory Op. at 4, to *Yingbin-Nature (Guangdong) Wood Indus. Co. v. U.S. Int'l Trade Comm'n*, 535 F.3d 1322 (Fed. Cir. 2008), was not intended to suggest that CBP should alter this two-step approach in enforcing Commission exclusion orders.

## PUBLIC VERSION

advice must demonstrate “a compelling business need for the advice” sought. 19 C.F.R. § 210.79. Second, the respondent must take care to frame its “request as fully and accurately as possible.” *Id.* Third, the respondent must show that “the issuance of such an advisory opinion would facilitate the enforcement of section 337 of the Tariff Act of 1930” and “would be in the public interest, and would benefit consumers and competitive conditions in the United States.” *Id.* Thus, it would be consistent for the petitioner to carry the entire burden in AOPs.

Finally, the Commission’s current practice of placing the burden of proof in AOPs on the petitioner is consistent with Congress’s preference that the burden be placed on petitioners when they seek post-order relief or clarification of an issued order. Under section 337(k)(2), any person who has previously been found by the Commission to be in violation may petition the Commission for a modification or rescission of an issued order. 19 U.S.C. 1337(k)(2); *see also* 19 C.F.R. § 210.76(a)(1). Section 337(k)(2)(A) explicitly provides that “the burden of proof in any proceeding before the Commission regarding such petition shall be on the petitioner.” 19 U.S.C. 1337(k)(2)(A); *see also* 19 C.F.R. § 210.76(a)(2). Given that redesigns may be adjudicated in a modification proceeding, if the burdens of proof in AOPs and modification proceedings were not the same, there could be different outcomes, depending on which proceeding respondents choose to initiate.

Accordingly, the Commission has determined to continue to place the burden of proof in AOPs on the party that requested the advice. Here, Apex requested an advisory opinion and, therefore, bears the burden of proving that its redesigned sleep-disordered breathing treatment systems and components are not covered by the Consent Order.

PUBLIC VERSION

IV. U.S. PATENT NO. 6,935,337

The '337 patent generally relates to a humidifier for delivering humidified air in a continuous positive airway pressure ("CPAP") system to patients with sleep-disordered breathing such as, for example, obstructive sleep apnea. IAO at 6-7. CPAP therapy keeps the breathing passage open by supplying a continuous stream of air to the patient's breathing passage. *Id.*

A CPAP system typically includes a blower for supplying breathable gas, a humidifier **30** for humidifying the breathable gas, and a patient interface such as a face mask. JX-1 at 1:16-30. As shown in the embodiment of FIGS. 6 and 7 (reproduced below), the humidifier **30** includes a top cover **36** having an inlet **32** and an outlet **34**, a gasket **38**, and a base **40**. *Id.* at 6:32-33. The top cover **36** with the gasket **38** covers and seals the humidifier **30**. *Id.* at 7:2-3. Air from the blower outlet passes into the humidifier inlet **32** where it is humidified and then passes out through an outlet **34** to a patient delivery conduit. *Id.* at 1:31-33.

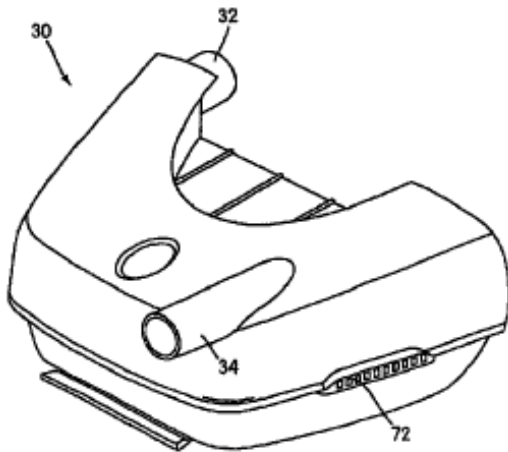

FIG. 6

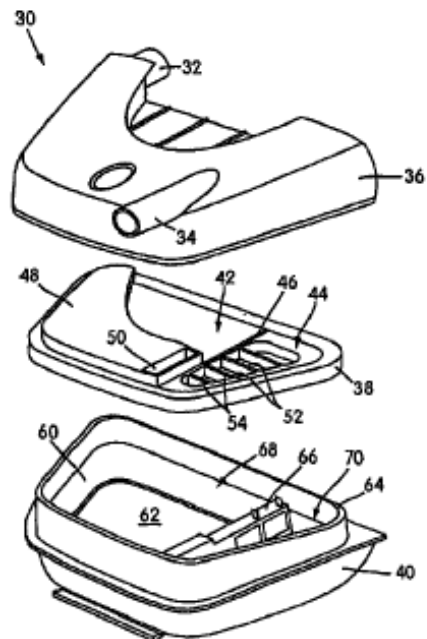

FIG. 7

## PUBLIC VERSION

Claim 20 of the '337 patent, the sole claim at issue, reads as follows:

An apparatus for humidifying breathable gas comprising:

at least one humidifier part to retain a body of liquid therein and to define at least one chamber therein;

an inlet in communication with an interior of the at least one humidifier part and connected to a blower outlet in use;

an outlet in communication with the interior of the at least one humidifier part and connected to a patient supply conduit in use;  
and

a top cover defining both the inlet and the outlet.

### A. Infringement

The sole dispute between the parties is whether Apex's redesigned iCH and XT humidifiers have a "top cover defining both the inlet and the outlet," as required by claim 20 of the '337 patent. IAO at 5. The ALJ agreed with the parties that the "top cover" limitation should be given its plain and ordinary meaning. *Id.* at 12.

#### i. iCH Humidifier

Apex's redesigned iCH humidifier includes three parts as shown below: a base piece, a divider piece including an outlet, and a topmost piece including an inlet. JPX-1.

Redesigned iCH Humidifier Tank

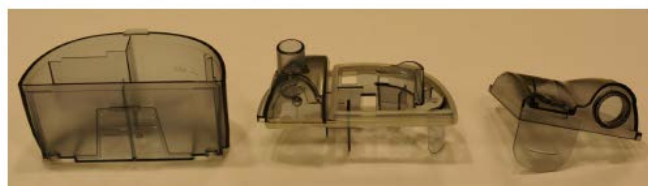

JPX-0001

CDX-2.105

**PUBLIC VERSION**

Based on the record evidence, the Commission has determined to adopt the ALJ’s finding that Apex’s redesigned iCH humidifier literally infringes claim 20 of the ’337 patent. IAO at 38-40. Apex relies solely on attorney argument in response to ResMed’s evidence showing that the topmost piece and the divider piece, when properly assembled on the humidifier tank, meet the claimed “top cover” limitation. *See* APet. at 34-38. We agree with the ALJ that Apex’s non-infringement arguments are irrelevant and unpersuasive. IAO at 33-37, 39. Accordingly, the Commission finds that Apex failed to meet its burden of proving noninfringement with respect to its redesigned iCH humidifier.

Because we conclude that the iCH humidifier literally infringes claim 20 of the ’337 patent, the Commission declines to reach the issue of infringement under the doctrine of equivalents. *See id.* at 40-51. Therefore, the Commission has determined to set aside this portion of the IAO.

**ii. XT Humidifier**

Apex’s redesigned XT humidifier includes three parts as shown below: a base plate, a tank body including an inlet, and a lid including an outlet. JPX-2.

**Redesigned XT Humidifier Tank**



JPX-0002

CDX-2.115

## PUBLIC VERSION

The ALJ found that the combination of the XT humidifier's tank body and lid is equivalent to the claimed "top cover" limitation. IAO at 55-58. Therefore, he determined that the XT humidifier infringes claim 20 under the doctrine of equivalents. *Id.* at 58.

Apex argues that the ALJ misapplied the law on doctrine of equivalents by not assessing the accused equivalent structure on a limitation-by-limitation basis, as required by the Supreme Court in *Warner-Jenkinson Co., Inc. v. Hilton Davis Chemical Co.*, 520 U.S. 17, 29 (1997), but instead erroneously assessed the accused device as a whole against the claimed apparatus as a whole. APet. at 13-14. In particular, Apex argues that the ALJ erroneously credited Dr. Webster's testimony regarding the function of the claimed "top cover" as "to have the pressurized gas go in and pass through and the pressurized gas come out the outlet, to pass to the patient mask as required for therapy." *Id.* at 14-15 (citing IAO at 56 (citing Tr. at 102-104)). Apex contends that this is not the function of the "top cover" limitation but, rather, is the function of the entire humidifier device. *Id.* at 15. Apex asserts that the functions of the "top cover" limitation are to cover the top of the humidifier and to define both the inlet and the outlet. *Id.* Apex argues that the inclusion of the tank body as part of the equivalent structure is absurd because it would require the tank body to cover itself. *Id.* at 16.

Apex also argues that under the holdings of *Engel Industries, Inc. v. Lockformer Co.*, 96 F.3d 1398, 1404-05 (Fed. Cir. 1996) and *Becton, Dickinson and Co. v. Tyco Healthcare Group, LP*, 616 F.3d 1249, 1254 (Fed. Cir. 2010), the iCH humidifier's tank body cannot satisfy two separately recited limitations, namely, both the "top cover" limitation and the "humidifier part to retain a body of liquid" limitation. APet. at 18. In *Engel*, the claim at issue provided for two separate elements: a "second portion" and a "return portion." 96 F.3d at 1404. The plaintiff asserted that the "second portion" includes the "return portion." *Id.* at 1404-05. Apex stated that

## PUBLIC VERSION

the court found that these two elements cannot be one and the same as it would contradict the plain language of the claim. APet. at 20. In *Becton*, the claim at issue was directed to a safety needle and required four elements: 1) a needle, 2) a guard that rides on the needle, 3) a hinged arm attached to the guard, and 4) a spring means connected to the hinged arm. 616 F.3d at 1254. The court held that “the clear implication of the claim language is that those elements are distinct components of the patented invention. *Id.* Apex argues that, similar to the claims at issue in *Engel* and *Becton*, nothing in the ’337 patent suggests that the tank body can be part of the claimed “top cover” and also the “at least one humidifier part to retain a body of liquid.” APet. at 20-21.

Apex and the IA argue that the ALJ’s application of the doctrine of equivalents to the XT humidifier entirely vitiated the explicit structural requirement that the top cover defines *both* the inlet and the outlet. *Id.* at 21; IPet. at 6-7. Relying on *Sage Products Inc. v. Devon Industries, Inc.*, 126 F.3d 1420, 1429-30 (Fed. Cir. 1997), Apex and the IA assert that the court applied vitiation as a limitation on the doctrine of equivalents. In *Sage Products*, the accused product was a container for disposal of hazardous waste and the asserted claim covered a disposal container with a slot at its top to allow waste into the container. *See* 126 F.3d at 1422-23. Apex argues that the court in *Sage Products* held that the doctrine of equivalents does not permit a patentee to remove entirely the “top of the container” and “over said slot” limitations from the asserted claim. APet. at 23. Similarly, Apex and the IA argue that the ALJ’s application of the doctrine of equivalents erased the clear structural and functional requirement that the top cover defines *both* the inlet and the outlet. *Id.* at 25; IPet. at 7. The IA argues that although the XT humidifier achieves a similar result, it does so in a different way, using structural arrangements



## PUBLIC VERSION

that are substantially different than the claimed invention. IPet. at 8 (citing Tr. (Leinsing) at 306-307).

ResMed responds that Apex's expert never opined that the equivalent structure of the XT humidifier does not perform the function Dr. Webster ascribed to it. Complainants' Response to Apex's and Staff's Petition for Review of the Initial Advisory Opinion ("RResp.") at 31. Rather, ResMed argues that Apex's expert opined that the equivalent structure performed an additional function, namely, assisting in retaining water within the humidifier structure. *Id.* (citing IAO at 56-57; Tr. at 306-07). ResMed also argues that Apex's case law does not stand for the proposition that the equivalent structure to the claimed "top cover" cannot also serve as an equivalent just because one part of that structure may also independently satisfy an additional claim limitation. *Id.* at 33. ResMed further argues that, because Apex urged the Commission to enter the Consent Order and because it withdrew the original humidifiers from the market, this AOP is akin to a district court contempt proceeding in which a district court determines whether there are "colorable differences" between an adjudged infringing product and a redesigned product. *Id.* at 35 (citing *TiVo Inc. v. EchoStar Corp.*, 646 F.3d 869, 882 (Fed. Cir. 2011) (en banc)). Therefore, ResMed contends that reviewing how Apex modified its products to arrive at its redesigns provides insight into how Apex understood the scope of the claims. *Id.* at 36. ResMed claims that Apex redesigned its humidifiers by "slic[ing] right through the top to make two pieces." *Id.* at 34 (citing Tr. at 104-06; CDX-2.120).

Based on the record evidence, the Commission finds that Apex has satisfied its burden of proving noninfringement with respect to the redesigned XT humidifier.<sup>3</sup> ResMed's theory of

---

<sup>3</sup> Even if the Commission adopts the ALJ's decision to place the burden of proof on ResMed, the outcome would be the same – Apex's redesigned XT humidifier is not covered by the Consent Order.

## PUBLIC VERSION

infringement under the doctrine of equivalents for the XT humidifier fails because the alleged equivalent structure does not substantially cover and seal the entire humidifier tank. The parties agree that the scope of the “top cover” limitation in claim 20 is limited in a way that plainly and necessarily excludes any structure that does not cover and seal the entire humidifier tank and defines both an inlet and an outlet. *See* IAO at 31, 34, 36; APet. at 30; Tr. (Webster) at 220 (“[T]he top cover in this case has to contain both the inlet and the outlet, and it certainly has to cover the base in order for it to work.”); *see also Bicon, Inc. v. Straumann Co.*, 441 F.3d 945, 950–51 (Fed. Cir. 2006) (“[C]laims are interpreted with an eye toward giving effect to all terms in the claim.”).

Under the ALJ’s analysis, only one inlet or outlet would need to be provided on the top cover, while the other can be provided anywhere on the humidifier assembly. There is no dispute that the lid of the redesigned XT humidifier provides the outlet. *See* IAO at 52. The ALJ improperly included the tank body with its inlet as part of the accused equivalent structure because the tank body does not perform the function of the claimed “top cover.” *See* APet. at 17; Tr. (Leinsing) at 306-307. We agree with Apex that such a finding directly contravenes the plain and ordinary meaning of the “top cover defining both the inlet and the outlet” limitation of claim 20 and leads to the illogical result that the top cover covers and seals itself or the base plate rather than the humidifier tank. For purposes of determining whether a patent is infringed under the doctrine of equivalents, “[e]quivalents are assessed on a limitation-by-limitation basis; this focus on individual limitations, rather than on the accused device as a whole, aids the court in being specially vigilant against allowing the concept of equivalence to eliminate any claim limitations completely.” *Allen Eng’g Corp. v. Bartell Indus., Inc.*, 299 F.3d 1336, 1345 (Fed. Cir. 2002) (citing *Warner-Jenkinson Co.*, 520 U.S. at 40). Accordingly, the Commission finds

## PUBLIC VERSION

that the alleged equivalent structure of the tank body and the lid cannot be brought within the scope of claim 20 through the doctrine of equivalents.

ResMed argues that the claimed and equivalent structures accomplish substantially the same function of the claimed “top cover” in substantially the same way, to achieve substantially the same result. ResMed’s expert, Dr. Webster, testified that the function of the claimed “top cover” is “to have the pressurized gas go in and pass through and the pressurized gas come out the outlet, to pass to the patient mask as required for therapy.” Tr. at 102-04. However, as Apex contends, this is the function of the entire XT humidifier, and not the function of the claimed “top cover.” APet. at 13-14. The doctrine of equivalents does not grant ResMed license to remove entirely the “top cover” limitation from the claim. *Sage Prods.*, 126 F.3d at 1424 (citing *Warner-Jenkinson*, 520 U.S. at 29 (“It is important to ensure that the application of the doctrine, even as to an individual element, is not allowed such broad play as to effectively eliminate that element in its entirety.”))).

One of the claims at issue in *Sage Products* recited a disposal container having a container body and “an elongated slot at the top of the container body for permitting access to the interior of the container body.” 126 F.3d at 1422. The court construed “top of the container body” according to its plain and ordinary meaning to mean the “highest point, level, or part of” *Id.* at 1422-23. The patentee’s theory of infringement under the doctrine of equivalents identified the space between two interior parts of the accused container as the elongated slot. *Id.* at 1423. The court found that the location of the “elongated slot” in the accused device was far enough within the container body that, as a matter of law, no finder of fact could find that it is located substantially at the “top of the container.” *Id.* at 1424. The court held that the doctrine of equivalents does not grant the patentee license to remove entirely the “top of the container”

## PUBLIC VERSION

limitation from the claim. *Id.* Similarly, we find application of the doctrine of equivalents here would write the “top cover” limitation out of claim 20 because the equivalent structure does not accomplish substantially the same function of the claimed “top cover,” which is to cover and seal the entire humidifier tank, in substantially the same way, to achieve substantially the same result. *See* APet. at 15; RResp. at 29 (citing Tr. at 101-103).

It is important to ensure that the application of the doctrine of equivalents to the “top cover” limitation is not allowed such broad play as to effectively eliminate that limitation in its entirety. *See Warner-Jenkinson Co.*, 520 U.S. at 29, 40. We find that the XT humidifier’s tank body and lid combination is not an insubstantial variation of the claimed “top cover” and cannot fall within the scope of claim 20 under the doctrine of equivalents without rendering the “top cover” requirement meaningless. *See* Tr. (Leinsing) 306-07; *Trading Techs. Intern., Inc. v. eSpeed, Inc.*, 595 F.3d 1340, 1356 (Fed. Cir. 2010) (holding that “Dual Dynamic’s automatic re-centering feature is substantially different from the claimed invention and cannot fall within the scope of the claims under the doctrine of equivalents without doing violence to the ‘static’ claim element”). Accordingly, the Commission has determined to reverse the ALJ’s finding that Apex’s redesigned XT humidifier infringes claim 20 of the ’337 patent under the doctrine of equivalents.

### **V. U.S. PATENT NO. 7,159,587**

The ’587 patent is a continuation of Application No. 10/377,110, which issued as U.S. Patent No. 6,823,865 (“the ’865 patent”). The ’865 patent is a continuation of Application No. 09/570,907, which issued as U.S. Patent No. 6,581,594 (“the ’594 patent”). The ’587 patent incorporates both parent applications by reference in their entirety. JX-2 at 1:9-13.

## PUBLIC VERSION

The patented technology generally relates to a nasal mask for use with a CPAP system. *Id.* at 3:7-8. The mask has a gas washout vent for venting exhaled gases to the atmosphere. *Id.* at 1:62-65. Exhausting gas through such vent openings creates noise. *Id.* at 1:66-2:2. The patent teaches that it is desirable for a mask and vent combination to maximize the elimination of exhaled gases and inhalation of the supplied breathable gas. *Id.* at 2:6-9. The patent also teaches that it is desirable to minimize the weight of the vent assembly for greater patient comfort, and design a vent that is easily cleaned or economically disposable. *Id.* at 2:14-15, 2:20-21.

The exemplary masks shown in FIGS. 1 and 2 below each include a gas washout vent constituted by an opening **26** in the shell **12** (FIG. 1) or gas inlet **20** (FIG. 2) across which extends a thin, air permeable membrane **28**. *Id.* at 4:41-43, 5:7-9. The patent teaches that the membrane **28** may be, for example, a stainless steel sheet (*Id.* at 4:44-45) or a hydrophobic material such as polytetrafluoroethylene (*Id.* at 3:16-20, 5:22-24, 5:51-55).

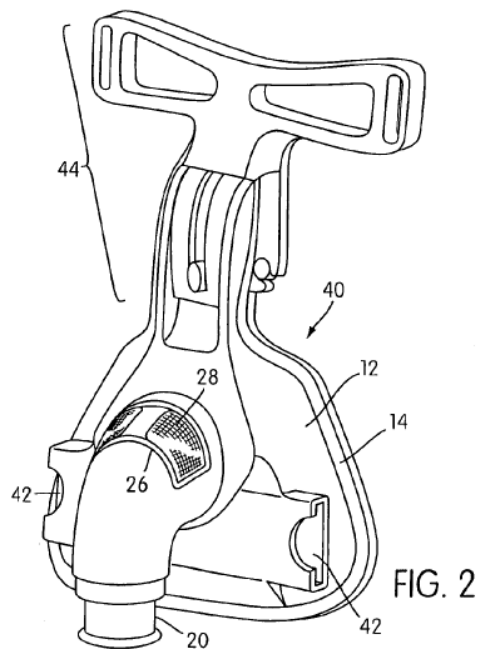
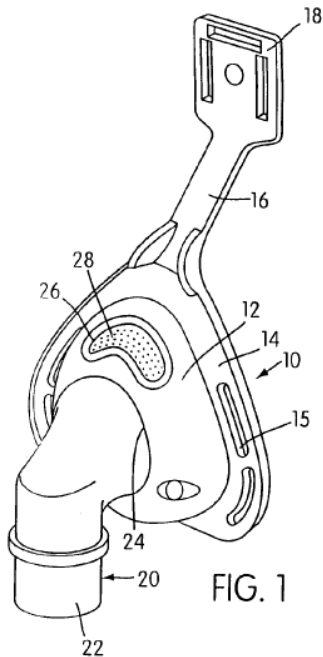

## PUBLIC VERSION

Claim 15 of the '587 patent, the sole claim at issue, reads as follows:

A respiratory mask comprising:

a patient interface;

a breathable gas inlet to provide pressurized gas to a breathing cavity formed at least in part by the patient interface when the mask is in use; and

a gas washout vent portion having a plurality of holes extending therethrough, each said hole having a diameter selected to allow gas to quietly exit from the breathing cavity, wherein:

the vent portion has a thickness of less than about 3 mm, and

the vent portion is made of a hydrophobic material.

### A. Claim Construction

The parties disputed whether the “gas washout vent portion” limitation of claim 15 was limited to vents having “a thin air permeable membrane extending across an opening for exhausting gas to the atmosphere.” IAO at 12-22. While Apex and the IA argued that claim 15 should be limited to vents having thin air permeable membranes, ResMed contended that the “gas washout vent portion” requires no construction and should be given its plain and ordinary meaning. *Id.*

The ALJ resolved the dispute in favor of Apex and the IA. IAO at 22. The ALJ found that the intrinsic evidence consistently and exclusively refers to the invention as including a thin air permeable membrane and the intrinsic record evinces a clear intention to limit the vent in the '587 patent. *Id.* at 22-24.

ResMed argues that the limitation “a gas washout vent portion” should be given its plain and ordinary meaning, which the parties agree is “a vent for exhausting gas to the atmosphere.” *Id.* at 13. ResMed argues that the ALJ’s construction of “gas washout vent portion” violates the rule that the plain meaning must apply unless the patentee explicitly defines the term, or clearly

## PUBLIC VERSION

and unmistakably disavows the plain meaning. RPet. at 7-8. ResMed contends that the ALJ improperly disregarded alternative embodiments and other patent claims that demonstrate “gas washout vent” is not limited to thin air permeable membranes. *Id.* at 12-13 (citing JX-2 at Abstract, 6:36-42; Tr. (Webster) at 149-150). According to ResMed, the novelty of the ’587 patent is not tied to the use of thin air permeable membranes but, rather, is based on specific characteristics of the vent related to, for example, the thickness, number, arrangement and shape of vent holes. *Id.* at 9. Furthermore, ResMed asserts that one inventor of the ’587 patent, Dr. Drew, understood the patent to include gas washout vents having no thin air permeable membrane such as holes drilled through the mask frame. *Id.* at 9-10 (citing CX-83 at 20-21, 39-40). ResMed also asserts that the file history of the ’587 patent does not clearly and unmistakably disavow the plain meaning. *Id.* at 16. On the contrary, ResMed argues that the examiner relied on prior art that was not constructed of a membrane to read on the limitation “a gas washout vent portion.” *Id.* (citing JX-5 at 67). ResMed further argues that the presiding ALJ’s decision conflicts with another ALJ’s construction of the same term in a related child patent (Markman Order, Inv. No. 337-TA-890; CX-45-40) to mean “a vent for exhausting air to the atmosphere,” and conflicts with the use of the term in the parent and grandparent patents where “a gas washout vent” was expressly limited to a “thin air permeable membrane.” RPet. at 16-17 (citing JX-7 at 7:12-13, 7:38-39; JX-8 at 7:26-27, 8:66-67).

Apex responds that the invention is only described as including a thin air permeable membrane, all of the embodiments within the specification of the ’587 patent support this description and construction and the primary inventor of the ’587 patent, Dr. Drew, acknowledged that every single embodiment of the ’587 patent required a thin air permeable membrane. Respondents Apex Medical Corp. and Apex Medical USA Corp.’s Opposition to

## PUBLIC VERSION

Complainants ResMed Corp., ResMed Inc., and ResMed Ltd's Petition for Review of Initial Advisory Opinion ("ARespr.") at 1. Apex asserts that ResMed's proposed construction is inconsistent with the holding of *Phillips v. AWH Corp.*, 415 F.3d 1303, 1315 (Fed. Cir. 2005), which requires that the claims be interpreted in light of the specification. *Id.* at 1-2. According to Apex, the stainless steel configuration described in the specification is an embodiment of the thin permeable membrane, not an alternative embodiment that does not include a membrane. *Id.* at 10. Apex argues that ResMed's arguments with respect to claims 29, 33, and 34 are untimely and prejudicial. *Id.* at 13. Apex contends that the prosecution history is of little value because the examiner uses the broadest reasonable meaning of the claim term in examining an application. *Id.* at 15. Finally, Apex argues that other patents in the '587 patent family do not support ResMed's proposed construction because ResMed has not set forth a claim differentiation argument with respect to the '587 patent. *Id.* at 18, 20.

The IA responds that the ALJ's construction is mandated by the express language of the '587 patent. Combined Response of the Office of Unfair Import Investigations to the Private Parties' Petitions for Review of the Initial Advisory Opinion ("IResp.") at 8-9 (citing JX-2 at 3:7-9, 3:52-56, 3:57-63, 6:29-30). The IA contends that the '587 patent is directed to the use of a thin air permeable membrane as an alternative to conventional vent configurations. *Id.* (citing JX-2 at 3:7-62). The IA argues that ResMed does not identify any statement in the intrinsic record that is inconsistent with the requirement of a thin air permeable membrane. *Id.* at 9-10. The IA asserts that both parties' experts and an inventor agree that every embodiment disclosed in the '587 patent requires a thin air permeable membrane. *Id.* at 9 (citing CX-83C at 34:11-24, 40:21-41:14; Tr. (Webster) at 145:6-11; Tr. (Leinsing) at 263:10-23, 266:10-13, 264:14-265:6).



## PUBLIC VERSION

According to the IA, Figure 8 of the '587 patent shows an example embodiment of the mask claimed in claim 34. *Id.* at 9 (citing JX-2 at Fig. 8, 6:16-21).

Based on the intrinsic evidence, the Commission has determined to adopt the ALJ's construction of the "gas washout vent portion" limitation to mean "a vent comprising a thin air permeable membrane extending across an opening for exhausting gas to the atmosphere." We clarify that this construction is based on specification disavowal as evidenced by the patentee's repeated disparaging of prior art masks having vents made of the same material and thickness as the mask shell, and the patentee's clear and unmistakable statements that limit the scope of the claims to masks having vents constituting a thin air permeable membrane. *See SciMed Life Sys. Inc. v. Advanced Cardiovascular Sys., Inc.*, 242 F.3d 1337, 1341 (Fed. Cir. 2001) ("Where the specification makes clear that the invention does not include a particular feature, that feature is deemed to be outside the reach of the claims of the patent, even though the language of the claims, read without reference to the specification, might be considered broad enough to encompass the feature in question.").

We find that the specification makes clear that the invention does not include masks having vents made of the same material and thickness as the mask shell. The patentee stated that it is important to minimize the noise and the weight of the gas washout vent for greater patient comfort. JX-2 at 1:66-2:15. The patentee stated that "[i]t is also desirable that a vent be easily cleaned or economically disposable." *Id.* at 2:20-21. The background of the specification describes a variety of gas washout vent configurations. *Id.* at 2:22-67. For example, the patentee stated that it was known that openings can be provided in the mask shell to allow the flow of exhaust gas from the inner cavity to the atmosphere. *Id.* at 2:22-25. The specification's discussion of the prior art recognizes that vent assemblies existed in which the "ports defining

## PUBLIC VERSION

the vent have the same cross-sectional thickness and are formed from the same polycarbonate material that is used to form the swivel elbow and the mask shell frame.” *Id.* at 2:32-34. The ’587 patent teaches away from prior art vents that are thicker than 3 mm and/or “formed from the same [] material” as the mask. *See id; see also id.* at 2:39-40 (in describing another prior art manufactured by Respironics, Inc, the patent states the “piece is made of the same material and thickness as is used to make the mask shell.”); 2:44-49 (describing a vent formed from a porous sintered material of approximately 3-4 mm thickness).

Instead, the patentee states that “the present invention” provides a vent having a thin air permeable membrane as an alternative to conventional vent configurations. *Id.* at 3:1-3 (“It is an object of the present invention to provide an alternative form of vent that is suitable for use in a respiratory mask.”); 3:7-9 (“The *present invention* provides a vent assembly suitable for use with a vent mask used in CPAP treatment *wherein the vent assembly is a thin air permeable membrane.*”) (emphasis added); *see also id.* at 3:10-62. When the specification “describes the features of the ‘present invention’ as a whole, this description limits the scope of the invention.” *Verizon Serv. Corp. v. Vonage Holdings Corp.*, 503 F. 3d 1295, 1308 (Fed. Cir. 2007); *see, e.g., Honeywell Int’l, Inc. v. ITT Indus., Inc.*, 452 F.3d 1312, 1318 (Fed. Cir. 2006) (limiting claim term to one embodiment described because specification repeatedly referred to the embodiment as “this invention” or “the present invention” and noting that “[t]he public is entitled to take the patentee at his word).

Other parts of the patent specification repeatedly and consistently state that the invention includes a thin air permeable membrane, and nothing in the intrinsic record suggests otherwise. In addition to the summary of the invention, JX-2 at 3:7-62, the patent specification describes every embodiment and figure to include a thin air permeable membrane.

## PUBLIC VERSION

- With respect to the Figure 1 embodiment, the specification states: “The mask **10** includes a gas washout vent constituted by an opening **26** in the shell **12** across which extends a thin air permeable membrane **28**. In the FIG. 1 embodiment, the thin air permeable membrane **28** is a stainless steel sheet . . .” *Id.* at 4:41-45.
- With respect to the Figure 2 embodiment, the specification states: “The mask **40** also includes a vent constituted by an opening **26** formed in the gas inlet **20** across which extends a thin air permeable membrane **28**.” *Id.* at 5:7-9.
- With respect to the Figure 3 embodiment, the specification states: “The mask **60** includes an opening **26** across which is extended a thin air permeable membrane **28** of identical construction to the PTFE membrane discussed below in relation to the mask **40** shown in FIG. 6.” *Id.* at 5:21-25.
- With respect to the Figure 4 embodiment, the specification states: “FIG. 4 shows a cross-section of vent assembly **110**. There is provided a membrane **114** interposed between an outer element **112** and an inner element **116**.” *Id.* at 5:25-27.
- With respect to the Figure 5 embodiment: “FIG. 5 shows an alternative cross-section of a vent assembly **110**. There is provided a stainless steel membrane insert **118** positioned over the inner element **120**.” *Id.* at 5:35-39.
- With respect to the Figure 6 embodiment: “the mask **80** includes two cylindrical inserts **82** which have an inner opening **26** across which extends the thin air permeable material **28**.” *Id.* at 5:49-51.
- With respect to the Figure 7 embodiment, the specification states: “The mask **100** is similar to the mask **80** shown in FIG. 6 in that the vent is provided in the inserts **82**.” *Id.* at 6:11-13.
- With respect to the Figure 8 embodiment, the specification states: Figure 8 “is a close-up view of the insert shown in FIG. 6, the insert **82** is comprises a cylindrical portion **86** sized to be a snug fit into a circular orifice **88** provided in the mask shell **12**.” *Id.* at 6:15-19.
- With respect to the Figure 9 embodiment the specification states: “In this embodiment, the in-line vent assembly comprises a generally cylindrical shaped vent frame with ‘windows’ or ‘ports’ covered with a membrane as described above.” *Id.* at 6:25-28.

## PUBLIC VERSION

The patentee's consistent reference to a thin air permeable membrane evinces a clear intention to limit the invention to a mask having a thin air permeable membrane. *See id*; *Absolute Software, Inc. v. Stealth Signal, Inc.* 659 F. 3d 1121, 1136 (Fed. Cir. 2011) (“[A] patentee’s consistent reference to a certain limitation or a preferred embodiment as ‘this invention’ or the ‘present invention’ can serve to limit the scope of the entire invention, particularly where no other intrinsic evidence suggests otherwise.”); *Edwards Lifesciences LLC v. Cook Inc.*, 582 F.3d 1322, 1330 (Fed. Cir. 2009) (where the specification frequently describes the “present invention” or “this invention” as an “intraluminal graft,” the patentee has indicated an intent to limit the invention to intraluminal devices).

ResMed does not identify any statement in the intrinsic record that is inconsistent with the requirement of a thin air permeable membrane. ResMed argues that the Abstract states “[i]n *one embodiment*, the vent is made of a thin air permeable membrane,” and therefore, there are other possible embodiments of gas washout vent portions that do not require a membrane. RPet. at 12 (emphasis original). ResMed argues that such an alternative embodiment includes a vent constructed from stainless steel. *Id.* On the contrary, the patent specification states that a stainless steel sheet is merely an embodiment of a thin air permeable membrane. *See* JX-2 at 4:44-47 (“In the FIG. 1 embodiment, the thin air permeable membrane **28** is a stainless steel sheet . . .”). In fact, a vent constructed from stainless steel is referred to as a “membrane” throughout the specification. *Id.*; *see also* JX-2 at 3:25-26 (“the membrane is constructed from stainless steel”); 5:35-37 (“FIG. 5 shows an alternative cross-section of a vent assembly **110**. There is provided a stainless steel membrane insert **118** positioned over the inner element **120**.”). Thus, although the specification states that the material of the membrane may vary, it also explains that the requirement of a thin air permeable membrane remains the same. We find that

## PUBLIC VERSION

ResMed's attempts to read the Abstract and particular statements in isolation are not persuasive evidence that the specification describes embodiments that do not include a membrane.

ResMed argues that construing the phrase "a gas washout vent portion" as requiring a thin air permeable membrane is contrary to the language of claims 29, 33, and 34 of the '587 patent. RPet. at 15. We disagree. Claim 34 recites "a gas washout vent portion provided on the frame and having a plurality of holes extending through the frame portion." JX-2 at 10:15-17. Claims 29 and 33 recite "a gas washout vent . . . that extend through the frame portion." At the outset, we note that the ALJ did not construe the meaning of "extend through" as these claims are not asserted. ARespR. at 14. ResMed also belatedly made arguments with respect to claims 29 and 33 for the first time in its post-hearing brief. *Id.* at 13-14, 13 n.1. The ALJ noted that the patent discloses embodiments that appear to be covered by these claims. IAO at 26 (citing JX-2 at FIG. 6, 5:49-51); *see also* JX-2 at FIGS. 7 and 8, 6:16-21. We agree with the ALJ that these embodiments show that the use of a plurality of holes through the mask frame and the use of a membrane as a gas washout vent are not mutually exclusive. *Id.*

ResMed also argues that the examiner relied on prior art that was not constructed of a membrane to read on the limitation "a gas washout vent portion." RPet. at 16 (citing JX-5 at 67). We agree with the ALJ that the prosecution history does not blur the clear disavowal in the specification. IAO at 26.

ResMed further argues that the ALJ's decision conflicts with the use of the same term in the parent '865 and '594 patents where "a gas washout vent" was expressly limited to a "thin air permeable membrane." RPet. at 16-17 (citing JX-7 at 7:12-13, 7:38-39; JX-8 at 7:26-27, 8:66-67). ResMed's petition cited multiple Federal Circuit cases for the proposition that the prosecution history of parent patents may be considered intrinsic evidence in construing claims.

## PUBLIC VERSION

*See id.* at 18 (citing *Masco Corp. v. United States*, 303 F.3d 1316, 1324 (Fed. Cir. 2002)). Even if we consider the claims of these parent patents to be intrinsic evidence, the claims alone do not support ResMed's argument because the applicant made no statements in the prosecution histories about the scope of the claimed invention. Further, there is no legal authority for applying the doctrine of claim differentiation to claims in different patents. ARespR. at 21-22.

While we find no reason to look beyond the intrinsic evidence in construing the disputed limitation, we find that the extrinsic evidence supports the ALJ's construction. Both ResMed's expert, Dr. Webster, and Apex's expert, Mr. Leinsing agree the patent only describes embodiments using thin air permeable membranes as gas washout vents. *See* Tr. (Webster) at 145:6-11; Tr. (Leinsing) at 263:10-23, 266:10-13, 264:14-265:6. One of the inventors, Dr. Drew, also agrees that the patent only describes embodiments using thin air permeable membranes as gas washout vents. *See* CX-83C at 34:11-24, 40:21-41:14. Finally, contrary to ResMed's assertion, the presiding ALJ's construction is not inconsistent with another ALJ's construction of the same term in a related child patent asserted in Inv. No. 337-TA-890. CX-45-40. In any case, the Markman Order in the 890 investigation is an interlocutory order that has not been subject to a Commission determination. Moreover, Apex is not a party in the 890 investigation, and the construction in the 890 investigation was based on claim differentiation principles and different record evidence, which are not applicable here. APet. at 22.

In view of the above, the Commission has determined to adopt the ALJ's construction of the "a gas washout vent portion" limitation to require "a vent comprising a thin air permeable membrane extending across an opening for exhausting gas to the atmosphere."

## PUBLIC VERSION

### **B. Infringement**

ResMed's petition relates solely to the ALJ's construction of the "a gas washout vent portion" limitation. RPet. at 7-20. ResMed concedes that Apex's redesigned WiZARD 220 mask does not infringe claim 15 of the '587 patent if the Commission adopts the ALJ's construction. IAO at 58. Because we find that the ALJ correctly construed "a gas washout vent portion," the Commission has determined to adopt the ALJ's finding that the WiZARD 220 mask does not meet this limitation. *See id.*

Claim 15 also requires that the "gas washout vent portion" have "holes extending therethrough . . ." and that the vent containing those holes be "less than about 3 mm" thick. The ALJ found that the limitation should be interpreted according to its plain and ordinary meaning. *Id.* at 28. The ALJ also found that the redesigned mask has a vent portion with "a thickness of less than about 3 mm." *Id.* In light of our finding that the redesigned mask does not have a thin air permeable membrane as required by the claimed "gas washout vent portion," we determine that Apex's redesigned mask also does not have a vent portion with "a thickness of less than about 3 mm." Accordingly, the Commission has determined to reverse the ALJ's finding that the redesigned mask's vent contains holes "less than about 3 mm" thick.

### **VI. CONCLUSION**

In view of the above, the Commission has determined to reverse the ALJ's decision to place the burden of proof in this proceeding on the patent owner, ResMed. In addition, the Commission has determined to adopt, with modified reasoning, the ALJ's findings that Apex's redesigned iCH humidifier is covered by the Consent Order, and Apex's redesigned WiZARD 220 mask is not covered by the Consent Order. The Commission has also determined to reverse the ALJ's finding that Apex's redesigned XT humidifier is covered by the Consent Order.

**PUBLIC VERSION**

By order of the Commission.

A handwritten signature in black ink, appearing to read 'Lisa R. Barton', written in a cursive style.

Lisa R. Barton  
Secretary to the Commission

Issued: August 11, 2014