

Certain Mobile Access Equipment and Subassemblies Thereof from China

Investigation Nos. 701-TA-665 and 731-TA-1557 (Preliminary)

Publication 5186

April 2021

U.S. International Trade Commission

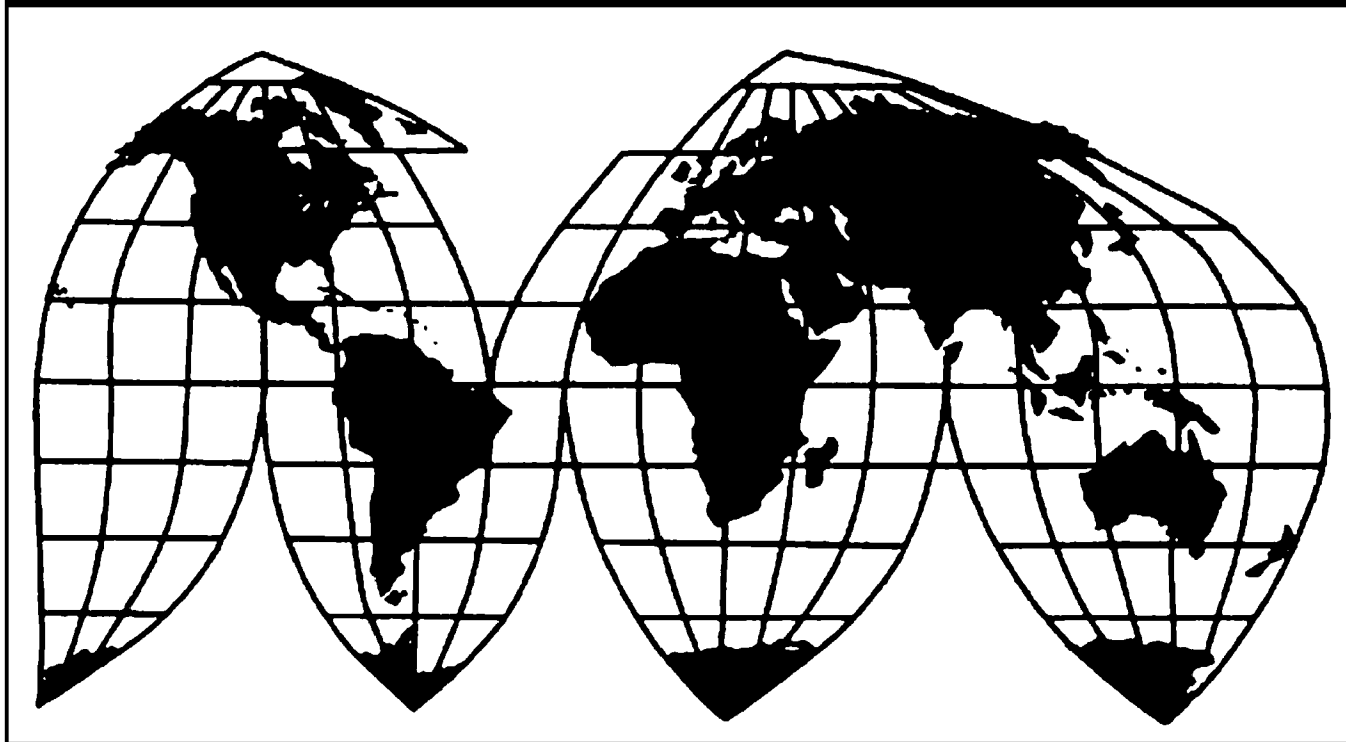

Washington, DC 20436

U.S. International Trade Commission

COMMISSIONERS

Jason E. Kearns, Chair
Randolph J. Stayin, Vice Chair
David S. Johanson
Rhonda K. Schmidlein
Amy A. Karpel

Catherine DeFilippo
Director of Operations

Staff assigned

Alejandro Orozco, Investigator
Kristina Lara, Investigator
Brennan Taylor, Industry Analyst
Natalia King, Economist
Emily Kim, Accountant
Lita David-Harris, Statistician
David Goldfine, Attorney
Mary Beth Jones, Supervisory Investigator

Address all communications to
Secretary to the Commission
United States International Trade Commission
Washington, DC 20436

U.S. International Trade Commission

Washington, DC 20436
www.usitc.gov

Certain Mobile Access Equipment and Subassemblies Thereof from China

Investigation Nos. 701-TA-665 and 731-TA-1557 (Preliminary)

Publication 5186



April 2021

CONTENTS

	Page
Determinations	1
Views of the Commission.....	3
Separate and Concurring Views of Commissioner David S. Johanson	37
Part I: Introduction	I-1
Background.....	I-1
Statutory criteria	I-2
Organization of report.....	I-3
Market summary	I-3
Summary data and data sources.....	I-4
Previous and related investigations.....	I-5
Nature and extent of alleged subsidies and sales at LTFV	I-5
Alleged subsidies	I-5
Alleged sales at LTFV	I-7
The subject merchandise	I-8
Commerce’s scope	I-8
Tariff treatment.....	I-10
Section 301 tariff treatment.....	I-11
The product.....	I-11
Description and applications.....	I-11
Manufacturing processes	I-18
Domestic like product issues.....	I-19
Part II: Conditions of competition in the U.S. market.....	II-1
U.S. market characteristics.....	II-1
ANSI standards	II-3
Secondary refurbished MAE market	II-4
Section 301 tariffs.....	II-5
Channels of distribution	II-5
Geographic distribution	II-6

CONTENTS

	Page
Part II: Conditions of competition in the U.S. market--Continued	
Supply and demand considerations.....	II-7
U.S. supply	II-7
U.S. demand	II-9
Substitutability issues.....	II-12
Lead times	II-12
Factors affecting purchasing decisions.....	II-13
Comparison of U.S.-produced and imported MAE	II-13
Part III: U.S. producers' production, shipments, and employment	III-1
U.S. producers	III-1
Impact of the COVID-19 pandemic.....	III-5
U.S. production, capacity, and capacity utilization	III-7
Alternative products.....	III-10
Foreign trade zone.....	III-10
U.S. producers' U.S. shipments and exports.....	III-11
U.S. producers' inventories.....	III-13
U.S. producers' imports.....	III-14
U.S. producers' purchases.....	III-21
U.S. employment, wages, and productivity	III-21
Part IV: U.S. imports, apparent U.S. consumption, and market shares	IV-1
U.S. importers.....	IV-1
U.S. imports.....	IV-4
Negligibility.....	IV-7
Apparent U.S. consumption	IV-8
Complete MAE: U.S. imports and U.S. producers' U.S. shipments	IV-11
MAE subassemblies: U.S. imports and U.S. producers' U.S. shipments	IV-14
U.S. shipments of subassemblies, by end use.....	IV-17

CONTENTS

	Page
Part V: Pricing data	V-1
Factors affecting prices	V-1
Raw material costs	V-1
Transportation costs to the U.S. market.....	V-3
U.S. inland transportation costs.....	V-3
Pricing practices	V-3
Pricing methods.....	V-3
Sales terms and discounts	V-5
Price data.....	V-6
Price trends.....	V-16
Price comparisons	V-18
Lost sales and lost revenue	V-18
Part VI: Financial experience of U.S. producers	VI-1
Background.....	VI-1
Operations on MAE.....	VI-1
Net Sales	VI-8
Cost of goods sold and gross profit or loss.....	VI-9
SG&A expenses and operating income or loss.....	VI-12
Interest expense, other expenses and income, and net income or loss.....	VI-12
Capital expenditures and research and development expenses.....	VI-14
Assets and return on assets	VI-15
Capital and investment	VI-16

CONTENTS

	Page
Part VII: Threat considerations and information on nonsubject countries.....	VII-1
The industry in China.....	VII-3
Changes in operations.....	VII-5
Operations on MAE.....	VII-6
Alternative products.....	VII-8
Exports.....	VII-9
U.S. inventories of imported merchandise.....	VII-10
U.S. importers' outstanding orders.....	VII-11
Antidumping or countervailing duty orders in third-country markets.....	VII-11
Information on nonsubject countries.....	VII-12

CONTENTS

Page

Appendixes

A. <i>Federal Register</i> notices	A-1
B. List of staff conference witnesses	B-1
C. Summary data	C-1
D. Semi-finished product analysis.....	D-1
E. Average unit value analysis	E-1
F. U.S. importers' imports of MAE subassemblies, by type	F-1

Note: Information that would reveal confidential operations of individual concerns may not be published. Such information is identified by brackets in confidential reports and is deleted and replaced with asterisks (***) in public reports.

UNITED STATES INTERNATIONAL TRADE COMMISSION

Investigation Nos. 701-TA-665 and 731-TA-1557 (Preliminary)

Certain Mobile Access Equipment and Subassemblies Thereof from China

DETERMINATIONS

On the basis of the record¹ developed in the subject investigations, the United States International Trade Commission (“Commission”) determines, pursuant to the Tariff Act of 1930 (“the Act”), that there is a reasonable indication that an industry in the United States is materially injured by reason of imports of certain mobile access equipment and subassemblies thereof (“mobile access equipment”) from China, provided for in subheadings 8427.10.80, 8427.20.80, 8427.90.00, and 8431.20.00 of the Harmonized Tariff Schedule of the United States, that are alleged to be sold in the United States at less than fair value (“LTFV”) and to be subsidized by the government of China.²

COMMENCEMENT OF FINAL PHASE INVESTIGATIONS

Pursuant to section 207.18 of the Commission’s rules, the Commission also gives notice of the commencement of the final phase of its investigations. The Commission will issue a final phase notice of scheduling, which will be published in the *Federal Register* as provided in § 207.21 of the Commission’s rules, upon notice from the U.S. Department of Commerce (“Commerce”) of affirmative preliminary determinations in the investigations under §§ 703(b) or 733(b) of the Act, or, if the preliminary determinations are negative, upon notice of affirmative final determinations in those investigations under §§ 705(a) or 735(a) of the Act. Parties that filed entries of appearance in the preliminary phase of the investigations need not enter a separate appearance for the final phase of the investigations. Industrial users, and, if the merchandise under investigation is sold at the retail level, representative consumer organizations have the right to appear as parties in Commission antidumping and countervailing duty investigations. The Secretary will prepare a public service list containing the names and addresses of all persons, or their representatives, who are parties to the investigations.

¹ The record is defined in § 207.2(f) of the Commission’s Rules of Practice and Procedure (19 CFR 207.2(f)).

² 86 FR 15905 and 86 FR 15922 (March 25, 2021).

BACKGROUND

On February 26, 2021, the Coalition of American Manufacturers of Mobile Access Equipment (“CAMMAE” or “the Coalition”)³ filed petitions with the Commission and Commerce, alleging that an industry in the United States is materially injured and threatened with material injury by reason of subsidized and LTFV imports of certain mobile access equipment from China. Accordingly, effective February 26, 2021, the Commission instituted countervailing duty investigation No. 701-TA-665 and antidumping duty investigation No. 731-TA-1557 (Preliminary).

Notice of the institution of the Commission’s investigations and of a public conference to be held in connection therewith was given by posting copies of the notice in the Office of the Secretary, U.S. International Trade Commission, Washington, DC, and by publishing the notice in the *Federal Register* of March 4, 2021 (86 FR 12711). In light of the restrictions on access to the Commission building due to the COVID–19 pandemic, the Commission conducted its conference through written testimony and video conference on March 19, 2021. All persons who requested the opportunity were permitted to participate.

³ The Coalition is composed of JLG Industries, Inc. (“JLG”), Hagerstown, Maryland and Terex Corporation (“Terex”), Redmond, Washington.

Views of the Commission

Based on the record in the preliminary phase of these investigations, we determine that there is a reasonable indication that an industry in the United States is materially injured by reason of imports of certain mobile access equipment and subassemblies thereof (“mobile access equipment” or “MAE”) from China that are allegedly sold in the United States at less than fair value and that are allegedly subsidized by the government of China.¹

I. The Legal Standard for Preliminary Determinations

The legal standard for preliminary antidumping and countervailing duty determinations requires the Commission to determine, based upon the information available at the time of the preliminary determinations, whether there is a reasonable indication that a domestic industry is materially injured or threatened with material injury, or that the establishment of an industry is materially retarded, by reason of the allegedly unfairly traded imports.² In applying this standard, the Commission weighs the evidence before it and determines whether “(1) the record as a whole contains clear and convincing evidence that there is no material injury or threat of such injury; and (2) no likelihood exists that contrary evidence will arise in a final investigation.”³

II. Background

The Coalition of American Manufacturers of Mobile Access Equipment (“the Coalition” or “Petitioner”), a trade association whose two member firms⁴ are U.S. producers of MAE, filed the petitions in these investigations on February 26, 2021. Representatives for Petitioner submitted testimony and appeared at the staff conference accompanied by counsel. Petitioner also submitted a postconference brief.

¹ Commissioner David S. Johanson concurs, finding that there is a reasonable indication that an industry in the United States is threatened with material injury by reason of the subject imports. See Separate and Concurring Views of Commissioner David. S. Johanson.

² 19 U.S.C. §§ 1671b(a), 1673b(a) (2000); see also *American Lamb Co. v. United States*, 785 F.2d 994, 1001-04 (Fed. Cir. 1986); *Aristech Chem. Corp. v. United States*, 20 CIT 353, 354-55 (1996). No party argues that the establishment of an industry in the United States is materially retarded by the allegedly unfairly traded imports.

³ *American Lamb Co.*, 785 F.2d at 1001; see also *Texas Crushed Stone Co. v. United States*, 35 F.3d 1535, 1543 (Fed. Cir. 1994).

⁴ The Coalition is comprised of JLG Industries, Inc. (“JLG”) and Terex Corporation (“Terex”).

The following respondents submitted testimony, appeared at the hearing accompanied by counsel, and submitted a joint postconference brief: Zhejiang Dingli Machinery Co., Ltd., Hunan Sinoboom Intelligent Equipment Co., Ltd., Mantall Heavy Industry Co., Ltd., Lingong Group Jinan Heavy Machinery Co., Ltd., LGMG North America Inc., and the China Chamber of Commerce for Import and Export of Machinery and Electronic Products Subcommittee of Mobile Access Equipment Exporters, which are producers/exporters of MAE from China (collectively, “Chinese Respondents”). The California Manufacturing and Engineering Company (“MEC”), a domestic producer of MAE and an importer of subject merchandise from China, submitted testimony, appeared at the staff conference accompanied by counsel, and submitted a postconference brief.

U.S. industry data are based on the questionnaire responses of seven firms accounting for the vast majority of U.S. production of MAE in 2020.⁵ U.S. import data are based on the questionnaire responses from 15 U.S. importers, accounting for approximately *** percent⁶ of subject imports from China in 2020 under Harmonized Tariff Schedule subheadings 8427.10, 8427.20, 8427.90, and 8431.20.⁷ Foreign industry data and related information are based on the questionnaire responses of six producers/exporters of MAE in China accounting for approximately *** percent of MAE production in China in 2020 and approximately *** percent of U.S. imports of subject merchandise from China in 2020.⁸

III. Domestic Like Product

In determining whether there is a reasonable indication that an industry in the United States is materially injured or threatened with material injury by reason of imports of the subject merchandise, the Commission first defines the “domestic like product” and the “industry.”⁹ Section 771(4)(A) of the Tariff Act of 1930, as amended (“the Tariff Act”), defines the relevant domestic industry as the “producers as a whole of a domestic like product, or those producers whose collective output of a domestic like product constitutes a major

⁵ Confidential Report (“CR”) at I-4, INV-TT-052 (Apr. 5, 2020); Public Report, *Certain Mobile Access Equipment and Subassemblies Thereof from China*, Inv. Nos. 701-TA-665 and 731-TA-1557 (Preliminary), USITC Pub. 5186 (April 2021) (“PR”) at I-4.

⁶ Subject imports’ coverage is based on finished units of MAE, which were estimated to be a total of *** units in 2020. CR/PR at IV-1 n.3.

⁷ CR/PR at I-4 & IV-1-2. HTS subheadings 8427.10, 8427.20, 8427.90, and 8431.20 are “basket” categories that may contain out-of-scope merchandise. CR/PR at IV-2.

⁸ CR/PR at VII-3.

⁹ 19 U.S.C. § 1677(4)(A).

proportion of the total domestic production of the product.”¹⁰ In turn, the Tariff Act defines “domestic like product” as “a product which is like, or in the absence of like, most similar in characteristics and uses with, the article subject to an investigation.”¹¹

By statute, the Commission’s “domestic like product” analysis begins with the “article subject to an investigation,” *i.e.*, the subject merchandise as determined by the U.S. Department of Commerce (“Commerce”).¹² Therefore, Commerce’s determination as to the scope of the imported merchandise that is subsidized and/or sold at less than fair value is “necessarily the starting point of the Commission’s like product analysis.”¹³ The Commission then defines the domestic like product in light of the imported articles Commerce has identified.¹⁴ The decision regarding the appropriate domestic like product(s) in an investigation is a factual determination, and the Commission has applied the statutory standard of “like” or “most similar in characteristics and uses” on a case-by-case basis.¹⁵ No single factor is dispositive, and the Commission may consider other factors it deems relevant based on the

¹⁰ 19 U.S.C. § 1677(4)(A).

¹¹ 19 U.S.C. § 1677(10).

¹² 19 U.S.C. § 1677(10). The Commission must accept Commerce’s determination as to the scope of the imported merchandise that is subsidized and/or sold at less than fair value. *See, e.g., USEC, Inc. v. United States*, 34 Fed. App’x 725, 730 (Fed. Cir. 2002) (“The ITC may not modify the class or kind of imported merchandise examined by Commerce.”); *Algoma Steel Corp. v. United States*, 688 F. Supp. 639, 644 (Ct. Int’l Trade 1988), *aff’d*, 865 F.3d 240 (Fed. Cir.), *cert. denied*, 492 U.S. 919 (1989).

¹³ *Cleo Inc. v. United States*, 501 F.3d 1291, 1298 (Fed. Cir. 2007); *see also Hitachi Metals, Ltd. v. United States*, Case No. 19-1289, slip op. at 8-9 (Fed. Cir. Feb. 7, 2020) (the statute requires the Commission to start with Commerce’s subject merchandise in reaching its own like product determination).

¹⁴ *Cleo*, 501 F.3d at 1298 n.1 (“Commerce’s {scope} finding does not control the Commission’s {like product} determination.”); *Hosiden Corp. v. Advanced Display Mfrs.*, 85 F.3d 1561, 1568 (Fed. Cir. 1996) (the Commission may find a single like product corresponding to several different classes or kinds defined by Commerce); *Torrington Co. v. United States*, 747 F. Supp. 744, 748-52 (Ct. Int’l Trade 1990), *aff’d*, 938 F.2d 1278 (Fed. Cir. 1991) (affirming the Commission’s determination defining six like products in investigations where Commerce found five classes or kinds).

¹⁵ *See, e.g., Cleo Inc. v. United States*, 501 F.3d 1291, 1299 (Fed. Cir. 2007); *NEC Corp. v. Department of Commerce*, 36 F. Supp. 2d 380, 383 (Ct. Int’l Trade 1998); *Nippon Steel Corp. v. United States*, 19 CIT 450, 455 (1995); *Torrington Co. v. United States*, 747 F. Supp. 744, 749 n.3 (Ct. Int’l Trade 1990), *aff’d*, 938 F.2d 1278 (Fed. Cir. 1991) (“every like product determination ‘must be made on the particular record at issue’ and the ‘unique facts of each case’”). The Commission generally considers a number of factors including the following: (1) physical characteristics and uses; (2) interchangeability; (3) channels of distribution; (4) customer and producer perceptions of the products; (5) common manufacturing facilities, production processes, and production employees; and, where appropriate, (6) price. *See Nippon*, 19 CIT at 455 n.4; *Timken Co. v. United States*, 913 F. Supp. 580, 584 (Ct. Int’l Trade 1996).

facts of a particular investigation.¹⁶ The Commission looks for clear dividing lines among possible like products and disregards minor variations.¹⁷ The Commission may, where appropriate, include domestic articles in the domestic like product in addition to those described in the scope.¹⁸

A. Scope Definition

In its notices of initiation, Commerce defined the imported merchandise within the scope of these investigations as:

. . . certain mobile access equipment, which consists primarily of boom lifts, scissor lifts, and material telehandlers, and subassemblies thereof. Mobile access equipment combines a mobile (self-propelled or towed) chassis, with a lifting device (e.g., scissor arms, boom assemblies) for mechanically lifting persons, tools and/ or materials capable of reaching a working height of ten feet or more, and a coupler that provides an attachment point for the lifting device, in addition to other components. The scope of this investigation covers mobile access equipment and subassemblies thereof whether finished or unfinished, whether assembled or unassembled, and whether the equipment contains any additional features that provide for functions beyond the primary lifting function.

Subject merchandise includes, but is not limited to, the following subassemblies:

- *Scissor arm assemblies, or scissor arm sections, for connection to chassis and platform assemblies. These assemblies include: (1) Pin assemblies that connect sections to form scissor arm assemblies, and (2) actuators that power the arm assemblies to extend and retract. These assemblies may or may not also include blocks that allow sliding of end sections in relation to frame and platform, hydraulic hoses, electrical cables, and/or other components;*

¹⁶ See, e.g., S. Rep. No. 96-249 at 90-91 (1979).

¹⁷ See, e.g., *Nippon*, 19 CIT at 455; *Torrington*, 747 F. Supp. at 748-49; see also S. Rep. No. 96-249 at 90-91 (Congress has indicated that the like product standard should not be interpreted in “such a narrow fashion as to permit minor differences in physical characteristics or uses to lead to the conclusion that the product and article are not ‘like’ each other, nor should the definition of ‘like product’ be interpreted in such a fashion as to prevent consideration of an industry adversely affected by the imports under consideration.”).

¹⁸ See, e.g., *Pure Magnesium from China and Israel*, Inv. Nos. 701-TA-403 and 731-TA-895-96 (Final), USITC Pub. 3467 at 8 n.34 (Nov. 2001); *Torrington*, 747 F. Supp. at 748-49 (holding that the Commission is not legally required to limit the domestic like product to the product advocated by the petitioner, co-extensive with the scope).

- *boom assemblies, or boom sections, for connection to the boom turntable, or to the chassis assembly, or to a platform assembly or to a lifting device. Boom assemblies include telescoping sections where the smallest section (or tube) can be nested in the next larger section (or tube) and can slide out for extension and/or articulated sections joined by pins. These assemblies may or may not include pins, hydraulic cylinders, hydraulic hoses, electrical cables, and/or other components;*
- *chassis assemblies, for connection to scissor arm assemblies, or to boom assemblies, or to boom turntable assemblies. Chassis assemblies include: (1) Chassis frames, and (2) frame sections. Chassis assemblies may or may not include axles, wheel end components, steering cylinders, engine assembly, transmission, drive shafts, tires and wheels, crawler tracks and wheels, fuel tank, hydraulic oil tanks, battery assemblies, and/or other components;*
- *boom turntable assemblies, for connection to chassis assemblies, or to boom assemblies. Boom turntable assemblies include turntable frames. Boom turntable assemblies may or may not include engine assembly, slewing rings, fuel tank, hydraulic oil tank, battery assemblies, counterweights, hoods (enclosures), and/or other components.*

Importation of any of these subassemblies, whether assembled or unassembled, constitutes unfinished mobile access equipment for purposes of this investigation.

Processing of finished and unfinished mobile access equipment and subassemblies such as trimming, cutting, grinding, notching, punching, slitting, drilling, welding, joining, bolting, bending, beveling, riveting, minor fabrication, galvanizing, painting, coating, finishing, assembly, or any other processing either in the country of manufacture of the in-scope product or in a third country does not remove the product from the scope. Inclusion of other components not identified as comprising the finished or unfinished mobile access equipment does not remove the product from the scope.

The scope excludes forklifts, vertical mast lifts, mobile self-propelled cranes and motor vehicles that incorporate a scissor arm assembly or boom assembly. Forklifts are material handling vehicles with a working attachment, usually a fork, lifted along a vertical guide rail with the operator seated or standing on the chassis behind the vertical mast. Vertical mast lifts are person and material lifting vehicles with a working attachment, usually a platform, lifted along a vertical guide rail with an operator standing on the platform. Mobile self-propelled cranes are material handling vehicles with a boom attachment for lifting loads of tools or materials that are suspended on ropes, cables, and/or chains, and which contain winches mounted on or near the

base of the boom with ropes, cables, and/or chains managed along the boom structure. The scope also excludes motor vehicles (defined as a vehicle driven or drawn by mechanical power and manufactured primarily for use on public streets, roads, and highways, but does not include a vehicle operated only on a rail line pursuant to 49 U.S.C. 30102(a)(7)) that incorporate a scissor arm assembly or boom assembly. The scope further excludes vehicles driven or drawn by mechanical power operated only on a rail line that incorporate a scissor arm assembly or boom assembly. The scope also excludes: (1) Rail line vehicles, defined as vehicles with hi-rail gear or track wheels, and a fixed (nontelescopic) main boom, which perform operations on rail lines, such as laying rails, setting ties, or other rail maintenance jobs; and (2) certain rail line vehicle subassemblies, defined as chassis subassemblies and boom turntable subassemblies for rail line vehicles with a fixed (non-telescopic) main boom.¹⁹

MAE is machinery that combines a self-propelled mobile chassis with a direct lifting device for the purpose of lifting people, tools, or materials.²⁰ MAE covered by the scope of these investigations have a minimum working height of ten feet and include MAE subassemblies (unassembled or unfinished MAE).²¹ The scope excludes forklifts, mobile self-propelled cranes, and motor vehicles that incorporate scissor arm attachments or boom attachments.²²

Although there are a range of products that are classified as MAE, there are three main product categories: (1) scissor lifts, (2) boom lifts, and (3) telehandlers.²³ Scissor lifts are hydraulic platforms that are designed to raise vertically.²⁴ Boom lifts are aerial work platforms that consist of a base with a hydraulic lift system attached that powers a crane as well as a platform or “bucket” that is primarily used to lift a single worker.²⁵ Telehandlers, or telescopic handlers, are MAE that resemble forklifts but perform operations at greater heights and higher

¹⁹ *Certain Mobile Access Equipment and Subassemblies Thereof from the People’s Republic of China: Initiation of Less-Than-Fair-Value Investigation*, 86 Fed. Reg. 15922, 15927-15928 (Mar. 25, 2021); *Certain Mobile Access Equipment and Subassemblies Thereof from the People’s Republic of China: Initiation of Countervailing Duty Investigation*, 86 Fed. Reg. 15905, 15907-15908 (Mar. 25, 2021).

²⁰ MAE can also be referred to as aerial lifts, aerial work platforms (AWP), and/or mobile elevating work platforms (MEWP). CR/PR at I-11.

²¹ CR/PR at I-11.

²² CR/PR at I-11.

²³ CR/PR at I-13.

²⁴ CR/PR at I-13.

²⁵ CR/PR at I-14.

weight capacities.²⁶ Within and among these three major categories of MAE, there is wide variation in terms of size, features, and lifting capabilities.²⁷

B. Arguments of the Parties

Petitioner's Arguments. Petitioner argues that the Commission should define a single domestic like product consisting of all MAE, coextensive with Commerce's scope in these preliminary phase investigations.²⁸ Petitioner maintains that the three major product categories of domestically produced MAE are all part of single domestic like product.²⁹ Based upon the traditional six factors, Petitioner contends that all domestically produced MAE within the scope have similar physical characteristics and uses, channels of distribution, common manufacturing facilities, production processes, and employees, customer and producer perceptions, are generally interchangeable, and are sold within a reasonable range of similar prices.³⁰

Employing the Commission's semi-finished analysis for domestic like product, Petitioner contends that in-scope domestically produced MAE subassemblies are not a separate domestic like product from in-scope domestically produced finished MAE.³¹ According to Petitioner, MAE subassemblies are dedicated exclusively to the production of finished MAE products, there is no separate market for MAE subassemblies, and MAE subassemblies generally share the same physical characteristics as in-scope finished MAE products.³² Petitioner also maintains that MAE subassemblies account for the vast majority of the total cost of goods sold ("COGS") for finished MAE and that the processes used to transform MAE subassemblies into finished MAE products are relatively minor.³³

Respondents' Arguments. Chinese Respondents argue that it is "doubtful" that the three major categories of MAE within the scope constitute a single domestic like product under the Commission's like product analysis, due to differences among scissor lifts, boom lifts, and telehandlers.³⁴ Nevertheless, Chinese Respondents expressly do not object to Petitioner's

²⁶ Telehandlers are mostly used for rough terrain in construction and agricultural environments and are often equipped with four-wheel drive as well as a boom attached to a chassis that can lift materials 50 feet with capacities weighing more than 5,500 pounds. CR/PR at I-15.

²⁷ CR/PR at I-12-16.

²⁸ Petitioner's Postconf. Br. at 5 & Exh. 1 at 27-32.

²⁹ Petitioner's Postconf. Br. at 5 & Exh. 1 at 27-32.

³⁰ Petitioner's Postconf. Br., Exh. 1 at 27-33.

³¹ Petitioner's Postconf. Br., Exh. 1 at 33-37.

³² Petitioner's Postconf. Br., Exh. 1 at 34-36.

³³ Petitioner's Postconf. Br., Exh. 1 at 34, 36-37.

³⁴ Chinese Respondents' Postconf. Br. at 5-6.

proposed domestic like product definition for purposes of these preliminary phase investigations.³⁵ Instead, they reserve the right to challenge Petitioner’s proposed domestic like product definition in any final phase investigations.³⁶ MEC did not address the issue of domestic like product.

C. Analysis

1. MAE Generally

Based on the record in these preliminary investigations, we define a single domestic like product consisting of all domestically produced MAE coextensive within the scope. As discussed below, we cannot conclude on the record in these preliminary phase investigations that there are clear dividing lines distinguishing in-scope articles, and no parties have argued for separate domestic like products corresponding to articles within the scope for purposes of these preliminary determinations.

Physical Characteristics and Uses. All domestically produced MAE within the scope are mobile structures made primarily of fabricated steel.³⁷ While there are some variations in size, design, and lifting capacity among scissor lifts, boom lifts, and telehandlers, all domestically produced MAE within the scope shares certain common physical characteristics, including a chassis base with an attached lifting assembly.³⁸ According to Petitioner, all domestically produced MAE within the scope is used to lift personnel, tools, and other cargo to various heights usually in construction applications, although Chinese Respondents maintain that telehandlers are used to lift cargo while scissor lifts and boom lifts are used to lift people.³⁹

Manufacturing Facilities, Production Processes, and Employees. All domestically produced MAE within the scope is manufactured using the same general production process, which includes four major steps: (1) fabrication, (2) wet and dry paint application, (3) sub-assembly and (4) final assembly.⁴⁰ Both petitioning firms, JLG and Terex, report that they produce all MAE within the scope (including scissor lifts, boom lifts, and telehandlers) in the same facilities, using the same production processes and the same employees.⁴¹

³⁵ Chinese Respondents’ Postconf. Br. at 5-6; Conf. Tr. at 178-179 (Kahn).

³⁶ Chinese Respondents’ Postconf. Br. at 6.

³⁷ CR/PR at I-16; Petitioner’s Postconf. Br., Answers to Staff Questions, Exh. 1 at 27.

³⁸ CR/PR at I-11; Petitioner’s Postconf. Br., Answers to Staff Questions, Exh. 1 at 27.

³⁹ Petition at 20; Petitioner’s Postconf. Br., Answers to Staff Questions, Exh. 1 at 28; Chinese Respondents’ Postconf. Br. at 5.

⁴⁰ CR/PR at I-15-16; Petitioner’s Postconf. Br., Answers to Staff Questions, Exh. 1 at 30.

⁴¹ Petitioner’s Postconf. Br., Answers to Staff Questions, Exh. 1 at 29-31. As described by Petitioner, “***he production process is also the same for all MAE. The large steel components are (Continued...)

Channels of Distribution. During the January 2018-December 2020 period of investigation (“POI”),⁴² domestically produced MAE of all types was sold mainly to end-users (ranging from *** percent to *** percent during the POI) with the remainder sold to distributors (ranging from *** percent to *** percent).⁴³ The record does not indicate any differences in the channels of distribution for the major product categories of MAE.

Interchangeability. The record on this factor is limited. While recognizing that U.S. producers supply MAE tailored to their various customers’ specific end uses, Petitioner also claims that all domestically produced MAE within the scope is generally interchangeable.⁴⁴

Producer and Customer Perceptions. The record contains very limited information concerning this factor. According to Petitioner, customers and producers perceive all domestically produced MAE within the scope as comprising a single product category.⁴⁵

Price. The limited pricing data on the record indicate broad differences in price ranges among the four domestically produced MAE pricing products representing different types of MAE.⁴⁶

Conclusion. Evidence on the record of these preliminary phase investigations indicates that all domestically produced MAE within the scope is made primarily of the same raw material (*i.e.*, steel and fabricated steel parts). Although there are differences in size, design, and lifting capacity among scissor lifts, boom lifts, and telehandlers, all domestically produced MAE constitute mobile structures and share certain other physical characteristics, including a chassis base with an attached lifting assembly. All domestically produced MAE within the scope generally is produced through the same general production process, used primarily to lift cargo

(...Continued)

fabricated by ‘manually or robotically welding {} sheet plate steel’ and are then painted. These components are attached to create subassemblies, including chassis subassemblies, scissor subassemblies, and boom subassemblies. These subassemblies are then attached to one another to create the finished MAE; specifically, a scissor or boom subassembly is attached to a chassis subassembly.” *Id.* at 30 (internal citations omitted).

⁴¹ CR/PR at Tables C-1 & C-2.

⁴² CR/PR at Tables C-1 & C-2.

⁴³ CR/PR at Table II-1.

⁴⁴ Petitioner’s Postconf. Br., Answers to Staff Questions, Exh. 1 at 28; Petition at 20. At the conference, a witness appearing on behalf of Petitioner testified that all types of in-scope domestically produced MAE with similar lifting capabilities is interchangeable for the same use. Conf. Tr. at 85 (Morris) (“{I}f you need to lift 500 pounds to 19 feet, you could accomplish that with a scissor lift, you could accomplish that with a boom lift, you can even accomplish that with a telehandler.”).

⁴⁵ Petitioner’s Postconf. Br., Answers to Staff Questions, Exh. 1 at 30-31; Conf. Tr. at 85, 88 (Morris).

⁴⁶ CR/PR at Tables V-3-6.

and/or workers on construction sites, and sold overwhelmingly through the same channels of distribution to end-users. Although there is limited interchangeability and a range of prices for different types of in-scope domestically produced MAE, in light of all of the factors we cannot conclude on the basis of the record in these preliminary investigations that differences in the type of MAE constitute a clear dividing line such that we should define each as a separate domestic like product. In light of the above, and the lack of any contrary argument at this preliminary phase, we define a single domestic like product consisting of all domestically produced MAE, coextensive with the scope.

2. MAE Subassemblies

We now turn to the semifinished products analysis to consider whether the upstream product – MAE subassemblies – and the downstream product – finished MAE – are part of a single domestic like product.⁴⁷ As discussed above, the scope of these investigations includes both MAE subassemblies and finished MAE.

Dedication for Use. Six of seven responding U.S. producers and 11 of 12 responding U.S. importers reported that MAE subassemblies are dedicated entirely or almost entirely to the production of finished MAE.⁴⁸

Separate Markets. Five of seven responding domestic producers and 9 of 12 responding U.S. importers reported that there is no separate market for MAE subassemblies that is distinct from the market for finished MAE.⁴⁹

Differences in Physical Characteristics and Functions of the Upstream and Downstream Articles. According to the Petitioner, there are virtually no differences in physical characteristics and functions between MAE subassemblies and finished MAE, particularly since they are both made from steel products and MAE subassemblies are used to form finished

⁴⁷ In a semi-finished products analysis, the Commission examines the following: (1) the significance and extent of the processes used to transform the upstream into the downstream articles; (2) whether the upstream article is dedicated to the production of the downstream article or has independent uses; (3) differences in the physical characteristics and functions of the upstream and downstream articles; (4) whether there are perceived to be separate markets for the upstream and downstream articles; and (5) differences in the costs or value of the vertically differentiated articles. See, e.g., *Glycine from India, Japan, and Korea*, Inv. Nos. 731-TA-1111-1113 (Preliminary), USITC Pub. No. 3921 at 7 (May 2007); *Artists' Canvas from China*, Inv. No. 731-TA-1091 (Final), USITC Pub. No. 3853 at 6 (May 2006); *Live Swine from Canada*, Inv. No. 731-TA-1076 (Final), USITC Pub. 3766 at 8 n.40 (Apr. 2005); *Certain Frozen Fish Fillets from Vietnam*, Inv. No. 731-TA-1012 (Preliminary), USITC Pub. No. 3533 at 7 (Aug. 2002).

⁴⁸ CR/PR at Table I-4 & Appendix D.

⁴⁹ CR/PR at Table I-4 & Appendix D.

MAE.⁵⁰ Four of seven responding U.S. producers and 7 of 12 responding U.S. importers reported no differences in physical characteristics and functions between MAE subassemblies and finished MAE.⁵¹

Differences in the Costs or Value. According to the Petitioner, MAE subassemblies comprise approximately 90 to 95 percent of the cost of finished MAE.⁵² The majority of responding U.S. producers reported that there was a significant difference in the cost or value between MAE subassemblies and finished MAE.⁵³ By contrast, the majority of responding U.S. importers (7 of 12) reported no significant difference in the cost or value between MAE subassemblies and finished MAE.⁵⁴

Significance and Extent of Processes Used to Transform Upstream Product into Downstream Product. Petitioner contends that the process for transforming MAE subassemblies into finished MAE is relatively minor in nature claiming that it largely involves connecting subassemblies to one another to form finished MAE.⁵⁵ The majority of responding U.S. producers (4 of 7) described the processes used to transform MAE subassemblies into finished MAE as labor or capital intensive.⁵⁶ By contrast, the majority of responding U.S. importers (6 of 11) described the process as not being labor or capital intensive.⁵⁷

Conclusion. In our view, the evidence on the record of these preliminary phase investigations supports finding that MAE subassemblies are not a separate domestic like product. The majority of U.S. producers and importers reported that MAE subassemblies are used to produce finished MAE, that there is no separate market for MAE subassemblies, and that there are no differences in physical characteristics and functions between MAE subassemblies and finished MAE. On the other hand, the responses of producers and importers were mixed concerning differences in cost or value between MAE subassemblies and finished MAE, and the extent of processes used to transform MAE subassemblies into finished MAE. In light of the information available in the current record and the absence of any contrary argument, we include both finished MAE and MAE subassemblies in the same domestic like product.

⁵⁰ Petitioner's Postconf. Br., Answers to Staff Questions, Exh. 1 at 35.

⁵¹ CR/PR at Table I-4 & Appendix D.

⁵² Petitioner's Postconf. Br., Answers to Staff Questions, Exh. 1 at 36-37.

⁵³ CR/PR at Table I-4 & Appendix D.

⁵⁴ CR/PR at Table I-4 & Appendix D.

⁵⁵ Petitioner's Postconf. Br., Answers to Staff Questions, Exh. 1 at 34.

⁵⁶ CR/PR at Table I-4 & Appendix D.

⁵⁷ CR/PR at Table I-4 & Appendix D.

Accordingly, we define a single domestic like product consisting of all domestically produced MAE, coextensive with the scope of the investigations, for purposes of the preliminary phase of the investigations.

IV. Domestic Industry and Related Parties

The domestic industry is defined as the domestic “producers as a whole of a domestic like product, or those producers whose collective output of a domestic like product constitutes a major proportion of the total domestic production of the product.”⁵⁸ In defining the domestic industry, the Commission’s general practice has been to include in the industry producers of all domestic production of the like product, whether toll-produced, captively consumed, or sold in the domestic merchant market.

We consider whether any producer of the domestic like product should be excluded from the domestic industry pursuant to Section 771(4)(B) of the Tariff Act. This provision allows the Commission, if appropriate circumstances exist, to exclude from the domestic industry producers that are related to an exporter or importer of subject merchandise or which are themselves importers.⁵⁹ Exclusion of such a producer is within the Commission’s discretion based upon the facts presented in each investigation.⁶⁰

The record indicates that six domestic producers are subject to the related parties provision since they each imported subject merchandise during the POI: Haulotte North America Manufacturing, LLC (“Haulotte”), JLG, MEC, Snorkel International LLC (“Snorkel”),

⁵⁸ 19 U.S.C. § 1677(4)(A).

⁵⁹ See *Torrington Co. v. United States*, 790 F. Supp. 1161, 1168 (Ct. Int’l Trade 1992), *aff’d mem.*, 991 F.2d 809 (Fed. Cir. 1993); *Sandvik AB v. United States*, 721 F. Supp. 1322, 1331-32 (Ct. Int’l Trade 1989), *aff’d mem.*, 904 F.2d 46 (Fed. Cir. 1990); *Empire Plow Co. v. United States*, 675 F. Supp. 1348, 1352 (Ct. Int’l Trade 1987).

⁶⁰ 19 U.S.C. § 1677(4)(B). The primary factors the Commission has examined in deciding whether appropriate circumstances exist to exclude a related party include the following:

- (1) the percentage of domestic production attributable to the importing producer;
- (2) the reason the U.S. producer has decided to import the product subject to investigation (whether the firm benefits from the LTFV sales or subsidies or whether the firm must import in order to enable it to continue production and compete in the U.S. market);
- (3) whether inclusion or exclusion of the related party will skew the data for the rest of the industry;
- (4) the ratio of import shipments to U.S. production for the imported product; and
- (5) whether the primary interest of the importing producer lies in domestic production or importation. *Changzhou Trina Solar Energy Co. v. USITC*, 100 F. Supp.3d 1314, 1326-31 (Ct. Int’l. Trade 2015); see also *Torrington Co. v. United States*, 790 F. Supp. at 1168.

Terex, and Xtreme Manufacturing (“Xtreme”).⁶¹ Most of these firms are also potentially related parties by virtue of their corporate relationships, including their affiliations with producers and exporters of subject merchandise from China and U.S. importers of subject merchandise.⁶²

A. Arguments of the Parties

Petitioner’s Arguments. Petitioner argues that appropriate circumstances exist to exclude domestic producer MEC from the domestic industry, but did not address whether appropriate circumstances exist to exclude any other domestic producers pursuant to the related parties provision. Emphasizing that MEC was almost exclusively an importer of subject merchandise throughout the POI and unfairly benefitted from its affiliation with a subject producer of MAE in China, Petitioner urges the Commission to find that appropriate circumstances exist to exclude MEC from the domestic industry.⁶³ Accordingly, Petitioner argues that the Commission should define the domestic industry as all domestic producers of MAE, but exclude MEC as a related party.⁶⁴

⁶¹ CR/PR at Tables III-8 to III-14.

⁶² CR/PR at Table III-2. *** is affiliated with ***, which was a U.S. importer of subject merchandise during the POI. *** is affiliated with and imported from a subject producer in China, *** during the POI. CR/PR at Table III-2; *** U.S. Importer Questionnaire at II-5a.

*** is affiliated with ***, a subject producer in China that exported subject merchandise to the U.S. market during the POI. CR/PR at Table III-2; *** Foreign Producer Questionnaire at II-8.

*** is 25-percent owned by Zhejiang Dingli Machinery Co. Ltd. (“Zhejiang”), a subject producer in China that exported subject merchandise to the U.S. market during the POI. CR/PR at Table III-2; MEC Postconf. Br. at 4.

As discussed below, *** is 51-percent owned by domestic producer ***, which also imported subject merchandise from China during the POI. CR/PR at Tables III-2 & III-13. Although *** is also affiliated with a subject producer in China, CR/PR at Table III-2, there is no information in the current record indicating that *** affiliate in China exported subject merchandise to the U.S. market during the POI.

*** is affiliated with ***, a subject producer in China that exported subject merchandise to the U.S. market during the POI. CR/PR at Table III-2; *** Foreign Producer Questionnaire at II-8.

*** owns 51-percent of *** and both *** and *** imported subject merchandise during the POI. CR/PR at Tables III-2, III-11, III-13, and III-14. Although *** is affiliated with *** affiliate in China, CR/PR at Table III-2, there is no information in the current record indicating that the affiliate exported subject merchandise to the U.S. market during the POI.

⁶³ Petitioner’s Postconf. Br. at 6-7.

⁶⁴ Petitioner’s Postconf. Br. at 5-6.

Respondents' Arguments. Chinese Respondents do not object to Petitioner's proposed definition of the domestic industry for purposes of these preliminary determinations, but reserve the right to revisit the issue in any final phase investigations.⁶⁵

MEC did not specifically address the issue of domestic industry definition or related parties at the conference or in its postconference brief. Nonetheless, MEC appears to suggest that its principal interest was in domestic production rather than importation during the POI.⁶⁶ While acknowledging that subject producer Dingli has a 25-percent ownership interest in MEC, MEC contends that Dingli does not have operational, strategic, or price control over MEC's domestic MAE production.⁶⁷ MEC asserts that it imported subject merchandise during the POI only when it was unable to meet demand from inventory or to round out its product offerings.⁶⁸

B. Analysis

We discuss below for each of the related party producers whether appropriate circumstances exist to exclude it from the domestic industry based on the firms' importing activities.

***.⁶⁹ *** the petitions.⁷⁰ *** imports of subject merchandise were *** units in 2018, *** units in 2019, and *** units in 2020.⁷¹ *** indicated that ***.⁷² The ratio of its subject imports to U.S. production was *** percent in 2018, *** percent in 2019, and *** percent in 2020.^{73 74}

⁶⁵ Chinese Respondents' Postconf. Br. at 6-7 ("Petitioner has clearly defined the scope to include MAE subassemblies that are imported separately from the finished MAE units. If these units are assembled in the United States by subcontractors or other independent companies, it is unclear why those assemblers would not constitute a separate domestic MAE industry. Chinese Respondents appreciate that the Commission at this preliminary stage does not have the data necessary to ascertain whether there are additional domestic MAE industries, and does not object to the Commission finding a single domestic industry at this preliminary phase.")

⁶⁶ MEC Postconf. Br. at 1-4.

⁶⁷ MEC Postconf. Br. at 4.

⁶⁸ MEC Postconf. Br. at 2.

⁶⁹ *** accounted for *** percent of U.S. production in 2020, and was tied with *** as the *** largest domestic producer of MAE. CR/PR at Table III-1.

⁷⁰ CR/PR at Table III-1.

⁷¹ CR/PR at Table III-8.

⁷² CR/PR at Table III-8.

⁷³ CR/PR at Table III-8.

⁷⁴ *** submitted incomplete financial data in its U.S. producer questionnaire. CR/PR at VI-1 n.1.

During the POI, *** primary interest appears to have been domestic production given its limited volume of subject imports. No party has argued for its exclusion from the domestic industry. We therefore find that appropriate circumstances do not exist to exclude *** from the domestic industry as a related party.

***.⁷⁵ *** imports of subject merchandise were *** units in 2018, *** units in 2019, and *** units in 2020.⁷⁶ *** indicated that ***.⁷⁷ The ratio of its subject imports to U.S. production was *** percent in 2018, *** percent in 2019, and *** percent in 2020.⁷⁸

During the POI, *** primary interest appears to have been domestic production given its relatively limited volume of subject imports. No party has argued for its exclusion from the domestic industry. We therefore find that appropriate circumstances do not exist to exclude *** from the domestic industry as a related party.

***.⁷⁹ *** imports of subject merchandise were *** units in 2018, *** units in 2019, and *** units in 2020.⁸⁰ The ratio of its subject imports to U.S. production was *** percent in 2018, *** percent in 2019, and *** percent in 2020.⁸¹ *** and indicated that ***.⁸² ⁸³

*** primary interest appears to have been in the importation of subject merchandise, given that its ratio of subject imports to domestic production was *** high throughout the POI and its stated reasons for importing subject merchandise were lowering costs and increasing sales of high-volume MAE products. Given these considerations, we find that appropriate circumstances exist to exclude *** from the domestic industry as a related party.

***.⁸⁴ *** imports of subject merchandise were *** units in 2018, *** units in 2019, and *** units in 2020.⁸⁵ The ratio of *** subject imports to its U.S. production was *** percent

⁷⁵ *** accounted for *** percent of U.S. production in 2020, and was the *** largest domestic producer of MAE. CR/PR at Table III-1.

⁷⁶ CR/PR at Table III-9.

⁷⁷ CR/PR at Table III-9.

⁷⁸ CR/PR at Table III-9.

⁷⁹ *** accounted for *** percent of U.S. production in 2020, and was the smallest domestic producer of MAE. CR/PR at Table III-1.

⁸⁰ CR/PR at Table III-10.

⁸¹ CR/PR at Table III-10.

⁸² CR/PR at Tables III-1 & III-10.

⁸³ *** provided an incomplete U.S. producer questionnaire with only partial data. CR/PR at VI-1 n.1. MEC reported capital expenditures totaling \$*** in 2018, \$*** in 2019, and \$*** in 2020. *** U.S. Producer Questionnaire at III-9a. MEC reported research and development expenses totaling \$*** in 2018, \$*** in 2019, and \$*** in 2020. *Id.*

⁸⁴ *** accounted for *** percent of U.S. production in 2020 and was tied with *** as the *** largest domestic producer of MAE. It *** the petitions. CR/PR at Table III-1.

⁸⁵ CR/PR at Table III-11.

in 2018, *** percent in 2019, and *** percent in 2020.⁸⁶ *** indicated that it imported subject merchandise during the POI in order to ***.⁸⁷ *** reported capital expenditures totaling \$*** in 2018, \$*** in 2019, and \$*** in 2020; it reported research and development expenses totaling \$*** in 2018, \$*** in 2019, and \$*** in 2020.

The record evidence is mixed on whether *** primary interest was in domestic production or importation. Although *** ratio of subject imports to domestic production was high throughout the POI, the ratio declined from 2018 to 2020 and *** domestic production slightly exceeded its subject imports in the last year of the POI. *** capital expenditures and research and development expenses, described above, reflected a commitment to domestic production. Moreover, no party has argued for *** exclusion from the domestic industry. On balance, we find that appropriate circumstances do not exist to exclude *** from the domestic industry under the related party provision.

***.⁸⁸ *** imports of subject merchandise were *** units in 2018, *** units in 2019, and *** units in 2020.⁸⁹ *** indicated that ***.⁹⁰ The ratio of its subject imports to U.S. production was *** percent in 2018, *** percent in 2019, and *** percent in 2020.⁹¹

During the POI, *** primary interest appears to have been domestic production, given its relatively limited volume of subject imports. No party has argued for its exclusion from the domestic industry. Accordingly, we find that appropriate circumstances do not exist to exclude *** from the domestic industry as a related party.

***.⁹² *** imports of subject merchandise were *** units in 2018, *** units in 2019, and *** units in 2020.⁹³ The ratio of *** subject imports to its U.S. production was *** percent

⁸⁶ CR/PR at Table III-11. Domestic producer *** owns 51 percent of ***. CR/PR at Table III-14. As discussed below, *** also imported subject merchandise during the POI. Total imports of subject merchandise by *** and *** were *** units in 2018, *** units in 2019, and *** units in 2020. CR/PR at Table III-14. The combined ratios of subject imports to U.S. production for *** and *** were *** percent in 2018, *** percent in 2019, and *** percent in 2020. *Id.*

⁸⁷ CR/PR at Table III-11.

⁸⁸ A petitioning firm, *** accounted for *** percent of U.S. production in 2020, and was the *** domestic producer of MAE. CR/PR at Table III-1.

⁸⁹ CR/PR at Table III-12.

⁹⁰ CR/PR at Table III-12.

⁹¹ CR/PR at Table III-12.

⁹² *** accounted for *** percent of U.S. production in 2020 and was the sixth largest producer. *** on the petitions. CR/PR at Table III-1.

⁹³ CR/PR at Table III-13.

in 2018, *** percent in 2019, and *** percent in 2020.⁹⁴ *** indicated that it imported subject merchandise due to *** from domestic MAE suppliers.⁹⁵ *** reported capital expenditures totaling \$*** in 2018, \$*** million in 2019, and \$*** in 2020.⁹⁶ *** also reported research and development expenses totaling \$*** in 2018, \$*** in 2019, and \$*** in 2020.⁹⁷

*** primary interest appears to have been in domestic production during the POI. Although *** ratio of subject imports to domestic production was high in 2018, its ratio declined and was much lower in 2019 and 2020. Further, as described above, *** had significant capital expenditures and research and development expenses, reflecting a commitment to domestic production. No party has argued for *** exclusion from the domestic industry. Given these considerations, on balance we find that appropriate circumstances do not exist to exclude *** from the domestic industry as a related party.

C. Conclusion

For the foregoing reasons, and in light of our domestic like product definition, we define a single domestic industry consisting of all U.S. producers of MAE, with the exception of ***.⁹⁸

99

⁹⁴ CR/PR at Table III-13. As discussed above, the combined ratios of subject imports to U.S. production for *** and *** were *** percent in 2018, *** percent in 2019, and *** percent in 2020. CR/PR at Table III-14.

⁹⁵ CR/PR at Table III-13.

⁹⁶ *** U.S. Producer Questionnaire at III-13a.

⁹⁷ *** U.S. Producer Questionnaire at III-13a

⁹⁸ As a result of this definition, the relevant summary table is Table C-2.

⁹⁹ As noted above, some U.S. producers may also implicate the related party provision on account of their relationships with foreign producers and exporters. In any final phase of these investigations, the Commission will further examine under the related party provision the implications, if any, of these parties' relationships.

V. Reasonable Indication of Material Injury by Reason of Subject Imports¹⁰⁰

A. Legal Standard

In the preliminary phase of antidumping and countervailing duty investigations, the Commission determines whether there is a reasonable indication that an industry in the United States is materially injured or threatened with material injury by reason of the imports under investigation.¹⁰¹ In making this determination, the Commission must consider the volume of subject imports, their effect on prices for the domestic like product, and their impact on domestic producers of the domestic like product, but only in the context of U.S. production operations.¹⁰² The statute defines “material injury” as “harm which is not inconsequential, immaterial, or unimportant.”¹⁰³ In assessing whether there is a reasonable indication that the domestic industry is materially injured by reason of subject imports, we consider all relevant economic factors that bear on the state of the industry in the United States.¹⁰⁴ No single factor is dispositive, and all relevant factors are considered “within the context of the business cycle and conditions of competition that are distinctive to the affected industry.”¹⁰⁵

Although the statute requires the Commission to determine whether there is a reasonable indication that the domestic industry is “materially injured or threatened with material injury by reason of” unfairly traded imports,¹⁰⁶ it does not define the phrase “by reason of,” indicating that this aspect of the injury analysis is left to the Commission’s reasonable exercise of its discretion.¹⁰⁷ In identifying a causal link, if any, between subject

¹⁰⁰ Pursuant to Section 771(24) of the Tariff Act, imports from a subject country of merchandise corresponding to a domestic like product that account for less than 3 percent of all such merchandise imported into the United States during the most recent 12 months for which data are available preceding the filing of the petition shall be deemed negligible. 19 U.S.C. §§ 1671b(a), 1673b(a), 1677(24)(A)(i), 1677(24)(B).

Negligibility is not an issue in these investigations. Subject imports from China accounted for *** percent of total U.S. imports of MAE in the 12-month period (February 2020 to January 2021) preceding the filing of the petitions. CR/PR at Table IV-3.

¹⁰¹ 19 U.S.C. §§ 1671b(a), 1673b(a).

¹⁰² 19 U.S.C. § 1677(7)(B). The Commission “may consider such other economic factors as are relevant to the determination” but shall “identify each {such} factor ... and explain in full its relevance to the determination.” 19 U.S.C. § 1677(7)(B).

¹⁰³ 19 U.S.C. § 1677(7)(A).

¹⁰⁴ 19 U.S.C. § 1677(7)(C)(iii).

¹⁰⁵ 19 U.S.C. § 1677(7)(C)(iii).

¹⁰⁶ 19 U.S.C. §§ 1671b(a), 1673b(a).

¹⁰⁷ *Angus Chemical Co. v. United States*, 140 F.3d 1478, 1484-85 (Fed. Cir. 1998) (“{T}he statute does not ‘compel the commissioners’ to employ {a particular methodology}.”), *aff’g*, 944 F. Supp. 943, 951 (Ct. Int’l Trade 1996).

imports and material injury to the domestic industry, the Commission examines the facts of record that relate to the significance of the volume and price effects of the subject imports and any impact of those imports on the condition of the domestic industry. This evaluation under the “by reason of” standard must ensure that subject imports are more than a minimal or tangential cause of injury and that there is a sufficient causal, not merely a temporal, nexus between subject imports and material injury.¹⁰⁸

In many investigations, there are other economic factors at work, some or all of which may also be having adverse effects on the domestic industry. Such economic factors might include nonsubject imports; changes in technology, demand, or consumer tastes; competition among domestic producers; or management decisions by domestic producers. The legislative history explains that the Commission must examine factors other than subject imports to ensure that it is not attributing injury from other factors to the subject imports, thereby inflating an otherwise tangential cause of injury into one that satisfies the statutory material injury threshold.¹⁰⁹ In performing its examination, however, the Commission need not isolate the injury caused by other factors from injury caused by unfairly traded imports.¹¹⁰ Nor does

¹⁰⁸ The Federal Circuit, in addressing the causation standard of the statute, observed that “{a}s long as its effects are not merely incidental, tangential, or trivial, the foreign product sold at less than fair value meets the causation requirement.” *Nippon Steel Corp. v. USITC*, 345 F.3d 1379, 1384 (Fed. Cir. 2003). This was further ratified in *Mittal Steel Point Lisas Ltd. v. United States*, 542 F.3d 867, 873 (Fed. Cir. 2008), where the Federal Circuit, quoting *Gerald Metals, Inc. v. United States*, 132 F.3d 716, 722 (Fed. Cir. 1997), stated that “this court requires evidence in the record ‘to show that the harm occurred ‘by reason of’ the LTFV imports, not by reason of a minimal or tangential contribution to material harm caused by LTFV goods.’” See also *Nippon Steel Corp. v. United States*, 458 F.3d 1345, 1357 (Fed. Cir. 2006); *Taiwan Semiconductor Industry Ass’n v. USITC*, 266 F.3d 1339, 1345 (Fed. Cir. 2001).

¹⁰⁹ SAA at 851-52 (“{T}he Commission must examine other factors to ensure that it is not attributing injury from other sources to the subject imports.”); S. Rep. 96-249 at 75 (1979) (the Commission “will consider information which indicates that harm is caused by factors other than less-than-fair-value imports.”); H.R. Rep. 96-317 at 47 (1979) (“in examining the overall injury being experienced by a domestic industry, the ITC will take into account evidence presented to it which demonstrates that the harm attributed by the petitioner to the subsidized or dumped imports is attributable to such other factors;” those factors include “the volume and prices of nonsubsidized imports or imports sold at fair value, contraction in demand or changes in patterns of consumption, trade restrictive practices of and competition between the foreign and domestic producers, developments in technology and the export performance and productivity of the domestic industry”); accord *Mittal Steel*, 542 F.3d at 877.

¹¹⁰ SAA at 851-52 (“{T}he Commission need not isolate the injury caused by other factors from injury caused by unfair imports.”); *Taiwan Semiconductor Industry Ass’n*, 266 F.3d at 1345 (“{T}he Commission need not isolate the injury caused by other factors from injury caused by unfair imports Rather, the Commission must examine other factors to ensure that it is not attributing injury from other sources to the subject imports.” (emphasis in original)); *Asociacion de Productores de Salmon y Trucha* (Continued...)

the “by reason of” standard require that unfairly traded imports be the “principal” cause of injury or contemplate that injury from unfairly traded imports be weighed against other factors, such as nonsubject imports, which may be contributing to overall injury to an industry.¹¹¹ It is clear that the existence of injury caused by other factors does not compel a negative determination.¹¹²

Assessment of whether material injury to the domestic industry is “by reason of” subject imports “does not require the Commission to address the causation issue in any particular way” as long as “the injury to the domestic industry can reasonably be attributed to the subject imports.”¹¹³ The Commission ensures that it has “evidence in the record” to “show that the harm occurred ‘by reason of’ the LTFV imports,” and that it is “not attributing injury from other

(...Continued)

de Chile AG v. United States, 180 F. Supp. 2d 1360, 1375 (Ct. Int’l Trade 2002) (“{t}he Commission is not required to isolate the effects of subject imports from other factors contributing to injury” or make “bright-line distinctions” between the effects of subject imports and other causes.); *see also Softwood Lumber from Canada*, Inv. Nos. 701-TA-414 and 731-TA-928 (Remand), USITC Pub. 3658 at 100-01 (Dec. 2003) (Commission recognized that “{i}f an alleged other factor is found not to have or threaten to have injurious effects to the domestic industry, *i.e.*, it is not an ‘other causal factor,’ then there is nothing to further examine regarding attribution to injury”), *citing Gerald Metals*, 132 F.3d at 722 (the statute “does not suggest that an importer of LTFV goods can escape countervailing duties by finding some tangential or minor cause unrelated to the LTFV goods that contributed to the harmful effects on domestic market prices.”).

¹¹¹ S. Rep. 96-249 at 74-75; H.R. Rep. 96-317 at 47.

¹¹² *See Nippon Steel Corp.*, 345 F.3d at 1381 (“an affirmative material-injury determination under the statute requires no more than a substantial-factor showing. That is, the ‘dumping’ need not be the sole or principal cause of injury.”).

¹¹³ *Mittal Steel*, 542 F.3d at 876 & 78; *see also id.* at 873 (“While the Commission may not enter an affirmative determination unless it finds that a domestic industry is materially injured ‘by reason of’ subject imports, the Commission is not required to follow a single methodology for making that determination ... {and has} broad discretion with respect to its choice of methodology.”) *citing United States Steel Group v. United States*, 96 F.3d 1352, 1362 (Fed. Cir. 1996) and S. Rep. 96-249 at 75. In its decision in *Swiff-Train v. United States*, 793 F.3d 1355 (Fed. Cir. 2015), the Federal Circuit affirmed the Commission’s causation analysis as comports with the Court’s guidance in *Mittal*.

sources to the subject imports.”¹¹⁴ The Federal Circuit has examined and affirmed various Commission methodologies and has disavowed “rigid adherence to a specific formula.”¹¹⁵

The question of whether the material injury threshold for subject imports is satisfied notwithstanding any injury from other factors is factual, subject to review under the substantial evidence standard.¹¹⁶ Congress has delegated this factual finding to the Commission because of the agency’s institutional expertise in resolving injury issues.¹¹⁷

B. Data Issues

Petitioner argues that the best measure for apparent U.S. consumption in these preliminary investigations is to use units of finished MAE only.¹¹⁸ According to Petitioner, this approach avoids possible double-counting of finished units and subassemblies.¹¹⁹ At the conference, counsel for Chinese Respondents indicated agreement with Petitioner that the Commission should examine finished MAE only based on units for its analysis of apparent U.S. consumption.¹²⁰ However, in their postconference brief, Chinese Respondents argue that apparent U.S. consumption should be based on units combining both MAE subassemblies and finished MAE.¹²¹ Although MEC did not specifically address the data issue, MEC appears to suggest in its postconference brief that apparent U.S. consumption should be based on units of finished MAE.¹²²

As discussed above, the scope of these investigations includes both MAE subassemblies and finished MAE, which is the fully assembled downstream product. There are substantial

¹¹⁴ *Mittal Steel*, 542 F.3d at 873 (quoting from *Gerald Metals*, 132 F.3d at 722), 877-79. We note that one relevant “other factor” may involve the presence of significant volumes of price-competitive nonsubject imports in the U.S. market, particularly when a commodity product is at issue. In appropriate cases, the Commission collects information regarding nonsubject imports and producers in nonsubject countries in order to conduct its analysis.

¹¹⁵ *Nucor Corp. v. United States*, 414 F.3d 1331, 1336, 1341 (Fed. Cir. 2005); see also *Mittal Steel*, 542 F.3d at 879 (“*Bratsk* did not read into the antidumping statute a Procrustean formula for determining whether a domestic injury was ‘by reason’ of subject imports.”).

¹¹⁶ We provide in our discussion below a full analysis of other factors alleged to have caused any material injury experienced by the domestic industry.

¹¹⁷ *Mittal Steel*, 542 F.3d at 873; *Nippon Steel Corp.*, 458 F.3d at 1350, citing *U.S. Steel Group*, 96 F.3d at 1357; S. Rep. 96-249 at 75 (“The determination of the ITC with respect to causation is ... complex and difficult, and is a matter for the judgment of the ITC.”).

¹¹⁸ Petitioner’s Postconf. Br., Answers to Staff Questions, Exh. 1 at 5 & 8-9; Conf. Tr. at 235-236 (Brightbill).

¹¹⁹ Petitioner’s Postconf. Br., Answers to Staff Questions, Exh. 1 at 5-6.

¹²⁰ Conf. Tr. at 223-224 (Kahn).

¹²¹ Chinese Respondents’ Postconf. Br. at 16-19.

¹²² See e.g., MEC Postconf. Br. at 10.

differences in terms of size and weight between and among MAE subassemblies and finished MAE.¹²³ In these preliminary phase investigations, the Commission collected data on units of finished MAE, and on combined finished MAE and MAE subassemblies in terms of units, short tons, and value.¹²⁴

We recognize the benefits and limitations of these different measures.¹²⁵ As discussed below, in evaluating volume and market share, we have mainly considered units and short tons for both combined finished units and subassemblies and for finished units only.^{126 127}

C. Conditions of Competition and the Business Cycle

The following conditions of competition inform our analysis of whether there is a reasonable indication of material injury by reason of subject imports.

1. Demand Conditions

Demand for MAE generally tracks demand for new construction, particularly nonresidential construction.¹²⁸ Reported end uses for finished MAE products include equipment rental agencies and agricultural and construction applications.¹²⁹

The majority of market participants reported that U.S. demand for MAE declined or fluctuated since January 1, 2018.¹³⁰ Apparent U.S. consumption of all MAE based on short tons declined from *** short tons in 2018 to *** short tons in 2019, and *** short tons in 2020.¹³¹ Apparent U.S. consumption of all MAE based on units declined from *** units in 2018 to ***

¹²³ CR/PR at I-13-16 & Tables I-1-3.

¹²⁴ CR/PR at Tables IV-4, IV-5, and C-2.

¹²⁵ For example, the measures that combine units of MAE subassemblies and finished MAE may have double-counting issues since they encompass both the upstream and downstream products. Furthermore, a units-based measure gives equal treatment to items that may differ substantially in size and unit value. The short tons- and value-based measures account for size and unit value differences, but would not account for product mix issues. Finally, measures that include only finished MAE avoids the issues of double-counting and of equal treatment of disparate categories of finished units and subassemblies, but could also omit a portion of the domestic like product and subject imports.

¹²⁶ CR/PR at Tables IV-4, IV-5, and C-2.

¹²⁷ Chair Kearns finds data on completed units and on short tons to be the most probative; he gives little weight to the measure of units that combines finished MAE and subassemblies, as finished units and subassemblies differ vastly in size and value.

¹²⁸ CR/PR at II-10-11 & Figure II-1. Seasonally adjusted nonresidential construction spending fluctuated from 2018-20, and increased by 3.3 percent from January 2018 to December 2020. *Id.* Construction spending rose throughout 2018 and 2019, peaked in January 2020 and began to decline in March 2020, associated with the economic slowdown due to the COVID-19 pandemic. *Id.*

¹²⁹ CR/PR at II-9.

¹³⁰ CR/PR at Table II-4.

¹³¹ CR/PR at Tables IV-4 & C-2.

units in 2019 and *** units in 2020.¹³² Apparent U.S. consumption of finished MAE based on units declined from *** units in 2018 to *** units in 2019 and *** units in 2020.¹³³ Apparent U.S. consumption of finished MAE based on short tons declined from *** short tons in 2018 to *** short tons in 2019 and *** short tons in 2020.¹³⁴

2. Supply Conditions

The domestic industry consists of two large producers — JLG and Terex — accounting for approximately *** of domestic production of MAE in 2020, and four much smaller producers.¹³⁵ The domestic industry was the largest supplier of MAE to the U.S. market throughout the POI.¹³⁶ The domestic industry's market share of all MAE based on short tons declined from *** percent in 2018 to *** percent in 2019 and *** percent in 2020.¹³⁷ Its market share of all MAE based on units increased from *** percent in 2018 to *** percent in 2019, but then declined to *** percent in 2020.¹³⁸ Its market share of finished MAE based on units increased from *** percent in 2018 to *** percent in 2019, but then declined to *** percent in 2020.¹³⁹ Its market share of finished MAE based on short tons declined from *** percent in 2018 to *** percent in 2019 and *** percent in 2020.¹⁴⁰

Subject imports were generally the third-largest source of supply to the U.S. market during the POI.¹⁴¹ Their market share of all MAE based on short tons declined from *** percent in 2018 to *** percent in 2019, but then increased to *** percent in 2020.¹⁴² Their market share of all MAE based on units declined from *** percent in 2018 to *** percent in 2019, but then increased slightly to *** percent in 2020.¹⁴³ Their market share of finished MAE based on units declined from *** percent in 2018 to *** percent in 2019, but then increased to ***

¹³² CR/PR at Tables IV-4 & C-2.

¹³³ CR/PR at Table IV-5.

¹³⁴ CR/PR at Table IV-5.

¹³⁵ CR/PR at Table III-1. As discussed above, we have excluded a seventh producer, ***, from the domestic industry as a related party.

¹³⁶ CR/PR at Tables IV-4, IV-5, and C-2

¹³⁷ CR/PR at Table C-2.

¹³⁸ CR/PR at Table C-2.

¹³⁹ CR/PR at Table IV-5.

¹⁴⁰ CR/PR at Table IV-5.

¹⁴¹ CR/PR at Tables IV-4, IV-5, and C-2.

¹⁴² CR/PR at Table C-2.

¹⁴³ CR/PR at Table C-2.

percent in 2020.¹⁴⁴ Their market share of finished MAE based on short tons declined from *** percent in 2018 to *** percent in 2019, but then increased to *** percent in 2020.¹⁴⁵

Nonsubject imports were generally the second largest source of supply to the U.S. market during the POI.¹⁴⁶ Their market share of all MAE based on short tons increased from *** percent in 2018 to *** percent in 2019, but then declined to *** percent in 2020.¹⁴⁷ Their market share of all MAE based on units increased from *** percent in 2018 to *** percent in 2019 and *** percent in 2020.¹⁴⁸ Their market share of finished MAE based on units increased from *** percent in 2018 to *** percent in 2019, but then declined to *** percent in 2020.¹⁴⁹ Their market share of finished MAE based on short tons increased from *** percent in 2018 to *** percent in 2019, but then declined to *** percent in 2020.¹⁵⁰ The largest source of nonsubject imports during 2020 was Canada.¹⁵¹

3. Substitutability and Other Conditions

We find that there is a moderately high degree of substitutability between domestically produced MAE and subject imports from China.¹⁵² All six responding domestic producers and 8 of 11 responding importers reported that the domestic like product and subject imports were always or frequently interchangeable.¹⁵³

The record further indicates that price is one of several important factors in purchasing decisions for MAE. The sole purchaser responding to the lost sales and lost revenue survey named price, brand, and country of origin as the three most important factors in purchasing decisions.¹⁵⁴ In comparing domestically produced MAE and subject imports, half of the responding U.S. producers and a majority of responding U.S. importers reported that

¹⁴⁴ CR/PR at Table IV-5.

¹⁴⁵ CR/PR at Table IV-5.

¹⁴⁶ CR/PR at Tables IV-4, IV-5, and C-2.

¹⁴⁷ CR/PR at Table C-2.

¹⁴⁸ CR/PR at Table C-2.

¹⁴⁹ CR/PR at Table IV-5.

¹⁵⁰ CR/PR at Table IV-5.

¹⁵¹ CR/PR at IV-2.

¹⁵² CR/PR at II-12 & Table II-6. The degree of substitution between domestic and imported MAE depends upon such factors as relative prices, quality (*e.g.*, grade standards, defect rates, etc.), and conditions of sale (*e.g.*, price discounts/rebates, lead times between order and delivery dates, reliability of supply, product services, etc.). CR/PR at II-12.

¹⁵³ CR/PR at Table II-5.

¹⁵⁴ CR/PR at II-13.

differences other than price were only sometimes or never significant in purchasing decisions.¹⁵⁵

Six of 7 U.S. producers and 11 of 16 U.S. importers reported that the U.S. market for MAE was subject to distinct business cycles with sales of MAE tracking the construction industry and generally peaking in the second and third quarter of the year.¹⁵⁶

Finished MAE is subject to safety standards set by the American National Standards Institute (“ANSI”).¹⁵⁷ New ANSI standards became effective in June 2020.¹⁵⁸

During the POI, both the domestic like product and subject merchandise were sold predominantly to end-users, but also were sold in appreciable quantities to distributors and retailers.¹⁵⁹

U.S. producers sold MAE using short-term contracts, annual contracts, and spot sales in nearly equal measure.¹⁶⁰ By contrast, importers mostly sold subject merchandise using annual contracts and spot sales, lesser but appreciable quantities sold using short-term contracts, and very small quantities sold using long-term contracts.¹⁶¹

Domestically produced MAE primarily was sold produced to order, with appreciable quantities sold from inventory.¹⁶² Subject imports from China were sold overwhelmingly from inventory, with small quantities produced to order.¹⁶³

Raw materials accounted for *** percent of the COGS for MAE in 2018, *** percent in 2017, and *** percent in 2020.¹⁶⁴ MAE is primarily made of steel and fabricated steel parts.¹⁶⁵ U.S. producers use varying grades and thicknesses of hot-rolled plate and hot-rolled coil to

¹⁵⁵ CR/PR at Table II-6.

¹⁵⁶ CR/PR at II-9. Two producers and one importer reported that the business cycle is seasonal and mirrors the construction industry; one importer reported that sales of MAE to equipment rental agencies are highest in the second quarter and lower in the fourth and first quarter; and one importer reported that the industry cycle is seven years, and the market is subject to seasonality, peaking in the second and third quarter. CR/PR at II-9-10.

¹⁵⁷ CR/PR at II-3. According to Petitioner, meeting ANSI standards is not a legal requirement, but safety is considered a “critical need” and the ANSI standards are *de facto* required by purchasers. Petitioner’s Postconference Br. at 20.

¹⁵⁸ CR/PR at II-3-4.

¹⁵⁹ CR/PR at Table II-1.

¹⁶⁰ CR/PR at Table V-2.

¹⁶¹ CR/PR at Table V-2.

¹⁶² CR/PR at II-12.

¹⁶³ CR/PR at II-12.

¹⁶⁴ CR/PR at Table VI-1.

¹⁶⁵ CR/PR at V-1.

produce MAE, as well as a limited amount of steel tubes or bars and cold-rolled steel.¹⁶⁶ From 2018 to 2020, prices of hot-rolled coil increased overall by *** percent and prices of cut-to-length plate increased by *** percent.¹⁶⁷ Chinese Respondents contend that tariffs imposed pursuant to Section 232 of the Trade Expansion Act of 1962¹⁶⁸ (“section 232 tariffs”) increased the domestic industry’s raw material costs for steel during the POI.¹⁶⁹

MAE from China have been subject to additional 25-percent *ad volorem* tariffs under Section 301 of the Trade Act of 1974¹⁷⁰ (“section 301 tariffs”) since July 2018.¹⁷¹

D. Volume of Subject Imports

Section 771(7)(C)(i) of the Tariff Act provides that the “Commission shall consider whether the volume of imports of the merchandise, or any increase in that volume, either in absolute terms or relative to production or consumption in the United States, is significant.”¹⁷²

The volume of subject import shipments of all MAE based on short tons declined from *** short tons in 2018 to *** short tons in 2019 and *** short tons in 2020.¹⁷³ The market share of subject import shipments of all MAE based on short tons declined from *** percent in 2018 to *** percent in 2019, but then increased to *** percent in 2020.¹⁷⁴

The volume of subject import shipments of all MAE based on units declined from *** units in 2018 to *** units in 2019 and *** units in 2020.¹⁷⁵ The market share of subject import shipments of all MAE based on units declined from *** percent in 2018 to *** percent in 2019, but then increased to *** percent in 2020.¹⁷⁶

The volume of subject imports of finished MAE based on short tons declined from *** short tons in 2018 to *** short tons in 2019 and *** short tons in 2020.¹⁷⁷ The market share of

¹⁶⁶ CR/PR at V-1.

¹⁶⁷ CR/PR at V-1 & Figure V-1.

¹⁶⁸ 19 U.S.C § 1862.

¹⁶⁹ Chinese Respondents’ Postconf. Br. at 32-34 & Exh. 4, 7.

¹⁷⁰ 19 U.S.C. § 2411.

¹⁷¹ CR/PR at I-11.

¹⁷² 19 U.S.C. § 1677(7)(C)(i).

¹⁷³ CR/PR at Table C-2.

¹⁷⁴ CR/PR at Table C-2.

¹⁷⁵ CR/PR at Table C-2. The volume of subject imports of MAE declined from *** units in 2018 to *** units in 2019 and *** in 2020. CR/PR at Table IV-2.

¹⁷⁶ CR/PR at Tables IV-2 & C-2.

¹⁷⁷ CR/PR at Table IV-5.

subject imports of finished MAE based on short tons declined from *** percent in 2018 to *** percent in 2018, but then increased to *** percent in 2020.¹⁷⁸

The volume of subject imports of finished MAE based on units declined from *** units in 2018 to *** units in 2019, but then increased to *** units in 2020.¹⁷⁹ The market share of subject imports of finished MAE based on units declined from *** percent in 2018 to *** percent in 2019, but then increased to *** percent in 2020.¹⁸⁰

Based on the record in the preliminary phase of the investigations, we conclude that the volume of subject imports was significant both in absolute terms and relative to consumption in the United States during the POI.

E. Price Effects of the Subject Imports

Section 771(7)(C)(ii) of the Tariff Act provides that, in evaluating the price effects of subject imports, the Commission shall consider whether –

(I) there has been significant price underselling by the imported merchandise as compared with the price of domestic like products of the United States, and

(II) the effect of imports of such merchandise otherwise depresses prices to a significant degree or prevents price increases, which otherwise would have occurred, to a significant degree.¹⁸¹

As addressed in section IV.B.4. above, the record indicates that there is a moderately high degree of substitutability between domestically produced MAE and the subject imports and that price is an important consideration in purchasing decisions.

The Commission collected quarterly pricing data from U.S. producers and importers for four pricing products.¹⁸² Two domestic producers and nine importers provided usable pricing

¹⁷⁸ CR/PR at Table IV-5.

¹⁷⁹ CR/PR at Table IV-5.

¹⁸⁰ CR/PR at Table IV-5.

¹⁸¹ 19 U.S.C. § 1677(7)(C)(ii).

¹⁸² The four pricing products are as follows:

Product 1.-- Battery-powered scissor lift, with electric or hydraulic drive, with 18'-20' platform height elevation and 500 lb. to 600 lb. maximum lift capacity

Product 2.-- Diesel-powered four- or all-wheel drive articulating boom lift, with 44'-46' platform height elevation and 500 lb. to 1000 lb. maximum lift capacity

Product 3.-- Diesel-powered four- or all-wheel drive telescoping boom lift, with 64'-67' platform height elevation including jib option and 500 lb. to 1000 lb. maximum lift capacity

Product 4.-- Diesel-powered four- or all-wheel drive material telehandler, with 53'-57' maximum lift height and 10,000-lb. maximum lift capacity.

(Continued...)

data, although not all firms reported pricing for all products for all quarters.¹⁸³ Pricing data reported by these firms accounted for *** percent of U.S. producers' U.S. shipments of MAE and *** percent of importers' U.S shipments of MAE from China in 2020.^{184 185}

The pricing data show mixed underselling and overselling by the subject imports. Prices for subject imports were below those for the domestically produced MAE in *** of *** (or *** percent) of quarterly comparisons, while prices for subject imports were above those for domestically produced MAE in *** of *** (or *** percent) of quarterly comparisons.¹⁸⁶ There were *** units of subject imports in quarterly comparisons in which subject imports undersold the domestic like product (*** percent of the total); there were *** units of subject imports in quarterly comparisons in which subject imports oversold the domestic like product (*** percent of the total).¹⁸⁷ The margins of underselling ranged from 0.1 to 13.1 percent, and averaged 4.5 percent during the POI, while the margins of overselling ranged from 0.6 to 22.8 percent, and averaged 7.0 percent.¹⁸⁸

In addition to the pricing data, there is other information in the record indicating that subject imports were sometimes lower-priced than domestically produced MAE.¹⁸⁹ Petitioner has submitted price quotes and/or price lists obtained from various customers indicating that

(...Continued)

CR/PR at V-6-7.

¹⁸³ CR/PR at V-7.

¹⁸⁴ CR/PR at V-7.

¹⁸⁵ Petitioner argues that the data submitted by one significant importer are flawed because the data include value added in the United States. Petitioner also emphasizes that several U.S. importers did not submit questionnaire responses. Petitioner's Postconf. Br. at 27 and Exhibit 1. We do not find that the inclusion of U.S. value-added in prices of subject imports makes those prices *per se* unusable. Nonetheless, we note that the pricing product data reported by the U.S. importer *** whose data Petitioner questions accounted for approximately *** percent or more of the pricing data for subject imports for the two pricing products (1 and 2) on which it provided data. CR/PR at V-7 and n.25. Parties should provide any proposed alternative pricing products with specificity that they consider would permit apples-to-apples comparisons and increase representative coverage for pricing data in their comments on the draft questionnaires in any final phase of the investigations. In any final phase investigations, U.S. importers should note whether the pricing data to be reported in final phase questionnaires includes value-added in the U.S., and if so, to specify that amount. Parties are invited in their comments on draft questionnaires to state their position on the appropriateness or probity of including value-added in the U.S. in reported pricing data. 19 C.F.R. § 207.20(b).

¹⁸⁶ CR/PR at Table V-8.

¹⁸⁷ CR/PR at Table V-8.

¹⁸⁸ CR/PR at Table V-8.

¹⁸⁹ We note that although there were no confirmed lost sales by purchasers during the POI, only one of 20 purchasers identified in Petitioner's lost sales allegations submitted a questionnaire response. CR/PR at V-19.

subject imports were priced below the domestic like product.¹⁹⁰ At the conference, industry witnesses appearing on behalf of Petitioner testified that subject merchandise was sold at below the cost of production of domestically produced MAE and that subject imports were priced so low in certain instances that purchasers effectively had no choice other than to purchase MAE from China regardless of non-price factors in purchasing decisions for MAE.¹⁹¹

The Commission observes that concomitant with the evidence of underselling reviewed above, during the POI, the domestic industry's market share of all MAE and finished MAE as a share of quantity based on short tons declined by *** and *** percentage points, respectively. The domestic industry's market share of finished MAE as a share of quantity based on units declined by *** percentage points. Measured on these bases, subject import shipments captured market share directly at the expense of the domestic industry.^{192 193}

¹⁹⁰ Petitioner's Postconf. Br. at 27-29; Petition, Vol. I at 28-29.

¹⁹¹ Conf. Tr. at 25 (Ford) & 33 (Meyer).

¹⁹² The domestic industry's market share of all MAE as a share of quantity based on short tons declined from *** percent in 2018 to *** percent in 2019 and *** percent in 2020. Subject import shipments' market share of MAE as a share of quantity based on short tons declined from *** percent in 2018 to *** percent in 2019, but then increased to *** percent in 2020. Nonsubject import shipments' market share of MAE as a share of quantity based on short tons increased from *** percent in 2018 to *** percent in 2019, but then declined to *** percent in 2020. CR/PR at Tables IV-4 & C-2.

The domestic industry's market share of finished MAE as a share of quantity based on short tons declined from *** percent in 2018 to *** percent in 2019 and *** percent in 2020. Subject import shipments' market share of finished MAE as a share of quantity based on short tons declined from *** percent in 2018 to *** percent in 2019, but then increased to *** percent in 2020. Nonsubject import shipments' market share of finished MAE as a share of quantity based on short tons increased from *** percent in 2018 to *** percent in 2019, but then declined to *** percent in 2020. CR/PR at Table IV-5.

The domestic industry's market share of finished MAE as a share of quantity based on units increased from *** percent in 2018 to *** percent in 2019, but then declined to *** percent in 2020. Subject imports shipments' market share of finished MAE as a share of quantity based on units declined from *** percent in 2018 to *** percent in 2019, but then increased to *** percent in 2020. Nonsubject import shipments' market share of finished MAE as a share of quantity based on units increased from *** percent in 2018 to *** percent in 2019, but then declined to *** percent in 2020. CR/PR at Table IV-5.

¹⁹³ The domestic industry's market share of all MAE as a share of quantity based on units increased from *** percent in 2018 to *** percent in 2019, but then declined to *** percent in 2020. Subject import shipments' market share of MAE as a share of quantity based on units declined from *** percent in 2018 to *** percent in 2019, but then increased to *** percent in 2020. Nonsubject import shipments' market share of MAE as a share of quantity based on units increased from *** percent in 2018 to *** percent in 2019 and *** percent in 2020. CR/PR at Tables IV-4 & C-2.

We have also examined available data on price trends. During the POI, domestic prices generally increased for all four pricing products.¹⁹⁴ The data show that prices of subject imports from China increased for most pricing products during the POI.¹⁹⁵

We have also considered whether subject imports have prevented price increases for domestically produced MAE which otherwise would have occurred to a significant degree. The domestic industry's ratio of COGS to net sales fluctuated but increased overall by *** percentage points from 2018 to 2020, declining from *** percent in 2018 to *** percent in 2019, but then increasing to *** percent in 2020.¹⁹⁶ While the industry's unit COGS increased by *** per unit between 2018 and 2020, its net sales AUV only increased by *** during that same period.¹⁹⁷ As a result, the domestic industry experienced a cost-price squeeze during the POI. We note that apparent U.S. consumption declined by roughly *** percent over the POI, whether measured by MAE by units, short tons, or value or by units of finished MAE.¹⁹⁸ We intend to further assess the role of demand in domestic producers' ability to pass on rising costs in any final phase of these investigations.

In sum, the available information on the record in the preliminary phase of these investigations contains some evidence of underselling and a market share shift between domestically produced MAE and subject imports, and some evidence of a cost-price squeeze.

¹⁹⁴ CR/PR at Tables V-3-7. During January 2018-December 2020, domestic prices increased by *** percent for Product 1, *** percent for Product 2, *** percent for Product 3, and *** percent for Product 4. *Id.*

¹⁹⁵ During January 2018-December 2020, prices for subject imports from China increased by *** percent for Product 1 and *** percent for Product 3, while subject import prices for Product 2 declined by *** percent over the same period. CR/PR at Tables V-3-7. Importers of subject merchandise did not report pricing data for Product 4. CR/PR at Tables V-6-7.

Petitioner alleges that subject producers from China used aggressive pricing tactics during the POI including "feature dumping" (offering premium features at no additional expense) and by providing MAE product models to potential U.S. purchasers for an unrestricted period of time with no obligations. See Petitioner's Postconf. Br. at 18-19.

We observe that the current record reflects AUVs for subject import shipments, based on units, increased by approximately *** percent from 2018 to 2020, increasing from \$*** in 2018 \$*** in 2019 and \$*** in 2020. CR/PR at Table C-2. AUVs for subject import shipments based on short tons increased by approximately *** percent from 2018 to 2020, increasing from \$*** in 2018 to \$*** in 2019, but then declined to \$*** in 2020. *Id.* In any final phase investigations, we will further examine the reasons for the increase in AUVs for subject import shipments, including the role of changes in product mix.

¹⁹⁶ CR/PR at Table C-2.

¹⁹⁷ CR/PR at Table C-2. The domestic industry's unit COGS increased in each year of the POI, while its net sales AUV increased between 2018 and 2019, but then declined slightly in 2020. *Id.*

¹⁹⁸ CR/PR at Tables IV-4 and C-2

Given the moderately high degree of substitutability between the domestic like product and subject imports, the importance of price in purchasing decisions for MAE, and the significant volume of subject imports in the market, we cannot conclude, in the preliminary phase of these proceedings, that the subject imports were not having price effects on the domestic industry.¹⁹⁹

F. Impact of the Subject Imports²⁰⁰

Section 771(7)(C)(iii) of the Tariff Act provides that the Commission, in examining the impact of the subject imports on the domestic industry, “shall evaluate all relevant economic factors which have a bearing on the state of the industry.” These factors include output, sales, inventories, capacity utilization, market share, employment, wages, productivity, gross profits, net profits, operating profits, cash flow, return on investment, return on capital, ability to raise capital, ability to service debt, research and development, and factors affecting domestic prices. No single factor is dispositive and all relevant factors are considered “within the context of the business cycle and conditions of competition that are distinctive to the affected industry.”²⁰¹

Most of the domestic industry’s output indicia declined during the POI. From 2018 to 2020, the domestic’s industry’s production and U.S. shipments declined by *** percent and *** percent, respectively.²⁰² The domestic industry’s capacity declined by *** from 2018 to 2020 while capacity utilization declined by *** percentage points over the same period.²⁰³ End-of-period inventories declined by *** percent from 2018 to 2020.²⁰⁴

The domestic industry’s employment indicia generally declined during the POI. PRWs,²⁰⁵ hours worked,²⁰⁶ wages paid,²⁰⁷ and productivity²⁰⁸ declined steadily from 2018 to 2020. Hourly wages increased irregularly from 2018 to 2020.²⁰⁹

¹⁹⁹ See *American Lamb Co.*, 785 F.2d at 1001.

²⁰⁰ Commerce initiated its antidumping duty investigation based on an estimated dumping margin of 81.77 percent *ad valorem* for subject imports. *Certain Mobile Access Equipment and Subassemblies Thereof from the People’s Republic of China: Initiation of Less-Than-Fair-Value Investigation*, 86 Fed. Reg. 15922, 15926 (Mar. 25, 2021).

²⁰¹ 19 U.S.C. § 1677(7)(C)(iii). This provision was amended by the Trade Preferences Extension Act of 2015, Pub. L. 114-27.

²⁰² The domestic industry’s production declined from *** units in 2018 to *** units in 2019 and *** units in 2020. CR/PR at Table C-2. U.S. producers’ U.S. shipments declined from *** units in 2018, *** units in 2019 and *** units in 2020. *Id.*

²⁰³ The domestic industry’s capacity declined from *** units in 2018 to *** units in 2019, but increased slightly to *** units in 2020. CR/PR at Table C-2. The industry’s capacity utilization declined from *** percent in 2018 to *** percent in 2019 and *** percent in 2020. *Id.*

²⁰⁴ The domestic industry’s end-of-period inventories declined from *** units in 2018 to *** units in 2019 and *** units in 2020. CR/PR at Table C-2.

Most of the domestic industry's financial performance indicia declined over the course of the POI. From 2018 to 2020, the domestic industry's net sales (by value) declined by *** percent.²¹⁰ The domestic industry's gross profit declined by *** percent over this same period.²¹¹ Operating income declined by *** percent from 2018 to 2020,²¹² and operating income as a share of net sales declined by *** percentage points.²¹³ Net income declined steadily over the course of the POI with the industry experiencing net losses in 2020,²¹⁴ and net income as a share of net sales fell by *** percentage points from 2018 to 2020.²¹⁵

The domestic industry's capital expenditures and research and development expenses fluctuated, but declined overall by *** percent and *** percent, respectively, from 2018 to 2020.²¹⁶ Three of five responding domestic producers also reported negative effects on investment and on growth and development due to subject imports.²¹⁷

In sum, there is evidence in the current record that subject imports materially contributed to the domestic industry's declining trade and financial performance over the

(...Continued)

²⁰⁵ PRWs declined by *** percent from 2018 to 2020, declining from *** in 2018 to *** in 2019 and *** in 2020. CR/PR at Table C-2.

²⁰⁶ Total hours worked declined by *** percent from 2018 to 2020, declining from *** hours in 2018 to *** hours in 2019 and *** hours in 2020. CR/PR at Table C-2.

²⁰⁷ Wages paid declined by *** percent from 2018 to 2020, declining from \$*** in 2018 to \$*** in 2019 and \$*** in 2020. CR/PR at Table C-2.

²⁰⁸ Productivity declined from *** units per 1,000 hours in 2018 to *** units per 1,000 hours in 2019 and *** units per 1,000 hours in 2020. CR/PR at Table C-2.

²⁰⁹ Hourly wages paid to PRWs declined from \$*** per hour in 2018 to \$*** per hour in 2019, but then increased to \$*** per hour in 2020. CR/PR at Table C-2.

²¹⁰ By value, the domestic industry's net sales declined from \$*** in 2018 to \$*** in 2019 and \$*** in 2020. CR/PR at Table C-2.

²¹¹ The domestic industry's gross profit declined from \$*** in 2018 to \$*** in 2019 and \$*** in 2020. *Id.*

²¹² The domestic industry's operating income declined from \$*** in 2018 to \$*** in 2019 and \$*** in 2020. CR/PR at Table C-2.

²¹³ The domestic industry's operating income as a share of net sales declined from *** percent in 2018 to *** percent in 2019 and *** percent in 2020. CR/PR at Table C-2.

²¹⁴ The domestic industry's net income was \$*** in 2018, \$*** in 2019, and its net losses were \$*** in 2020. CR/PR at Table C-2.

²¹⁵ The domestic industry's net income as a share of net sales declined from *** percent to *** percent in 2019 and *** percent in 2020. CR/PR at Table C-2.

²¹⁶ The domestic industry's capital expenditures increased from \$*** in 2018 to \$*** in 2019, but then declined to \$*** in 2020. CR/PR Revised Table C-2 (INV-TT-054, Apr. 7, 2021). Its research and development expenses increased from \$*** in 2018 to \$*** in 2019, but then declined to \$*** in 2020. *Id.*

²¹⁷ CR/PR at Tables VI-10-11.

course of the POI. In particular, depending on the unit of measure as discussed above, subject import shipments captured market share from the domestic industry and we cannot conclude that subject imports did not have significant price effects. Moreover, most domestic producers reported negative effects on investment and on growth and development due to subject imports.²¹⁸ Given these considerations, we cannot conclude that subject imports did not have a significant negative impact.²¹⁹

We also have considered whether there are other factors that may have had an impact on the domestic industry to ensure that we are not attributing injury from such other factors to subject merchandise. We recognize that the domestic industry's performance was likely impacted by declining apparent U.S. consumption for MAE.²²⁰ As noted above, however, there is some evidence that subject imports gained market share at the expense of domestic producers. Thus, based on the record in these preliminary phase investigations, we cannot conclude that demand trends explain all the declines in the domestic industry's condition.²²¹ We will further examine this issue in any final phase investigations.

In addition, as discussed above, nonsubject imports were generally the second largest source of supply to the U.S. market during the POI.²²² However, the market share of nonsubject imports of MAE based on short tons and the market share of nonsubject imports of finished MAE based on short tons and units all declined overall from 2018 to 2020.²²³ Additionally, the available data indicate that AUVs for nonsubject imports were higher than for AUVs for subject imports throughout the POI.²²⁴ We therefore find, for purposes of these

²¹⁸ CR/PR at Tables VI-10-11.

²¹⁹ See *American Lamb Co.*, 785 F.2d at 1001.

²²⁰ CR/PR at Table C-2.

²²¹ Claiming that the domestic industry myopically focused its customer base on large consolidators to its own detriment rather than also pursuing small and midsize equipment rental company customers, Chinese Respondents and MEC argue that that the domestic industry's deteriorating performance during the POI was due to declining demand for MAE among large consolidators, which purportedly resulted from large consolidators deciding to age their fleets of MAE and forego certain maintenance costs due to the COVID-19 pandemic. See e.g., Chinese Respondents' Postconf. Br. at 7-8, 21; MEC Postconf. Br. at 11-12. Chinese Respondents also contend that other poor business decisions by the domestic industry contributed to the industry's declining performance during the POI, including offering volume discounts and engaging in costly remanufacturing operations for MAE. See e.g., Chinese Respondents' Postconf. Br. at 43. In any final phase investigations, we will further assess the effect of declining demand on the U.S. market for MAE and the role of the domestic industry's business decisions in its performance.

²²² CR/PR at Tables IV-4, IV-5, and C-2.

²²³ CR/PR at Tables IV-4, IV-5, and C-2.

²²⁴ CR/PR at Table C-2.

preliminary determinations, that nonsubject imports do not fully explain the domestic industry's declines in performance during the POI.

VI. Conclusion

For the reasons stated above, we determine that there is a reasonable indication that an industry in the United States is materially injured by reason of subject imports of MAE from China that are allegedly sold in the United States at less than fair value and allegedly subsidized by the government of China.

Separate and Concurring Views of Commissioner David S. Johanson

I write separately because I find that there is a reasonable indication that an industry in the United States is threatened with material injury by reason of subject imports of certain mobile access equipment and subassemblies thereof (MAE) that are allegedly sold in the United States at less than fair value and are allegedly subsidized by the government of China. I join sections I-V.C. of the Commission's views (Legal Standards for Preliminary Determinations, Background, Domestic Like Product, Domestic Industry and Related Parties, Negligible Imports, Legal Standard, Data Issues, and Conditions of Competition and the Business Cycle), except to the extent noted below.

I. REASONABLE INDICATION OF THREAT OF MATERIAL INJURY

A. Legal Standard

Section 771(7)(F) of the Tariff Act directs the Commission to determine whether the domestic industry is threatened with material injury by reason of the subject imports by analyzing whether "further dumped or subsidized imports are imminent and whether material injury by reason of imports would occur unless an order is issued or a suspension agreement is accepted."¹ The Commission may not make such a determination "on the basis of mere conjecture or supposition" and considers the threat factors "as a whole" in making its determination whether dumped or subsidized imports are imminent and whether material injury by reason of subject imports would occur unless an order issues.² In considering the existence of threat of material injury, I consider all factors set forth as relevant in the statute.³

¹ 19 U.S.C. § 1677(7)(F)(ii).

² 19 U.S.C. § 1677(7)(F)(ii).

³ See 19 U.S.C. § 1677(F)(i). These factors are as follows:

- (I) if a countervailable subsidy is involved, such information as may be presented to it by the administering authority as to the nature of the subsidy (particularly as to whether the countervailable subsidy is a subsidy described in Article 3 or 6.1 of the Subsidies Agreement), and whether imports of the subject merchandise are likely to increase,
- (II) any existing unused production capacity or imminent, substantial increase in production capacity in the exporting country indicating the likelihood of substantially increased imports of the subject merchandise into the United States, taking into account the availability of other export markets to absorb any additional exports,
- (III) a significant rate of increase of the volume or market penetration of imports of the subject merchandise indicating the likelihood of substantially increased imports,
- (IV) whether imports of the subject merchandise are entering at prices that are likely to have a significant depressing or suppressing effect on domestic prices and are likely to increase demand for further imports,

(Continued...)

B. Data Issues

While I concur with my Colleague's discussion of data issues, I note two additional points.

First, while the Commission typically assesses the volume of imports by using a standard industry measure by which the relevant products are sold or imports reported for HTSUS purposes, where the product includes a continuum of items of highly varying size, quality, and application, the Commission has preferred value-based measures.⁴

In this case, the scope includes both finished MAEs and MAE subassemblies.⁵ Evidence suggests there is a high degree of variation in unit value both within and between these categories: individual MAE units vary in value several hundred-fold from ***.⁶ MAE

(...Continued)

(V) inventories of the subject merchandise,

(VI) the potential for product-shifting if production facilities in the foreign country, which can be used to produce the subject merchandise, are currently being used to produce other products,

...

(VIII) the actual and potential negative effects on the existing development and production efforts of the domestic industry, including efforts to develop a derivative or more advanced version of the domestic like product, and

(IX) any other demonstrable adverse trends that indicate the probability that there is likely to be material injury by reason of imports (or sale for importation) of the subject merchandise (whether or not it is actually being imported at the time).

19 U.S.C. § 1677(7)(F)(i). To organize my analysis, I discuss the applicable statutory threat factors using the same volume/price/impact framework that applies to our material injury analysis. Thus, I discuss factors (I), (II), (III), (V), and (VI) in the analysis of subject import volume; factor (IV) in the analysis of import price effects; and factors (VIII) and (IX) in the analysis of impact. Factor (VII) concerning agricultural products does not apply in this investigation.

⁴ See, e.g., Ball Bearings from China, Inv. No. 731-TA-989 (prelim.), USITC Pub. 3504 (May 2002) at 8 n.38; Certain Bearings from China, France, Germany, Hungary, Italy, Japan, Romania, Singapore, Sweden, and the United Kingdom, Inv. Nos. AA1921-143, 731-TA-341, 731-TA-343-345, 731-TA-391-397, and 731-TA-399 (review), USITC Pub. 3309 (June 2000), vol. I at 26-27.

⁵ CR/PR at I-8 to I-10.

⁶ CR/PR at Tables E-1 and E-3. The average unit values and average weight of finished MAE shipped by U.S. producers is also greater than the AUVs and weight of finished MAE imported from China: in 2020, for example, the AUV of U.S. producers' U.S. shipments was \$*** compared to an AUV of U.S. importers' U.S. imports from China of \$***, and the average weight of U.S. producers' U.S. shipments was *** short tons compared to the average weight of U.S. importers' U.S. imports of *** short tons. CR/PR at Table IV-5. Unit-based volume comparisons tend to equate these diverse products.

subassemblies reportedly range in value by factors of tens of thousands, from a ***⁷ Variations in value likely correlate with variations in size, as heavy raw materials form a large part of the cost of producing finished MAE.⁸

Given this large variation in unit values, assessing volume trends as if all units were equally significant is potentially problematic. Accordingly, I place more emphasis on value as a measure of volume, and also on weight, where weight is available, as using short tons as a unit at least indirectly accounts for the relatively negligible size and value of some products. I note that volume trends in terms of value and short tons are similar, as discussed below.

Second, while Petitioner suggests assessing import volume without regard to MAE subassemblies,⁹ I am reluctant to do so. Commerce has placed both finished MAE and MAE subassemblies in the scope of the investigation at Petitioner's own behest, and Petitioner alleges that imports of both types of MAE products have caused material injury to a single domestic like product consisting of both. Thus, I focus my analysis on imports of all subject MAE, including both finished MAE and MAE subassemblies. Although this does raise double-counting concerns, the amount of double-counting was small over the preliminary POI measured in short tons or by value, and declined sharply along with imports of MAE subassemblies.¹⁰

Accordingly, I focus my analysis chiefly on the volume of all subject imports. Notwithstanding this, I have considered all units of measure and means of evaluating volume suggested by the parties, and the choice of which measures to emphasize does not affect my ultimate conclusion that the record contains a reasonable indication of a threat of material injury to a domestic industry.

⁷ CR/PR at Table E-2. For the final determination, I would be interested in ensuring that all reported "subassemblies" are actually such, even if they comprise a single item.

⁸ Fabricated steel components formed the largest single component of raw material costs, which in turn comprised between *** percent and *** percent of the domestic industry's net sales value. CR/PR at Tables VI-1, VI-4.

⁹ Pet. Post-Conf. Br., Exh. 1, at 5-6.

¹⁰ All U.S. imports of subassemblies were internally consumed in the United States to make finished MAE. CR/PR at II-1. Thus, the tonnage and value of imports of MAE subassemblies became incorporated into domestically produced finished MAE, but MAE subassembly imports from all sources were small compared of domestic shipments of finished MAE in terms of both short tons and value. U.S. importers' U.S. imports of MAE subassemblies decreased from *** short tons in 2018 to *** short tons in 2020, while U.S. producers' U.S. shipments of finished MAE were far larger, decreasing from *** short tons in 2018 to *** short tons in 2020. CR/PR at Tables IV-5 & IV-6. By value, U.S. importers' U.S. imports of MAE subassemblies decreased from \$*** in 2018 to \$*** in 2020, while U.S. producers' U.S. shipments of finished MAE decreased from \$*** in 2018 to \$*** in 2020. CR/PR at Tables IV-5 & IV-6.

C. Demand Conditions

While market participants' assessment of U.S. demand condition varied somewhat,¹¹ the record clearly reflects that both demand and apparent consumption were declining throughout the POI. Apparent consumption of MAE fell steadily by *** percent over the POI in terms of short tons and *** percent in terms of value.¹² Petitioner asserts that construction starts decreased in 2019 and even before the COVID-19 pandemic were expected to decline further.¹³ Terex's 2019 Annual Report stated that Terex cut back production of aerial work platforms as rental customers held back purchases over concerns regarding the outlook.¹⁴ There is no doubt that the COVID-19 pandemic had an impact in 2020 – both Petitioner and Respondents noted it diminished demand: Respondent Sinoboom asserting it reduced demand by 60 percent, while *** U.S. producers reported layoffs and shutdowns at least partly due to COVID.¹⁵

D. Likely Volume¹⁶

1. Trends in Import Volume

Whether measured in short tons or value, U.S. importers' shipments of imports from China decreased steadily and sharply over the POI. From 2018 through 2020, U.S. importers' shipments of imports from China decreased *** percent from *** short tons in 2018 to *** short tons in 2020; and by value decreased *** percent from \$*** in 2018 to \$*** in 2020.¹⁷

In relation to U.S. apparent consumption, however, subject imports increased in terms of short tons by *** percentage points from *** percent to *** percent of apparent

¹¹ A plurality of importers believed demand decreased, but equal numbers of U.S. producers believed it decreased or fluctuated; one producer and one importer reported an increase. CR/PR at Table II-4.

¹² CR/PR at Table C-2.

¹³ Pet. Br. 9-10 & Exh. 8.

¹⁴ Terex Corporation Form 10-K for the Year Ending December 31, 2019, at 28 ("AWP's revenue declines were greatest in North America and Western Europe as concerns over the global macroeconomic market for industrial equipment caused rental customers for aerials to hold back capital equipment purchases") & 33 ("The decrease in net sales was primarily due to weakening demand for aerial work platforms in North America and Western Europe in our AWP segment and changes in foreign exchange rates.") (Chinese Resp. Post-Conf. Br. Exh. 2).

¹⁵ CR/PR at II-11-12, III-5, & Table III-4.

¹⁶ The alleged subsidy programs are listed at pages I-5 through I-7 of the preliminary Staff Report.

¹⁷ CR/PR at Table C-2.

consumption, and increased by value by *** percentage points from *** percent to *** percent of apparent consumption.¹⁸

While these increases in market share were small, the record suggests that the increases in subject import volumes occurred primarily in the latter part of the POI. From 2018 to 2019, subject imports' share of the U.S. market decreased *** percentage points in terms of short tons, and then increased *** percentage points in 2020; by value, it increased by *** percentage points in 2019 and then by *** percentage points in 2020.¹⁹

I also note that arranged imports for 2020 of subject imports already total *** units, which equals *** percent of all subject imports for the year 2020 in unit terms (the only unit of measure available for arranged imports).²⁰ This suggests that subject import volumes may now be growing in absolute terms.

Accordingly, trends in import volumes suggest that while the volume of subject imports was clearly decreasing in absolute terms, and any increase in relation to the U.S. market was small over the preliminary POI as a whole, the increase in subject import market share accelerated as the POI progressed and will become significant in the imminent future.

2. Trends in the Chinese Industry

Usable questionnaire responses were received from six foreign producers or exporters, accounting for *** percent of U.S. imports of MAE reported in importer questionnaires.²¹ Among responding Chinese producers, capacity (measured in units) increased by *** percent from 2018 through 2020, while production increased by only *** percent, meaning that Chinese capacity utilization declined from *** percent in 2018 to *** percent in 2020.²² Chinese excess capacity, just among the responding producers, increased *** percent from 2018 to 2020, reaching *** units, equal to *** percent of 2020 U.S. consumption.²³

To be sure, the percentage of production that responding firms devoted to the Chinese home market increased sharply over the POI, from *** percent in 2018 to *** percent in 2020, and responding firms project that their capacity utilization will increase to *** percent in 2021 and to *** percent in 2022, and that their exports to the United States will decrease.²⁴ On the

¹⁸ CR/PR at Table C-2.

¹⁹ CR/PR at Table C-2.

²⁰ CR/PR at Tables IV-2, VII-7.

²¹ CR/PR at VII-3. As information regarding the industry in China was reported in terms of units, the following discussion is in unit terms except where otherwise noted.

²² CR/PR at Table VII-3.

²³ Calculated from CR/PR at Tables VII-3 & C-2.

²⁴ CR/PR at Table VII-3.

other hand, they also expect China’s total worldwide MAE exports to increase by *** percent from 2020 to 2022,²⁵ and two firms reported that ***, constraints that the end of the pandemic will relieve.²⁶ Throughout the POI, the United States was the largest single-country market in value terms for China’s exports of “forklift trucks and other lifting or handling work trucks and parts thereof” (a category that also includes some out-of-scope products).²⁷

Petitioner notes that three Chinese MAE producers, SANY Global, Xuzhou Construction Machinery Group Co. (“XCMG”), and Zoomlion Heavy Industry Science & Technology are some of the largest construction equipment manufacturers in the world but did not submit questionnaire responses.²⁸ ***²⁹ XCMG North America’s ***.³⁰ Several other Chinese manufacturers identified ***³¹

Thus, evidence indicates that significant new exporters may have supplied or recently entered the U.S. market but have not provided questionnaire responses, further suggesting that China’s available capacity and interest in exporting MAEs to the United States will likely increase in the imminent future.

3. Inventories

Foreign producers’ inventories of MAE increased *** percent from *** units at the end of 2018 to *** units at the end of 2020, rising from *** percent of trailing year shipments to *** percent.³² While U.S. importers’ inventories of MAE imported from China decreased slightly over the POI in absolute terms, from *** units in 2018 to *** units in 2020, these inventories increased sharply in relation to importers’ U.S. shipments: the ratio of importers’ inventories of MAE from China to their shipments increased (in terms of units) from *** percent of importers’ U.S. shipments in 2018 to *** percent in 2020.³³ These increased inventories of subject MAE both in China and in the United States have increased importers’ ability and incentive to further increase their U.S. shipments and market share.

²⁵ CR/PR at Table VII-3.

²⁶ CR/PR at VII-5. *See also id.* at IV-4 (U.S. importers note supply chain disruptions).

²⁷ CR/PR at Table VII-5. The United States accounted for 20.1 percent of the value of such exports in 2018 and 17.5 percent in 2020. *Id.* There are no known active antidumping or countervailing duty investigations or orders in third-country markets relating to MAE. CR/PR at VII-11.

²⁸ Pet. Post-conf. Br. 7.

²⁹ CR/PR at VII-3 n.5.

³⁰ CR/PR at VII-3 n.5.

³¹ CR/PR at VII-3 n.5.

³² CR/PR at Table VII-3.

³³ CR/PR at Table VII-6.

Based on all these considerations, I find that the record suggests that the volume of subject imports, which was significant during the period examined, is likely to increase substantially in the imminent future.

E. Likely Price Effects

Section 771(7)(F)(i)(IV) of the Act requires considering “whether imports of the subject merchandise are entering at prices that are likely to have a significant depressing or suppressing effect on domestic prices and are likely to increase demand for further imports.”³⁴

1. Data Issues

The Commission requested pricing product data for four pricing products, a battery-powered scissor lift and three all-wheel-drive diesel-powered vehicles.³⁵ Two U.S. producers and nine importers provided usable pricing data, which accounted for *** percent of U.S. producers’ reported shipments of MAE and *** percent of U.S. shipments of subject imports from China.³⁶

Petitioner comments that MEC, which ***, “finalized” its base-model MAE imports from China with “options” and “customer-specific requirements” installed in the United States.³⁷ Petitioner asserts that this vitiates the utility of pricing product comparisons. Yet, the Commission does not normally adjust pricing product data to account for activities performed in the United States or base pricing product comparisons on customs value as imported; it is the price at which an importer sells products in the United States that determines how they compete in the U.S. market. The pricing product definitions were suggested by Petitioner, and Petitioner does not explain how any “options” and “customer-specific requirements” offered with subject imports would undermine the comparability of domestic and imported products, nor how those installed options differ from options offered by U.S. producers.

Similarly, Petitioner alleges that importers engage in “feature dumping,” adding valuable features for free, which would distort price comparisons.³⁸ This allegation rests on one article stating that LGMG offers four-wheel-drive on its 60-foot boom as a standard feature because most customers desire it.³⁹ Yet, pricing products 2 and 3, which are boom products,

³⁴ 19 U.S.C. § 1677(7)(F)(i) (IV).

³⁵ CR/PR at V-6 to V-7.

³⁶ CR/PR at V-7.

³⁷ Pet. Post-Conf. Br. at 6 (quoting Conf. Tr. 159-60 (Hix)); CR/PR at V-7 & n.25.

³⁸ Pet. Post-Conf. Br. at 18.

³⁹ Pet. Post-Conf. Br. Exh. 16 (Lindsey Anderson, *Interview: Craig Paylor*, KHL Group LLP (May 28, 2020), at 1).

specify all-wheel-drive, so prices for both domestic products and subject imports would reflect the same features. I do not find this evidence persuasive.

Respondents assert that pricing product data are “skewed” because new ANSI standards took effect in June 2020; newer companies such as LGMG and Sinoboom made products only to the new standard, while U.S. companies were still selling older products that were grandfathered in.⁴⁰ To the extent that is the case, it could explain overselling by subject imports later in the POI, as discussed below.

2. Underselling

During the POI, quarterly average prices of U.S. importers’ shipments of MAE imported from China were higher than quarterly average prices for U.S. producers’ U.S. shipments of the same pricing products in a majority of comparisons, representing a majority of subject imports for which pricing product data were reported.⁴¹ Specifically, quarterly average prices for products imported from China were below quarterly average prices for U.S.-produced products in 14 of 34 instances (representing *** units of subject imports) and were above quarterly average prices for U.S.-produced products in the remaining 20 instances (representing *** units of subject imports).⁴² Quarterly average margins of underselling ranged from 0.1 percent to 13.1 percent, while quarterly average margins of overselling ranged from 0.6 and 22.8 percent above prices for the domestic product.⁴³

Furthermore, underselling decreased as the POI progressed: in 2018 there were *** instances of underselling by subject imports totaling *** units, and *** instances of overselling totaling *** units; in 2019 there were *** instances of underselling totaling *** units, and *** of overselling totaling *** units; while in 2020 there were just *** instances of underselling totaling only *** units, and *** instances of overselling totaling *** units.⁴⁴ Increased overselling in 2020 may result from ANSI standard differences, as Respondents point out. Yet, I do not find this pattern indicates that imports of the subject merchandise are “entering at prices that are likely to have a significant depressing or suppressing effect on domestic prices and are likely to increase demand for further imports.”⁴⁵

⁴⁰ Chinese Resp. Post-Conf. Br. 35.

⁴¹ CR/PR at V-18. Pricing data accounted for *** percent of U.S. producers’ shipments and *** percent of U.S. shipments of subject imports. CR/PR at V-7.

⁴² CR/PR at Table V-8.

⁴³ CR/PR at Table V-8.

⁴⁴ CR/PR at Table V-8.

⁴⁵ 19 U.S.C. § 1677(7)(F)(i) (IV).

I am aware that a minority of quarterly average price comparisons reported underselling by subject imports. My underselling analysis, however, focuses on evidence regarding the substantial majority of pricing product comparisons.

Petitioner has also supplied anecdotal evidence of price quotes at prices below U.S. producers' prices, or even below U.S. producers' cost of production.⁴⁶ Generally, I find such anecdotal evidence uninformative, unless it is accompanied by indications that the products involved represent significant volumes, as well as documentation indicating the terms of sale. Pricing product comparisons reflect known quantities of actual sales and are meant to be representative of products as a whole. In contrast, anecdotal evidence is selective and does not necessarily represent any significant numbers of products.⁴⁷

In this case, however, there is evidence that some new entrants to the market may use ***.⁴⁸ The volumes represented may be insignificant at present, but if successful such efforts could lead to increased market share in the future. As discussed above, there is also evidence that large new exporters have recently begun selling to the U.S. market.⁴⁹

Accordingly, while the record evidence indicates that the quarterly average prices of subject imports were typically greater than for domestic like products, particularly in 2020, I cannot say that there is no indication in the record that subject imports are entering the United States at prices that could lead to significantly increased import volumes in the imminent future.

3. Price Depression and Suppression

During the POI the domestic industry's prices increased for all four pricing products.⁵⁰ Despite these increasing prices, there is evidence that the domestic industry suffered a cost-price squeeze. The domestic industry's ratio of cost of goods sold to net sales increased from *** percent in 2018 to *** percent in 2020.⁵¹

Yet, the domestic industry more than managed to cover increasing costs of raw materials: while domestic producers' unit raw materials costs increased by *** percent from

⁴⁶ Pet. Post-Conf. Br. at 28-29.

⁴⁷ To the extent parties submit anecdotal evidence of pricing in the final phase, I would request that they provide any available documentation and explain the quantities involved.

⁴⁸ Pet. Post-Conf. Br. 29 (citing ***).

⁴⁹ CR/PR at VII-3 n.5.

⁵⁰ CR/PR at Tables V-7 & C-2 and Fig. V-6.

⁵¹ CR/PR at Table C-2.

\$*** to \$*** per MAE unit from 2018 through 2020, their ratio of raw materials costs to net sales declined from *** percent to *** percent.⁵²

I find the domestic industry's ability to increase prices more than enough to cover rising raw material costs to be notable, given that demand fell throughout the POI and apparent consumption decreased *** percent in terms of short tons, and *** percent in terms of value from 2018 through 2020.⁵³ Given this sharp decrease in consumption it is hardly surprising that domestic producers experienced some difficulty increasing prices so as to cover all the extra overhead costs that such a consumption collapse necessarily entails. In fact, it would have been surprising if the domestic industry's COGS ratio had not increased, given falling demand that began even before the COVID-19 pandemic.

Petitioner asserts that JLG's and Terex's latest price increases in 2021 have not sufficed to cover recent additional increases in raw material costs.⁵⁴ Yet, Petitioner also notes that construction demand is expected to decrease in 2021 with limited recovery in 2022.⁵⁵ Continued decreases in demand would normally lead to continued difficulties in covering increased costs. Furthermore, pricing product data do not evince any discernible relationship between changes in the prices of subject imports and domestic like products.⁵⁶

I do not find any indication in this record that imports are entering at prices likely to have a significant depressing or suppressing effect on domestic prices.

F. Likely Impact

After two years of falling consumption, the domestic industry's profitability has dwindled if not vanished entirely.⁵⁷ Yet, there is not evidence that financial distress has significantly impeded the domestic industry's ability to raise capital,⁵⁸ and Petitioner expects

⁵² CR/PR at Table VI-1.

⁵³ CR/PR at Table C-2.

⁵⁴ Pet. Post-Conf. Br. 31.

⁵⁵ Pet. Post-Conf. Br. 11.

⁵⁶ CR/PR at Table V-7; *compare* Fig. V-5 and Fig. V-6.

⁵⁷ The domestic industry's operating margin declined from *** percent in 2018 to *** percent in 2020, and its net margin decreased from *** percent in 2018 to *** percent in 2020. CR/PR at Table C-2.

⁵⁸ Some producers generally state that they did not invest as much as they would have over the POI, CR/PR at Table VI-11; but a sharp drop in demand and consumption that even preceded the COVID-19 pandemic would be expected to reduce investment below levels it would otherwise have reached. No domestic producer reports rejection of loans, lowering credit rating, or issuing stocks or bonds; only one reported reduced ability to service debt. CR/PR at Table VI-10.

that the impact of the COVID-19 pandemic will be temporary; at some point demand will improve, though it is not clear when.⁵⁹ Accordingly, I do not find the industry to be vulnerable.

Nevertheless, I find that the domestic industry is threatened with imminent material injury by reason of subject imports. As noted above, trends in subject import volume, the Chinese industry's capacity, arranged imports, and inventories suggest that subject imports, which gained a small amount of market share in the more recent part of the POI, are likely to increase their market penetration in the imminent future. There is also evidence that some new market entrants, some of which have not filed questionnaire responses, may be using low prices to facilitate this process. The record assembled in the final phase of the investigations should give the Commission with a better indication of any impact these developing trends may have on the domestic industry.

Further increases in subject imports' market share at the expense of domestic producers' share would diminish domestic producers' sales, or limit increases in domestic producers' sales as demand recovers, and reduce their ability to allocate fixed costs to sales, further reducing their already-low or nonexistent profitability.

I have considered the extent to which any threat of material injury to the domestic industry is attributable to other factors that will likely have an imminent impact on the domestic industry. The sharp drop in apparent consumption observed in 2020 appears likely to abate, if not reverse, as the economy recovers from the COVID-19 pandemic. Nonsubject imports had a larger share of the U.S. market by all measures throughout the POI and may also have gained market share over the POI.⁶⁰ Because questionnaire coverage of nonsubject imports was considerably lower than coverage of subject imports in the preliminary phase,⁶¹ it is likely that the market share of nonsubject imports reflected in the final phase record will be considerably higher, but the record of the preliminary phase does not indicate that nonsubject imports gained market share at a rate more significant than subject imports.⁶²

Accordingly, I find that subject imports threaten to inflict material injury on the domestic industry in the imminent future.

⁵⁹ Pet. Post-Conf. Br. 11.

⁶⁰ During the POI, nonsubject imports' U.S. market share decreased *** percentage points from *** percent in 2018 to *** percent in 2020 in terms of short tons; and increased *** percentage points from *** percent in 2018 to *** percent in 2020 in terms of value. CR/PR at Table C-2.

⁶¹ Importer responses covered an estimated *** percent of U.S. imports from nonsubject sources, compared to *** percent of subject imports. CR/PR at IV-1.

⁶² From 2018 to 2020, the market share of imports from nonsubject sources increased *** percentage points in terms of tons and *** percentage points in terms of value. CR/PR at Table C-2.

II. CONCLUSION

For the foregoing reasons, and based on the record in the preliminary phase of these investigations, I conclude that there is a reasonable indication that a domestic industry is threatened with material injury by reason of subject imports of MAE from China that are allegedly sold in the United States at less than fair value and that are allegedly subsidized by the government of China.

Part I: Introduction

Background

These investigations result from petitions filed with the U.S. Department of Commerce (“Commerce”) and the U.S. International Trade Commission (“USITC” or “Commission”) by the Coalition of American Manufacturers of Mobile Access Equipment (“CAMMAE,” “the Coalition,” or “Petitioner”),¹ alleging that an industry in the United States is materially injured and threatened with material injury by reason of subsidized and less-than-fair-value (“LTFV”) imports of certain mobile access equipment and subassemblies thereof (“mobile access equipment” or “MAE”)² from China. The following tabulation provides information relating to the background of these investigations.^{3 4}

Effective date	Action
February 26, 2021	Petitions filed with Commerce and the Commission; institution of Commission investigations (86 FR 12711, March 4, 2021)
March 18, 2021	Commerce’s notice of initiation of countervailing duty investigation (86 FR 15905, March 25, 2021); Commerce’s notice of initiation of antidumping duty investigation (86 FR 15922, March 25, 2021)
March 19, 2021	Commission’s conference
April 9, 2021	Commission’s vote
April 12, 2021	Commission’s determinations
April 19, 2021	Commission’s views

¹ The Coalition is comprised of JLG Industries, Inc. (“JLG”), Hagerstown, Maryland and Terex Corporation (“Terex”), Redmond, Washington.

² See the section entitled “The subject merchandise” in Part I of this report for a complete description of the merchandise subject in this proceeding.

³ Pertinent *Federal Register* notices are referenced in appendix A, and may be found at the Commission’s website (www.usitc.gov).

⁴ A list of witnesses appearing at the conference is presented in appendix B of this report.

Statutory criteria

Section 771(7)(B) of the Tariff Act of 1930 (the “Act”) (19 U.S.C. § 1677(7)(B)) provides that in making its determinations of injury to an industry in the United States, the Commission--

shall consider (I) the volume of imports of the subject merchandise, (II) the effect of imports of that merchandise on prices in the United States for domestic like products, and (III) the impact of imports of such merchandise on domestic producers of domestic like products, but only in the context of production operations within the United States; and. . . may consider such other economic factors as are relevant to the determination regarding whether there is material injury by reason of imports.

Section 771(7)(C) of the Act (19 U.S.C. § 1677(7)(C)) further provides that--⁵

In evaluating the volume of imports of merchandise, the Commission shall consider whether the volume of imports of the merchandise, or any increase in that volume, either in absolute terms or relative to production or consumption in the United States is significant. . . .In evaluating the effect of imports of such merchandise on prices, the Commission shall consider whether. . .(I) there has been significant price underselling by the imported merchandise as compared with the price of domestic like products of the United States, and (II) the effect of imports of such merchandise otherwise depresses prices to a significant degree or prevents price increases, which otherwise would have occurred, to a significant degree. . . . In examining the impact required to be considered under subparagraph (B)(i)(III), the Commission shall evaluate (within the context of the business cycle and conditions of competition that are distinctive to the affected industry) all relevant economic factors which have a bearing on the state of the industry in the United States, including, but not limited to. . . (I) actual and potential decline in output, sales, market share, gross profits, operating profits, net profits, ability to service debt, productivity, return on investments, return on assets, and utilization of capacity, (II) factors affecting domestic prices, (III) actual and potential negative effects on cash flow, inventories, employment, wages, growth, ability to raise capital, and investment, (IV) actual and potential negative effects on the existing development and production efforts of the domestic industry, including efforts to develop a derivative or more advanced version of the domestic like product, and (V) in {an antidumping investigation}, the magnitude of the margin of dumping.

⁵ Amended by PL 114-27 (as signed, June 29, 2015), Trade Preferences Extension Act of 2015.

In addition, Section 771(7)(J) of the Act (19 U.S.C. § 1677(7)(J)) provides that—⁶

(J) EFFECT OF PROFITABILITY.—The Commission may not determine that there is no material injury or threat of material injury to an industry in the United States merely because that industry is profitable or because the performance of that industry has recently improved.

Organization of report

Part I of this report presents information on the subject merchandise, alleged subsidy/dumping margins, and domestic like product. Part II of this report presents information on conditions of competition and other relevant economic factors. Part III presents information on the condition of the U.S. industry, including data on capacity, production, shipments, inventories, and employment. Parts IV and V present the volume of subject imports and pricing of domestic and imported products, respectively. Part VI presents information on the financial experience of U.S. producers. Part VII presents the statutory requirements and information obtained for use in the Commission’s consideration of the question of threat of material injury as well as information regarding nonsubject countries.

Market summary

Mobile access equipment combines a mobile (self-propelled or towed) chassis, with a lifting device (e.g., scissor arms, boom assemblies) for mechanically lifting persons, tools and/or materials capable of reaching a working height of ten feet or more, and a coupler that provides an attachment point for the lifting device, in addition to other components. The leading U.S. producers of MAE are JLG and Terex,⁷ while leading Chinese producers of MAE outside the United States include *** and ***. The leading U.S. importers of MAE from China are *** and ***, while the leading exporter of MAE from nonsubject sources (Canada) is Skyjack, Inc. (“Skyjack Canada”).⁸

⁶ Amended by PL 114-27 (as signed, June 29, 2015), Trade Preferences Extension Act of 2015.

⁷ Petitioner estimates that it accounts for approximately *** percent of U.S. shipments. Petitioner postconference brief, exh. “Answers to Staff Questions,” p. 8. Questionnaire responses show that the petitioner accounted for *** percent of U.S. production of MAE during 2020. See table III-1.

⁸ Skyjack Canada ***. Emails from ***, March 23-24, 2021. EDIS #738789 and #737928. Respondent MEC stated that Skyjack Canada is, by far, the largest exporter of MAE into the U.S. Transcript, p. 12 (McConkey). Petitioner ***. Petition, exh. I-3. Of note, Skyjack Canada’s U.S. subsidiary Skyjack (continued...)

Apparent U.S. consumption of MAE totaled approximately *** units (\$***) in 2020. At least seven firms were known to produce MAE in the United States during 2020.⁹ U.S. producers' U.S. shipments of MAE totaled *** units (\$***) in 2020, and accounted for *** percent of apparent U.S. consumption by quantity and *** percent by value. U.S. shipments of imports from subject sources totaled *** units (\$***) in 2020 and accounted for *** percent of apparent U.S. consumption by quantity and *** percent by value. U.S. shipments of imports from nonsubject sources totaled *** units (\$***) in 2020 and accounted for *** percent of apparent U.S. consumption by quantity and *** percent by value.

Summary data and data sources

A summary of data collected in these investigations is presented in appendix C, table C-1. Except as noted, U.S. industry data are based on questionnaire responses of seven firms that are believed to account for the vast majority of U.S. production of MAE during 2020.¹⁰ U.S. imports are based on questionnaire responses of 15 firms, which are believed to account for *** percent of imports of MAE from subject sources, *** percent from nonsubject sources, and *** percent from all sources during 2020. Foreign producer/exporter data is based on the response of six firms, who estimate they accounted for *** of the production of MAE in China during 2020.

(...continued)

Equipment Inc. ("Skyjack Equipment") is an importer ***. Skyjack Equipment's importer questionnaire response, question II-10.

⁹ In addition to its members, JLG and Terex, petitioner identified five other producers of MAE in the United States: Haulotte Group ("Haulotte"); Hy-Brid Lifts by Custom Equipment LLC ("Custom Equipment"); California Mechanical Engineering and Co. ("MEC"); Pettibone Traverse Lift, LLC ("Pettibone"); and Snorkel International, LLC ("Snorkel"). Six of these seven firms and one additional company, Xtreme Manufacturing ("Xtreme"), ***, submitted a U.S. producer questionnaire to this proceeding. Commission staff ***. Correspondence with ***, EDIS # 737950.

¹⁰ Petitioner estimated that its members accounted for *** percent of U.S. shipments of MAE during 2020. Petitioner's postconference brief, p. 8. Commission staff believe that *** account for *** U.S. shipments of MAE during 2020. Conference transcript, pp. 65-67.

Previous and related investigations

MAE has not been the subject of any prior antidumping and countervailing duty investigations in the United States.¹¹

Nature and extent of alleged subsidies and sales at LTFV

Alleged subsidies

On March 25, 2021, Commerce published a notice in the *Federal Register* of the initiation of its countervailing duty investigation on mobile access equipment from China.¹² Commerce identified the following government programs in China on which it is initiating an investigation:¹³

- A. Provision of Non-Steel Inputs for Less than Adequate Remuneration (LTAR)
 - 1. Provision of Electricity for LTAR
 - 2. Provision of Land-Use Rights for LTAR to the Mobile Access Equipment Industry
 - 3. Provision of Land-Use Rights for LTAR in Industrial and Other Special Economic Zones--
 - a. Ningxiang High-Tech Industrial Park in Changsha, Hunan Province
 - b. Linhang Industry Zone of Deqing County, Zhejiang Province
 - c. Jinan Innovation Zone, Shandong Province

¹¹ As described in the scope section below, subject merchandise includes chassis assemblies. On September 14, 2020, the Commission made preliminary determinations that an industry in the United States was materially injured by reason of imports of certain chassis and subassemblies thereof from China, that were alleged to be sold in the United States at LTFV and to be subsidized by the government of China. 85 FR 58386, September 18, 2020. On January 4, 2021 and March 4, 2021, Commerce made affirmative preliminary countervailing and antidumping duty determinations, respectively, on chassis from China. 86 FR 56, January 4, 2021 and 86 FR 12616, March 4, 2021. The Commission is currently in the final phase of these investigations.

There is no indication that the chassis subassemblies, as described in the scope of these investigations, and those in the *Chassis from China* proceeding are the same.

¹² 86 FR 15905, March 25, 2021.

¹³ Enforcement and Compliance, Office of AD/CVD Operations, Countervailing Duty Investigation Initiation Checklist, Certain Mobile Access Equipment and Subassemblies Thereof from the People's Republic of China, March 18, 2021, pp. 6-43.

4. Provision of Land-Use Rights to State-Owned Enterprises by the Government of China (“GOC”) for LTAR
 5. Provision of Diesel Engines for LTAR
 6. Provision of Lithium-ion Batteries for LTAR
- B. Provision of Steel Inputs for LTAR
1. Provision of Hot-Rolled Steel Sheet and Plate for LTAR
 2. Provision of Galvanized Steel for LTAR
- C. Provision of Structural Steel Shapes for LTAR
1. Provision of Wire Rod for Less than Adequate Remuneration
 2. Provision of Steel Bar for LTAR
 3. Provision of Steel Beams for LTAR
 4. Provision of Steel Channels for LTAR
 5. Provision of Steel Angles for LTAR
 6. Provision of Hollow Structural Shapes for LTAR
- D. Provision of Services for LTAR
1. Provision of International Ocean Shipping Services for LTAR
- E. Preferential Lending
1. Government Directed Debt Restructuring in the Mobile Access Equipment Industry
 2. Policy Loans to the Mobile Access Equipment Industry
- F. Subsidies Under the State Capital Operating Budget
1. Capital Injections and Other Payments from the State Capital Operating Budget
- G. Grant Programs
1. Foreign Trade Development Fund Grants
 2. Export Assistance Grants
 3. Interest Payment Subsidies
 4. Subsidies for the Development of Famous Brands and Chinese World Top Brands
 5. State Key Technology Fund Grants
 6. Grants for Retiring Outdated Capacity/Industrial Restructuring
 7. Grants for Energy Conservation and Emissions Reduction

- H. Income Tax and Direct Tax Programs
 - 1. Income Tax Reductions for High and New Technology Enterprises
 - 2. Income Tax Deduction for Research and Development Expenses under the Enterprise Income Tax Law
 - 3. Income Tax Credits for Domestically Owned Companies Purchasing Domestically Procured Equipment
 - 4. Import Tariff and Value-Added Tax Exemptions on Imported Equipment in Encouraged Industries
- I. Export Loans and Export-Import Bank of China Programs
 - 1. Export Loans from Chinese State-Owned Banks
 - 2. Export Seller's Credits
 - 3. Export Buyer's Credits
- J. Currency Allegation
 - 1. Currency Undervaluation

Alleged sales at LTFV

On March 25, 2021, Commerce published a notice in the *Federal Register* of the initiation of its antidumping duty investigation on mobile access equipment from China.¹⁴ Commerce's estimated dumping margin for mobile access equipment from China is 81.77 percent *ad valorem*.¹⁵

¹⁴ 86 FR 15922, March 25, 2021.

¹⁵ *Ibid.*

The subject merchandise

Commerce's scope

In the current proceeding, Commerce has defined the scope as follows:¹⁶

The merchandise covered by this investigation consists of certain mobile access equipment, which consists primarily of boom lifts, scissor lifts, and material telehandlers, and subassemblies thereof. Mobile access equipment combines a mobile (self-propelled or towed) chassis, with a lifting device (e.g., scissor arms, boom assemblies) for mechanically lifting persons, tools and/ or materials capable of reaching a working height of ten feet or more, and a coupler that provides an attachment point for the lifting device, in addition to other components. The scope of this investigation covers mobile access equipment and subassemblies thereof whether finished or unfinished, whether assembled or unassembled, and whether the equipment contains any additional features that provide for functions beyond the primary lifting function.

Subject merchandise includes, but is not limited to, the following subassemblies:

- *Scissor arm assemblies, or scissor arm sections, for connection to chassis and platform assemblies. These assemblies include: (1) Pin assemblies that connect sections to form scissor arm assemblies, and (2) actuators that power the arm assemblies to extend and retract. These assemblies may or may not also include blocks that allow sliding of end sections in relation to frame and platform, hydraulic hoses, electrical cables, and/or other components;*
- *boom assemblies, or boom sections, for connection to the boom turntable, or to the chassis assembly, or to a platform assembly or to a lifting device. Boom assemblies include telescoping sections where the smallest section (or tube) can be nested in the next larger section (or tube) and can slide out for extension and/or articulated sections joined by pins. These assemblies may or may not include pins, hydraulic cylinders, hydraulic hoses, electrical cables, and/or other components;*

¹⁶ 86 FR 15905, March 25, 2021; 86 FR 15922, March 25, 2021.

- *chassis assemblies, for connection to scissor arm assemblies, or to boom assemblies, or to boom turntable assemblies. Chassis assemblies include: (1) Chassis frames, and (2) frame sections. Chassis assemblies may or may not include axles, wheel end components, steering cylinders, engine assembly, transmission, drive shafts, tires and wheels, crawler tracks and wheels, fuel tank, hydraulic oil tanks, battery assemblies, and/or other components;*
- *boom turntable assemblies, for connection to chassis assemblies, or to boom assemblies. Boom turntable assemblies include turntable frames. Boom turntable assemblies may or may not include engine assembly, slewing rings, fuel tank, hydraulic oil tank, battery assemblies, counterweights, hoods (enclosures), and/or other components.*

Importation of any of these subassemblies, whether assembled or unassembled, constitutes unfinished mobile access equipment for purposes of this investigation.

Processing of finished and unfinished mobile access equipment and subassemblies such as trimming, cutting, grinding, notching, punching, slitting, drilling, welding, joining, bolting, bending, beveling, riveting, minor fabrication, galvanizing, painting, coating, finishing, assembly, or any other processing either in the country of manufacture of the in-scope product or in a third country does not remove the product from the scope. Inclusion of other components not identified as comprising the finished or unfinished mobile access equipment does not remove the product from the scope.

The scope excludes forklifts, vertical mast lifts, mobile self-propelled cranes and motor vehicles that incorporate a scissor arm assembly or boom assembly. Forklifts are material handling vehicles with a working attachment, usually a fork, lifted along a vertical guide rail with the operator seated or standing on the chassis behind the vertical mast. Vertical mast lifts are person and material lifting vehicles with a working attachment, usually a platform, lifted along a vertical guide rail with an operator standing on the platform. Mobile self-propelled cranes are material handling vehicles with a boom attachment for lifting loads of tools or materials that are suspended on ropes, cables, and/or chains, and which contain winches mounted on or near the base of the boom with ropes, cables, and/or chains managed along the boom structure. The scope also excludes motor vehicles (defined as a vehicle driven or drawn by mechanical power and manufactured primarily for use on public streets, roads, and highways, but does not include a vehicle operated only on a rail line pursuant to 49 U.S.C. 30102(a)(7)) that incorporate a scissor arm assembly or boom assembly. The scope further excludes vehicles driven or drawn by mechanical power operated only on a rail line that incorporate a scissor arm assembly or boom assembly. The scope also excludes: (1) Rail line vehicles, defined as vehicles with hi-rail gear or track wheels, and a fixed (nontelescopic) main boom, which perform operations on rail lines, such as laying rails, setting ties, or other rail maintenance jobs; and (2) certain rail line vehicle subassemblies, defined as chassis subassemblies and boom turntable subassemblies for rail line vehicles with a fixed (non-telescopic) main boom.

Tariff treatment

Based upon the scope set forth by Commerce, information available to the Commission indicates that the merchandise subject to these investigations is imported under statistical reporting numbers 8427.10.8020, 8427.10.8030, 8427.10.8070, 8427.10.8095, 8427.20.8020 and 8427.20.8090 of the Harmonized Tariff Schedule of the United States (“HTSUS” or “HTS”). The parts typically used in manufacturing mobile access equipment that are subject to these investigations are imported under HTS statistical reporting number 8431.20.0000. The 2021 general rate of duty is free for HTS subheadings 8427.10.80, 8427.20.80, and 8431.20.00. Decisions on the tariff classification and treatment of imported goods are within the authority of U.S. Customs and Border Protection.

Section 301 tariff treatment

Various Chinese products subject to these investigations are also subject to additional duties under Section 301 of the Trade Act of 1974. Imported Chinese products under the HTS subheadings 8427.10.80 and 8427.20.80 were subject to an additional 25 percent *ad valorem* import duty which went into effect as of July 6, 2018.¹⁷ Exclusions were granted based on descriptions at the statistical reporting number level and were granted to products imported under HTS statistical reporting number 8427.10.8020 on October 2, 2018. The exclusion was for, “Operator riding self-propelled aerial work platforms of a kind described in statistical note 1 to chapter 84, powered by an electric motor, with a load capacity not exceeding 1,400 kg”.¹⁸ This exclusion expired on December 31, 2020.

The product

Description and applications

MAE¹⁹ is machinery that combines a self-propelled mobile chassis with a direct, manually connected device with the purpose of lifting people, tools, or materials.²⁰ MAE covered by the scope of these investigations have a minimum working height of ten feet (figure I-1)²¹ or more, and also includes subassemblies (unassembled or unfinished). MAE covered by the scope of these investigations do not include forklifts, mobile self-propelled cranes, and motor vehicles that incorporate scissor arm attachments or boom attachments. Forklifts handle materials with a fork-like working attachment on a vertical mast with the operator seated or standing behind the mast. Self-propelled cranes are intended to solely handle loads that are suspended or lifted with ropes, cables, or chains.

¹⁷ 83 FR 28714 June 20, 2018.

¹⁸ 84 FR 52567 October 2, 2018.

¹⁹ MAE can also be referred to as aerial lifts, aerial work platforms (AWP), and/or mobile elevating work platforms (MEWP). Conference transcript, pp. 68-69 (Morris); MEC’s post conference brief p. 1.

²⁰ Petition, p. 6.

²¹ Petitioner indicates that the “vast majority” of MAE have a working height of ten feet or above. Conference transcript, p.122 (Brightbill and Morris).

Working height has a six-foot differential to platform height. A fully extended 60-foot boom lift would have a 60-foot platform height but a 66-foot working height. *Ibid.*, p. 120-121 (Morris).

Figure I-1
MAE: Working height

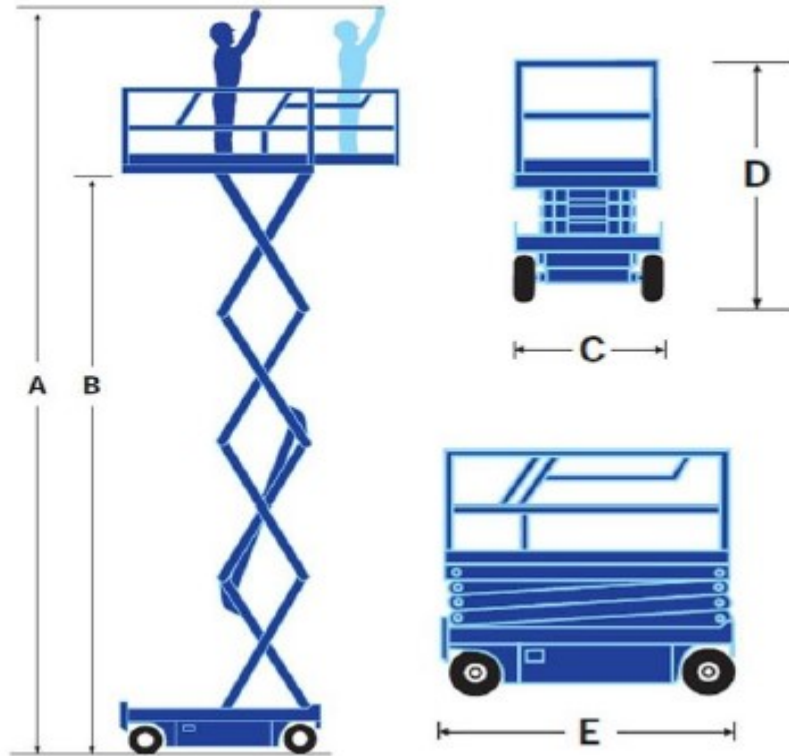

Note: The letter (A) represents working height, (B) platform height, (C) width, (D) stowed height, and (E) length.

Source: Petitioner, *Certain Mobile Access Equipment and Subassemblies Thereof from the People's Republic of China: Responses to Supplemental Questionnaire on Volume I of the Petition*, March 5, 2021, p.2.

There exists a range of goods that are classified as MAE, mainly scissor lifts, boom lifts, and telehandlers. Within this range of goods exists distinct differences between each model while each subset of MAE has different types. Scissor lifts (figure I-2) are hydraulic platforms that are designed to raise vertically. The ability to raise strictly vertically provides customers with a unique form of stability with reliable reach and greater carrying capacity than ladders and scaffolding.²² There are three main type of scissor lifts that differ not only from boom lifts but also one from another in weight capacity, height range, power type and best suited surfaces (table I-1).

Figure I-2
MAE: Scissor lift



Source: Petition, p.8.

Table I-1
MAE: Different characteristics of scissor lifts

Type	Weight Capacity (lbs)	Height Range (ft)	Power Type	Surfaces
Slab	500 – 1200	25 – 46	Electric	Smooth/Flat/Even
Rough Terrain	800 – 1500	32 – 59	IC (Engine)/Electric	Rough/Uneven/Outdoor
Single Man	300 – 500	17 – 46	Pushed/Electric	Smooth/Flat/Even

Source: Eqdepot, “The Complete Guide to Aerial Lifts”, <https://www.eqdepot.com/resources/the-complete-guide-to-aerial-lifts/> (retrieved March 5, 2021).

²² Eqdepot, “The Complete Guide to Aerial Lifts”, <https://www.eqdepot.com/resources/the-complete-guide-to-aerial-lifts/>, retrieved March 9, 2021.

Boom lifts are aerial work platforms that consist of a base with a hydraulic lift system attached that powers a crane as well as a platform or “bucket” that is primarily used to lift a single worker.²³ The boom lift can reach heights much higher than a standard scissor lift while also having the added ability to maneuver around obstacles by having hinges on the extension arm that can pivot. There are two main types of boom lifts, straight and articulating, with the difference between them being that the straight lift does not have the same number of hinges as the articulating lift (figure I-3). While this does not allow the straight lift to maneuver like the articulating lift, it does allow for it to reach the highest height of all lifts.²⁴ Boom lifts may also be referred to as: man lift, basket crane, bucket truck or cherry picker. Table I-2 presents the different characteristics of boom lifts.

Figure I-3
MAE: Straight telescoping boom lift (left) vs articulating boom lift (right)



Source: Petition, p. 9

Table I-2
MAEs: Different characteristics of boom lifts

Type	Weight Capacity (lbs)	Height Range (ft)	Power	Surface
Straight	500 – 1000	40 – 185	Electric/IC (Engine)	Smooth/Flat/Outdoor
Articulating	500 – 1000	30 – 140	Electric/IC (Engine)	Smooth/Flat/Outdoor

Source: Eqdepot, “The Complete Guide to Aerial Lifts”, <https://www.eqdepot.com/resources/the-complete-guide-to-aerial-lifts/> (retrieved March 5, 2021).

²³ Macallisterrentals, “What Type of Aerial Lift is Right for the Job?”, <https://www.macallisterrentals.com/aerial-lift-type-for-the-job/> (retrieved March 5, 2021).

²⁴ Eqdepot, “The Complete Guide to Aerial Lifts”, <https://www.eqdepot.com/resources/the-complete-guide-to-aerial-lifts/> (retrieved March 5, 2021).

Telehandlers, or telescopic handlers, are MAE that resemble forklifts but perform operations at greater heights and higher weight capacities (figure I-4). Telehandlers are mostly used for rough terrain in construction and agricultural environments.²⁵ Telehandlers are often equipped with 4-wheel drive and have a boom attached to a chassis that can lift materials 50 feet with capacities weighing more than 5,500 pounds. There are two main types of telehandlers, telescopic and rotating, with the difference being the rotating telehandler’s arm can swivel around the chassis in a 360-degree range of motion. Table I-3 presents the different characteristics of telehandlers.

Figure I-4
MAE: Telehandler



Source: Petition, p. 10.

Table I-3
MAE: Different characteristics of telehandlers

Type	Weight Capacity (lbs)	Height Range (ft)	Surface
Telescopic	5,500 – 12,000	18 – 55	Rough/Outdoor/Smooth/Flat
Rotating	5,500 – 12,000	18 – 55	Rough/Outdoor/Smooth/Flat

Source: Eqdepot, “The Complete Guide to Aerial Lifts”, <https://www.eqdepot.com/resources/the-complete-guide-to-aerial-lifts/> (retrieved March 5, 2021).

²⁵ Eqdepot, “The Complete Guide to Aerial Lifts”, <https://www.eqdepot.com/resources/the-complete-guide-to-aerial-lifts/> (retrieved March 5, 2021).

Generally, MAE consists of machines comprised primarily of fabricated steel parts and subassemblies, which are engine-powered or electric-powered, with mobile lifting devices, among other parts.²⁶ MAE subassemblies covered under the scope include: (1) scissor arm assemblies or scissor arm sections; (2) boom assemblies or boom sections; (3) mobile access equipment chassis assemblies; and (4) boom turntable assemblies. Figure I-5 presents several examples of these subassemblies.

Figure I-5
MAE: Subassemblies

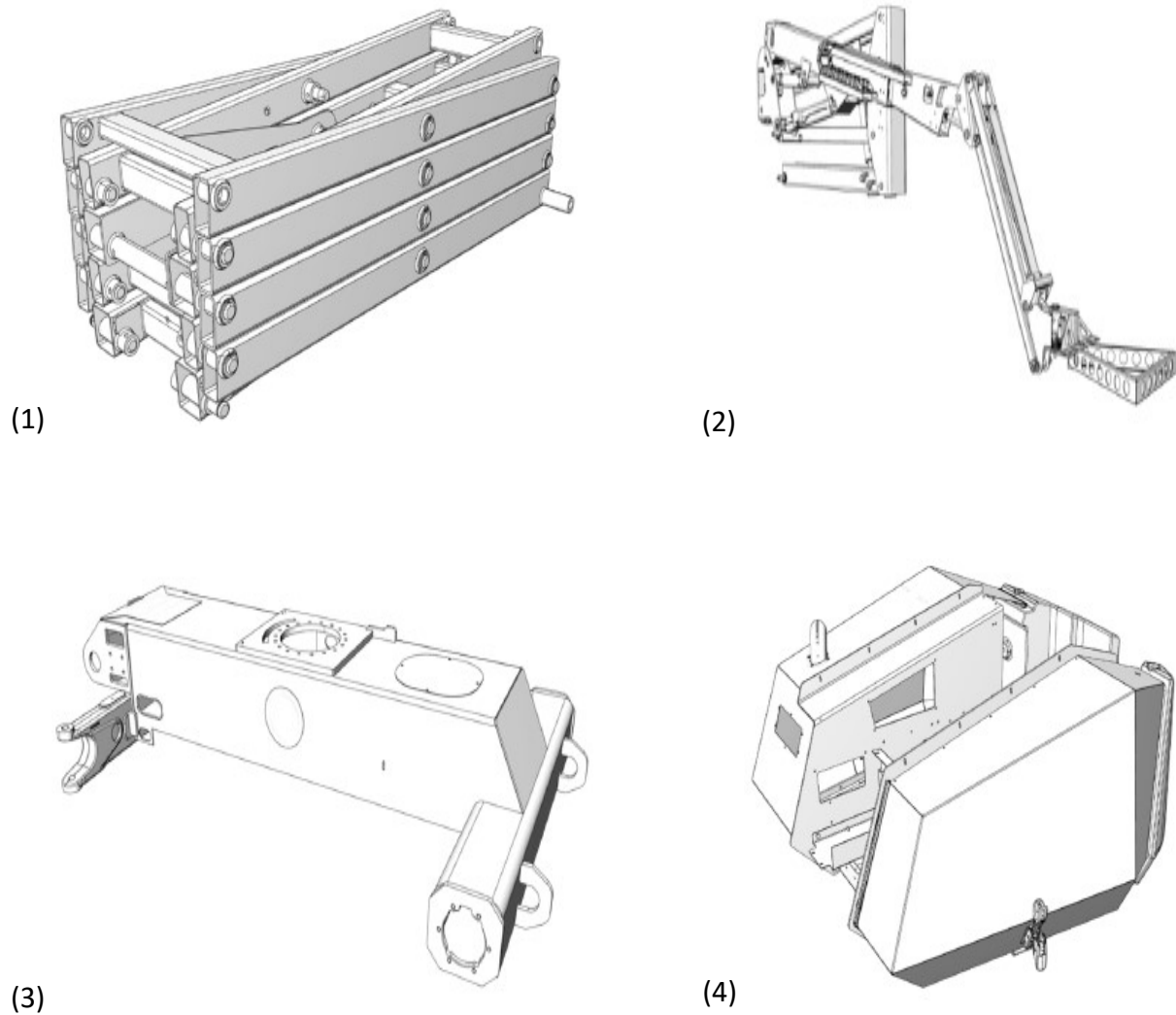

Source: Petition, pp. 11-14.

²⁶ Petition, p. 8.

The various MAE covered by the scope have a range of price points depending on the lift in question. Scissor lifts are usually priced between \$10,000 – \$15,000, while boom lifts are priced between \$20,000 – \$40,000. Renting a scissor lift costs around \$100 – \$150 a day or \$350 – \$500 weekly; whereas renting a boom lift costs \$250 – \$400 a day or \$1,000 – \$1500 a week.²⁷ These price discrepancies making renting an economic choice in many construction or consumer markets, where producers sell to rental companies who then rent to consumers. Equipment rental companies are the dominant purchasers of MAE in the U.S. market.²⁸

Domestic MAE and subject MAE have similar specifications with regards to weight capacity, height range, design, and overall use.²⁹ Parts used in domestic MAE can be replaced with subject MAE with little to no complications. Parts that are ordered for a certain producer have the capability to be used in most, if not all, domestically produced or imported MAE. Even within the domestic market, U.S. producers' parts can be interchanged from one to the other.³⁰ Handrails, engines, and various third-party parts all fall under this umbrella.

²⁷ Bigrentz, "Do You Really Want to Buy That Scissor or Boom Lift? Why Renting is a Better Option," September 20, 2016, <https://www.bigrentz.com/blog/why-renting-is-a-better-option>. (Retrieved March 5, 2021.)

²⁸ Conference transcript, pp. 150-151 (Kirschenmann).

²⁹ *Ibid.*, p. 117 (Ford).

³⁰ *Ibid.*, pp.116-117 (Ford); pp.213-214 (Paylor).

Manufacturing processes

The MAE manufacturing process primarily consists of four main steps: (1) fabrication, (2) wet and dry paint application, (3) sub-assembly and (4) final assembly.³¹ Manufacturers typically purchase or import steel and weld it into critical structural components such as frame/chassis, boom sections and turntable assemblies.³² After these major components are finished, they undergo a wet and dry preparation and paint application process.³³ Once painted, the subassemblies are fitted with electrical connections as well as tubing and hydraulic hose routing along with assembling the components into a boom assembly.³⁴ This boom assembly is then pinned and connected hydraulically and electrically to the turntable.³⁵ Control boxes and their components undergo a similar assembly process until they are fitted to the entire assembly. Once the individual fabrications are fully made, they undergo a final assembly process to be made into a finalized MAE. At this stage in the process, several safety tests are performed, recorded, and documented to test for quality or nonconformance issues.³⁶

The manufacturing process between domestic MAE and subject MAE appears to be very similar³⁷ with the difference being the level of automation along the assembly line which can vary drastically.³⁸ Production between individual types of MAE is also very similar with companies able to swap out assembly lines in the same day and have different kinds of lifts produced. All three types of MAEs can be produced in the same factory with the same inputs as other lines.³⁹

³¹ Petition, p. 13.

³² Petition, p. 13; Conference transcript pp. 116-117 (Ford).

³³ Petition, p. 13.

³⁴ *Ibid.*, p. 14.

³⁵ *Ibid.*, p. 14.

³⁶ Petition, p. 14.

³⁷ Conference transcript pp. 118, 215 (Ford, Paylor).

³⁸ Conference transcript p. 216 (Paylor).

³⁹ Conference transcript pp. 118-119 (Morris, Meyer).

Domestic like product issues

Petitioner proposes that the Commission should define a single domestic like product coextensive with the scope of these investigations, and in particular that the Commission should define all subject MAE, including scissor lifts, boom lifts, and telehandlers, to comprise a single like product.⁴⁰ For the purposes of these preliminary phase investigations, Chinese Respondents do not object to the petitioner's definition of a domestic like product but reserve the right to argue for separate domestic products in the event that these investigations proceed to a final phase.^{41 42}

U.S. producers and importers were asked to assess any differences between in-scope MAE subassemblies and completed MAE, based on factors the Commission typically considers in a semi-finished products analysis, including: (1) whether the upstream article is dedicated to the production of the downstream article or has independent uses; (2) whether there are perceived to be separate markets for the upstream and downstream articles; (3) differences in the physical characteristics and functions of the upstream and downstream articles; (4) differences in the costs or value of the vertically differentiated articles; and (5) the significance and extent of the processes used to transform the upstream into the downstream articles. Responses provided by firms are summarized in table I-4 below (where a 'no' response generally corresponds to indicating no differences or distinctions between complete MAE and in-scope subassemblies thereof).⁴³

⁴⁰ Petitioner's postconference brief, p. 5.

⁴¹ Chinese Respondents argue that the three major mobile access equipment subassemblies—scissor lifts, boom lifts, and telehandlers—may not constitute a single domestic like product under the Commission's analytical framework. Chinese Respondents note that a visual inspection and a cursory review of the petitioner's description makes clear that the subassemblies "have different physical characteristics, are used for different purposes, cannot be described as interchangeable, and are perceived differently by customers. Indeed, telehandlers move cargo, not people—and are therefore not considered AWP or MEWP, unlike scissor and boom lifts that are designed and used exclusively to lift people." Chinese Respondents' postconference brief, pp. 5-6.

Moreover, Chinese Respondents argue that within these mobile access equipment categories there is wide deviation among physical characteristics and uses, customer perceptions, production processes, and price. For example, a boom lift that extends less than 20 feet is not comparable to a boom lift that extends over 100 feet—the latter is not just a larger size of the former. *Ibid.*

⁴² Respondent MEC did not comment on issues relating to the domestic like product in its postconference brief.

⁴³ Appendix D presents the complete semi-finished products analysis.

U.S. producers and U.S. importers generally agree that there are no uses of subassemblies other than for the production of complete MAE; there is no market for subassemblies that is separate and distinct from the market for complete MAE; and, that there are no differences in physical characteristics and functions of subassemblies and complete MAE. There is no clear consensus on the last two factors. U.S. importers agree that there is no significant difference in the cost or value between subassemblies and complete MAE, while U.S. producers are more likely to state that there is a difference. Similarly, U.S. importers agree that it is not a significant process (i.e., the use of labor and/or capital) to transform a subassembly into a complete MAE, while a majority of U.S. producers state that it is a significant process.

Table I-4
MAE: U.S. producers and importers responses to semi-finished product analysis

Item	U.S. producers		U.S. importers	
	No	Yes	No	Yes
	Number of firms responding (count)			
Semi-finished.--				
Other uses	6	1	11	1
Separate market	5	2	9	3
Differences in characteristics	4	3	7	5
Differences in cost	3	4	7	5
Transformation intensive	3	4	6	5

Source: Compiled from data submitted in response to Commission questionnaires.

Part II: Conditions of competition in the U.S. market

U.S. market characteristics

MAE is used to lift people, tools, equipment, and other materials up to 180 feet or higher,¹ is primarily used in construction applications, and can also be used for agricultural, warehousing, and facility maintenance applications.² MAE can be self-propelled or towed, electric-powered or engine-powered, and includes various types of scissor lifts, boom lifts, and telehandlers.^{3 4} There is a wide variety of MAE, with capabilities to lift material of various weights to various heights.⁵ MAE can be imported into the United States either fully assembled or in subassemblies,^{6 7} and petitioner and respondents agreed that there are virtually no U.S. commercial shipments of subassemblies.⁸ Petitioner stated that purchasers' primary considerations are the height and weight capabilities.⁹

¹ The petition states that MAE is used to lift items up to 180 feet or higher, and Commerce's scope refers to a working height of 10 feet or more. See Part I for a description of Commerce's scope and a detailed discussion of the product.

² Petition, p. 8.

³ Boom lifts can have a hydraulic arm that is articulating (with arms that bend) or telescopic (with straight arms) and have a lifting arm with a platform or bucket attached to a grounded base. Telehandlers can also have a lifting arm with a platform or bucket attached to a grounded base, but its arms are generally telescoping. Petition, pp. 8-10.

⁴ There is a small, limited market for "indoor-only" (or "inside-only") MAE primarily of scissor lift models. Indoor-only MAE would not meet outside safety standards due to tip-over ratios and wind. Indoor-only models would also be electric powered. Petitioner's postconference brief, exh. 1, p. 49, and Chinese respondents' postconference brief, Attachment, p. 5.

⁵ MAE can range from equipment lifting 600 pounds up to 19 feet to equipment lifting 10,000 pounds up to 53 feet. Petition, p. 8.

⁶ Petitioner noted that Chinese producer LGMG opened a Pennsylvania facility in 2019 to assemble MAE subassemblies into the finished good. Petition, p. 10.

⁷ Firms may not import all subassembly parts at the same time.

⁸ All subassemblies are assembled into completed MAE. Conference transcript, pp. 49-50 (Brightbill, Ford) and 225 (Kirschenmann). The discussion in this section of the report pertains to fully assembled MAE.

⁹ Petitioner's postconference brief, p. 14.

Some U.S. producers also import Chinese MAE, these include both CAMMAE members JLG and Terex, as well as Haulotte, and respondent MEC.^{10 11} Respondent MEC stated that the three “dominant players” in the U.S. market (JLG, Terex, and Skyjack¹²) are 90 percent of the market, and accounted for 92 percent of scissor lift production and 88 percent of boom lift production in 2018.^{13 14}

Major purchasers of MAE are equipment rental companies which are split between four major national equipment rental firms (United Rentals, Sunbelt Rentals, H&E, and HERC Rentals, collectively the “consolidators”)¹⁵ and smaller, regional firms, (or local “mom and pop”) rental firms.^{16 17} Respondent MEC stated that to sell to the consolidators the MAE producer must be an approved or preferred supplier, able to meet the consolidators’ volume needs, and

¹⁰ MEC stated that its Chinese production of MAE is of MEC specifications and design through partner facilities in China, Korea, and Europe and in “standard ODM-OEM relationships.” Conference transcript, p. 157 (Hix).

¹¹ U.S. producers JLG, Haulotte, MEC, Terex, Snorkel, and Xtreme provided U.S. producer and U.S. importer questionnaire responses. These responses are reported separately throughout this section, unless otherwise indicated.

¹² See Part I and Part IV for a discussion on importer Skyjack Equipment and exporter and Canadian producer Skyjack Canada.

¹³ Respondent MEC’s postconference brief, p. 9.

¹⁴ Respondents provided two separate postconference briefs. Chinese firms Zhejiang Dingli Machinery Co., Ltd., Hunan Sinoboom, Intelligent Equipment Co., Ltd., Mantall Heavy Industry Co., Ltd., Lingong Group Jinan Heavy Machinery Co., Ltd., LGMG North America Inc., and the China Chamber of Commerce for Import and Export of Machinery and Electronic Products Subcommittee of Mobile Access Equipment Exporters, submitted a brief as “Chinese Respondents”, and U.S. producer and importer MEC submitted a separate respondent brief.

¹⁵ Respondents stated that there has been consolidation among the largest national equipment rental firms: “These very large and extremely well financed companies began to buy up multiple regional independent stores and consolidate them” in the late 1990s. Conference transcript, p. 142 (Paylor) and respondent MEC’s postconference brief pp. 10-11.

¹⁶ United Rentals is the largest equipment rental firm with more than 1,100 stores nationwide. Conference transcript, p. 140 (Paylor).

¹⁷ Respondent Sinoboom stratified purchasers into national, regional, and local. According to Sinoboom, national purchasers refers to the consolidators, regional purchasers have 10 to 20 stores across multiple states, and local purchasers have 1 or 2 stores in a city or state. Conference transcript, p. 220 (Kirschenmann).

be willing to be part of a trade package.^{18 19 20} Rental fleets keep MAE for 4 to 8 years before they are replaced,²¹ however, U.S. producer Terex and respondent Sinoboom noted that the major consolidators are able to “age” their fleet.²² Respondent Sinoboom added that consolidators have different purchasing behaviors than smaller rental agencies.²³ Petitioner argued that due to the consolidators’ national distribution network there is a lower barrier to entry, that purchasers typically carry multiple brands, and the cost of switching or adding brands is minimal.^{24 25} Respondent MEC stated that large rental companies focus on “fleet uniformity” and prefer to source products from a limited number of brands and companies.²⁶

Apparent U.S. consumption of MAE decreased during 2018-20. Overall, apparent U.S. consumption in 2020 was *** percent lower than in 2018, on a units basis.

ANSI standards

Completed MAE is subject to safety standards set by the American National Standards Institute (“ANSI”). Meeting ANSI standards is not a legal requirement, but safety is considered a “critical need” and the ANSI standards are de facto required by purchasers.²⁷ New ANSI standards were published in May 2020 and became effective in June 2020, and they are

¹⁸ Respondent MEC added that MEC, JLG, SkyJack and Genie are among “the few” approved suppliers for the consolidators. Conference transcript, pp. 202-203 (Hix).

¹⁹ Petitioner and respondents disagreed on whether the barrier to entry into the MAE market was low due to the consolidators’ national distribution network or high due to the requirements to sell to a consolidator. Conference transcript, pp. 19 (Brightbill) and 202-203 (Hix)

²⁰ Respondent MEC explained a trade package as when the supplier “will be required to take a certain amount of used product, their used product, on trade to then dispose of essentially so they don't have to go into the secondary market.” Conference transcript, p. 201 (Hix).

²¹ Conference transcript pp. 210 (Hix)

²² Conference transcript, pp. 80-81 (Meyer) and 207-208 (Kirschenmann).

²³ Respondent Sinoboom stated that consolidators were able to “stretch the age of their current fleet and leverage existing inventory across their different stores” and purchased fewer MAE due to the economic slowdown associated with the COVID-19 pandemic. Smaller rental agencies with smaller fleets were unable to do so, and demand for MAE in the smaller rental companies was stable throughout the period. Conference transcript, pp. 207-210 (Kirschenmann, Kahn, Hix)

²⁴ Petitioner’s postconference brief, pp. 11-12, and Conference transcript, p. 19 (Brightbill).

²⁵ Petitioner also argued that Chinese producers are “actively seeking additional inroads with some of the largest rental companies in the country” after establishing a presence with small- and medium-sized companies. Petitioner’s postconference brief, p. 12.

²⁶ Respondent MEC’s postconference brief, p. 11; *see also* Conference transcript, 201-202 (Hix) (consolidators want preferred suppliers, price competitiveness, ability to meet volume, and trade packages).

²⁷ Petitioner’s postconference brief, p. 20.

consistent with the standards in Europe, Australia, and Canada.²⁸ Petitioner noted that U.S. producers' MAE is "generally consistent" with ANSI standards.²⁹ Petitioner argued that the new standards had a "modest effect on pricing" and estimated that the standards increased prices by *** percent.^{30 31} Chinese respondents stated that products made before the new standards went into effect can be "legacied in" as compliant, but there may be issues with liability and insurance, thus, older MAE "may be replaced faster than they would otherwise."³² Respondent MEC added that there was excess inventory of MAE that did not meet the new ANSI standards which competed directly with new ANSI standards compliant MAE.³³

Secondary refurbished MAE market

A secondary market of refurbished or remanufactured MAE exists, but petitioner and Chinese respondents disagree regarding the size of this market. Petitioner stated that the refurbished market is "miniscule" and accounted for ***.³⁴ Chinese respondents argued that refurbished MAE is about 60 percent of the cost of a new MAE, and refurbished MAE compete directly with new MAE.^{35 36}

²⁸ Respondent MEC argued that production of MAE subject to these new ANSI standards are targeted for the global market, not the U.S. market. Respondent MEC's postconference brief, p. 14.

²⁹ Petitioner's postconference brief, exh. 1, pp. 45-46.

³⁰ Petitioner's postconference brief, exh. 1, pp. 47-48.

³¹ See Part V for a discussion on how the ANSI standard implementation impacted reported price data.

³² Chinese respondents' postconference brief, Attachment, p. 4.

³³ Respondent MEC's postconference brief, p. 14.

³⁴ Petitioner's postconference brief, exh. 1, p. 51.

³⁵ Petitioner's postconference brief, p. 36 and conference transcript, pp. 147-148 and 172-173 (Paylor).

³⁶ Chinese respondents noted that trade-ins of MAE can be used to discount new equipment. Chinese respondents' postconference brief, pp. 36-37.

Section 301 tariffs

MAE have been subject to section 301 tariffs of 25 percent since July 2018.³⁷ Some MAE products received exclusions from section 301 tariffs throughout the period including electric scissor MAE that received an exclusion from July 2019 to December 2020.^{38 39}

Channels of distribution

U.S. producers sold mainly to end users throughout 2018-20, while importers' shipments shifted from distributors and retailers in 2018 to mostly sales to end users by 2020.⁴⁰ (table II-1).

³⁷ MAE and subassemblies classified under HTS 8427.10.80, 8427.20.80 and 8431.20.00, were included in "List 1" of the Section 301 tariffs. *Notice of Action and Request for Public Comment Concerning Proposed Determination of Action Pursuant to Section 301: China's Acts, Policies, and Practices Related to Technology Transfer, Intellectual Property, and Innovation*, 83 Fed. Reg. 28,710 (U.S. Trade Rep. June 20, 2018).

³⁸ Chinese respondents' postconference brief, Attachment, p. 7.

³⁹ For example, some self-propelled aerial work platforms were excluded from October 2, 2019 to December 31, 2020. Petitioner's postconference brief ex. 1, pp. 43-44.

⁴⁰ End users include construction companies and other end users including rental companies, who may also act as retailers.

Table II-1**MAE: U.S. producers' and importers' U.S. shipments, by sources and channels of distribution, 2018-20**

Item	Calendar year		
	2018	2019	2020
	Share of U.S. shipments (percent)		
U.S. producers: to End users	***	***	***
to Distributors and retailers	***	***	***
U.S. importers: China to End users	***	***	***
to Distributors and retailers	***	***	***
U.S. importers: Nonsubject to End users	***	***	***
to Distributors and retailers	***	***	***
U.S. importers: All sources: to End users	***	***	***
to Distributors and retailers	***	***	***

Source: Compiled from data submitted in response to Commission questionnaires.

Geographic distribution

U.S. producers and importers reported selling MAE to all regions in the contiguous United States (table II-2). For U.S. producers, *** percent of sales were within 100 miles of their production facility, *** percent were between 101 and 1,000 miles, and *** percent were over 1,000 miles. Importers sold *** percent within 100 miles of their U.S. point of shipment, *** percent between 101 and 1,000 miles, and *** percent over 1,000 miles.

Table II-2**MAE: Geographic market areas in the United States served by U.S. producers and importers**

Region	U.S. producers	Subject U.S. importers
Northeast	6	9
Midwest	7	10
Southeast	6	10
Central Southwest	6	9
Mountains	6	8
Pacific Coast	6	10
Other	5	6
All regions (except Other)	6	7
Reporting firms	7	10

Note: All other U.S. markets, including AK, HI, PR, and VI.

Source: Compiled from data submitted in response to Commission questionnaires.

Supply and demand considerations

U.S. supply

Table II-3 provides a summary of the supply factors regarding MAE from U.S. producers and from China. As shown in the table below, Chinese capacity grew to outpace U.S. capacity from 2018-20.

Table II-3

MAE: Supply factors that affect the ability to increase shipments to the U.S. market

	Capacity (units)		Capacity utilization (percent)		Inventories as a ratio to total shipments (percent)		Shipments by market in (percent)		Able to shift to alternate products
	2018	2020	2018	2020	2018	2020	Home market shipments	Exports to non-U.S. markets	No. of firms reporting "yes"
United States	***	***	***	***	***	***	***	***	0 of 7
China	***	***	***	***	***	***	***	***	0 of 6

Note: Responding U.S. producers accounted for virtually all of U.S. production of MAE in 2020. Responding foreign producer/exporter firms accounted for less than 75 percent of U.S. imports of MAE from China during 2020. For additional data on the number of responding firms and their share of U.S. production and of U.S. imports from each subject country, please refer to Part I, "Summary Data and Data Sources."

Source: Compiled from data submitted in response to Commission questionnaires.

Domestic production

Based on available information, U.S. producers of MAE have the ability to respond to changes in demand with large changes in the quantity of shipments of U.S.-produced MAE to the U.S. market. The main contributing factors to this degree of responsiveness of supply are the availability of large amounts of unused capacity and some ability to shift shipments from alternate markets or inventories. Factors mitigating responsiveness of supply include the limited ability to shift production to or from alternate products.

U.S. producers' capacity decreased by *** percent while production decreased by *** percent. U.S. producer JLG noted that it also experienced production curtailments in 2019 and plant shutdowns occurring one week per month starting in late 2019 and increasing up to two weeks per month beginning in 2020. U.S. producer Terex closed its Rock Hill, South Carolina plant in December 2020.^{41 42} Capacity utilization declined from 2018-20, with less than

⁴¹ Conference transcript, p. 20 (Brightbill).

⁴² Other reported production constraints included raw materials, labor availability, machine capacity, product mix, parts availability, and weather.

30 percent capacity utilization by 2020. U.S. producers' major export markets include Australia, Canada, Central America, Europe, Japan, and South America.⁴³ U.S. producer JLG stated that the standard configuration for machines made for the Chinese, European, and U.S. market are "very similar."⁴⁴ No other products can be produced on the same equipment as MAE.⁴⁵

Subject imports from China

Based on available information, producers of MAE from China have the ability to respond to changes in demand with large changes in the quantity of shipments of MAE to the U.S. market. The main contributing factors to this degree of responsiveness of supply are the availability of unused capacity and inventories and the ability to shift shipments from alternate markets. Factors mitigating responsiveness of supply include the inability to shift production to or from alternate products.

Chinese capacity and production both increased from 2018-20, with capacity increasing by *** percent and production increasing by *** percent, resulting in a net decline in capacity utilization. Chinese producers reported exports to all major regions including Asia, Africa, Europe, the Middle East, North America, South America, and Oceania.⁴⁶ There were no reported barriers to exports. No Chinese producers reported producing other products on MAE equipment.⁴⁷

⁴³ U.S. producer JLG stated that its U.S. manufacturing facilities service the North and South American markets, its European facilities service Europe, and its Chinese facility for the Chinese and Asian Pacific markets. U.S. producer Terex similarly stated that its facilities in the United States, Europe, and China are made to service their respective markets. Conference transcript, pp. 50-51 (Meyer, Morris).

⁴⁴ Conference transcript, p. 98 (Morris).

⁴⁵ U.S. producers reported cost and the specific equipment and machinery as limiting factors in their inability to shift production to alternate products.

⁴⁶ Specifically, they reported exports to Australia, Chile, Germany, India, Italy, Japan, Korea, Malaysia, Mexico, New Zealand, Russia, South Africa, the Netherlands, and Turkey.

⁴⁷ Factors affecting foreign producers' inability to shift production include asset availability and cost. Chinese producer *** reported that it is unable to switch production (capacity) between MAE and other products using the same equipment and/or labor, but also noted that it produced vertical lifts on the same equipment, machinery or with the same employees as it used to produce MAE. *** reported that "the cost and time of shifting" as factors affecting its ability to shift production capacity between products.

Imports from nonsubject sources

Nonsubject imports accounted for *** percent of total U.S. imports in 2020. The two largest importers of nonsubject imports were *** which listed Mexico, Romania, France, and Italy, as their major sources of imports from nonsubject countries.⁴⁸

Supply constraints

U.S. producer *** reported that it had to allocate production amongst customers.⁴⁹ Three U.S. importers reported supply constraints.⁵⁰ *** reported that smaller rental firms were unable to order from U.S. manufacturers and *** reported that it does not supply all models.⁵¹

U.S. demand

Based on available information, the overall demand for MAE is likely to experience small to moderate changes in response to changes in price. The main contributing factor is the lack of substitute products, but is somewhat moderated by the ability of large customers to delay purchases in the short-term.

End uses and cost share

Fully assembled MAE is an end-use product and are not used in further downstream products. Reported end uses for fully assembled MAE include uses for equipment rental agencies and uses in the agriculture and construction sectors.

Business cycles

Six of seven U.S. producers and 11 of 16 importers indicated that the market was subject to business cycles or distinct conditions of competition. Specifically, U.S. producers *** and *** reported that the business cycle is seasonal and mirrors the construction industry. U.S. producer *** added that there are new competitors entering the U.S. market from China. Importer *** reported that sales to

⁴⁸ U.S. producers *** have affiliate firms that produce MAE in these nonsubject countries.

⁴⁹ U.S. producer *** reported that it had available capacity to meet additional demand, but it could not “get close enough to the prices of the Chinese-made MAE to obtain orders.”

⁵⁰ *** reported the same supply constraints reported in their U.S. producer questionnaires and are not included in the count.

⁵¹ Importer *** did not explain its supply constraint.

rental agencies are highest in the second quarter and lower in the fourth and first quarter.⁵² It also noted that the new ANSI standards resulted in “large-scale attempts” to offload pre-ANSI standard inventory, particularly among U.S. producers. Importer *** reported that the industry cycle is seven years, and the market is subject to seasonality, peaking in the second and third quarter.

Demand trends

Demand for MAE is generally tied to construction trends, particularly nonresidential construction. As shown in figure II-1, seasonally adjusted nonresidential construction spending fluctuated from 2018-20, and increased by 3.3 percent from January 2018 to December 2020. Construction spending rose throughout 2018 and 2019, peaked in January 2020 and began to decline in March 2020, associated with the economic slowdown due to the COVID-19 pandemic.⁵³

⁵² *** added that small to mid-size rental firms are “looking for quicker, flexible, and nimble supply that wasn't tied to large national rental houses. These smaller rental houses struggled for attention and machine availability from many U.S. manufacturers in 2019 when industry was high.” *** questionnaire response, III-16.

⁵³ The National Bureau of Economic Research (“NBER”) reported that the United States entered a recession in February 2020. “Determination of the February 2020 Peak in US Economic Activity,” NBER, (June 8, 2020), <https://www.nber.org/news/business-cycle-dating-committee-announcement-june-8-2020>.

Figure II-1

Nonresidential construction spending: Monthly, billions of dollars, seasonally adjusted annual rate, January 2018 to December 2020

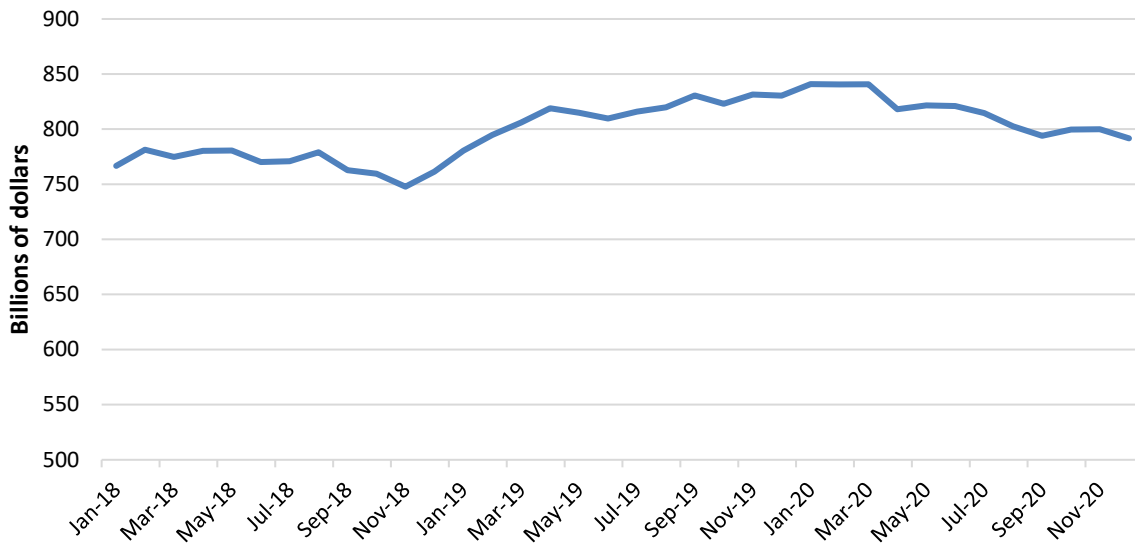

Source: U.S. Census Bureau, Total Construction Spending: Nonresidential (TLNRESCONS), retrieved from FRED, Federal Reserve Bank of St. Louis; <https://fred.stlouisfed.org/series/TLNRESCONS>, March 26, 2021.

Most U.S. producers reported that U.S. demand decreased or fluctuated,⁵⁴ and most importers reported a decrease in U.S. demand for MAE since January 1, 2018 (table II-4).

Table II-4

MAE: Firms’ responses regarding U.S. demand and demand outside the United States

Item	Number of firms reporting			
	Increase	No change	Decrease	Fluctuate
Demand inside the United States:				
U.S. producers	1	0	3	3
Importers	1	2	6	4
Demand outside the United States:				
U.S. producers	2	0	2	3
Importers	2	4	2	2

Source: Compiled from data submitted in response to Commission questionnaires.

Both petitioner and respondents noted that the COVID-19 pandemic impacted demand for MAE in 2020. U.S. producer JLG stated that while its facilities did not close due to the

⁵⁴ U.S. producers *** reported that demand fluctuated. *** was the only U.S. producer of the three to explain its response, reporting that the long-term market trajectory is of increasing demand, but this was interrupted in 2020 due to COVID and “economic activity primarily in the construction sector.”

pandemic, “many large construction projects” using JLG’s MAE were shut down.⁵⁵ Respondent Sinoboom argued that demand for MAE dropped “by over 60 percent” during the pandemic.⁵⁶ Respondent MEC added that there was a shift in demand for “dirt equipment” in 2019 due to an increase in U.S. infrastructure projects.⁵⁷

Substitute products

All responding U.S. producers (7) and importers (15) reported that there were no substitutes.

Substitutability issues

The degree of substitution between domestic and imported MAE depends upon such factors as relative prices, quality (e.g., grade standards, defect rates, etc.), and conditions of sale (e.g., price discounts/rebates, lead times between order and delivery dates, reliability of supply, product services, etc.). Based on available data, staff believes that there is a moderately high degree of substitutability between domestically produced MAE and MAE imported from China. Firms’ responses varied regarding the significance of differences other than price between MAE produced in the United States and China, as well as differing lead times due to the types of shipments (made-to-order versus shipments from inventory) limit the substitutability between domestic and Chinese MAE.

Lead times

U.S. producers reported that most of their commercial U.S. shipments were produced-to-order, while importers reported that their shipments were mainly from U.S. inventories. U.S. producers reported that *** percent of their commercial shipments were produced-to-order, with lead times averaging *** days. The remaining *** percent of their commercial shipments came from inventories, with lead times averaging *** days. Importers reported that *** percent of their shipments were from U.S. inventories, with lead times averaging *** days, *** percent were produced-to-order, with lead times of *** days, and the remaining *** percent of shipments were from foreign inventories with lead times of *** days.

Chinese respondents argued that differences in lead times between domestic and Chinese MAE were significant and were an important non-price factor in purchasers’

⁵⁵ Conference transcript, p. 35 (Morris).

⁵⁶ Conference transcript, p. 152 (Kirschenmann).

⁵⁷ Respondent MEC’s postconference brief, p. 12.

decisions.⁵⁸ Chinese respondents emphasized that smaller “mom and pop” companies have “immediate needs” that U.S. producers are unable to meet.⁵⁹

Factors affecting purchasing decisions

Purchasers responding to lost sales lost revenue allegations⁶⁰ were asked to identify the main purchasing factors their firm considered in their purchasing decisions for MAE. The major purchasing factors identified by *** were brand, country of origin, and price. It added that it only buys “top tier equipment” and will not buy “off brands.”

Comparison of U.S.-produced and imported MAE

In order to determine whether U.S.-produced MAE can generally be used in the same applications as imports from China, U.S. producers and importers were asked whether the products can always, frequently, sometimes, or never be used interchangeably. As shown in table II-5, all U.S. producers and the majority of importers reported that domestic and Chinese-made MAE are always interchangeable.⁶¹

Table II-5
MAE: Interchangeability between MAE produced in the United States and in other countries, by country pair

Country pair	U.S. producers				U.S. importers			
	A	F	S	N	A	F	S	N
United States vs. China	6	0	0	0	6	2	2	1
United States vs. Other	6	0	0	0	6	2	2	0
China vs. Other	6	0	0	0	5	1	1	0

Note: A=Always, F=Frequently, S=Sometimes, N=Never.

Source: Compiled from data submitted in response to Commission questionnaires.

Importer ***, which indicated that domestic and Chinese MAE are sometimes interchangeable, reported that quality and the ability to meet code limited interchangeability. Importer ***, which rated MAE as sometimes interchangeable between U.S. and Chinese MAE, reported that the customer may ask for adaptations but “generally these are commodity products.”

⁵⁸ Chinese respondents’ postconference brief, pp. 23-27.

⁵⁹ Chinese respondents’ postconference brief, pp. 25-27.

⁶⁰ This information is compiled from responses by purchasers identified by petitioner to the lost sales lost revenue allegations. Only one firm (***) responded to the lost sales and lost revenue survey. See Part V for additional information.

⁶¹ Importer *** reported that domestic and Chinese-made MAE are never interchangeable, adding that it “never produce{s} MAE in the United States.”

Petitioner argued that domestic and Chinese MAE are highly interchangeable to the point that Chinese firms have “intentionally copied U.S. producers’ products” and that U.S. producers have already sought legal avenues to protect their intellectual property.⁶² Chinese respondents disagreed, noting physical differences between the two sources of MAE, including that U.S. producers JLG and Terex can build booms higher than 125 feet, and respondent MEC stated that it provides MAE with a “micro footprint” and “launched a new product class” which U.S. producers have attempted to copy.⁶³

In addition, U.S. producers, and importers were asked to assess how often differences other than price were significant in sales of MAE from the United States, China, or nonsubject countries. As seen in table II-6, firms’ responses were mixed. Two U.S. producers reported that non-price factors were frequently important, two reported they were never, and one firm each reported non-price factors were always or sometimes important. Importers’ responses were also varied, with three firms each reporting that non-price factors were frequently, sometimes, or never important, and two firms reporting they were always important.

Table II-6
MAE: Significance of differences other than price between MAE produced in the United States and in other countries, by country pair

Country pair	U.S. producers				U.S. importers			
	A	F	S	N	A	F	S	N
United States vs. China	1	2	1	2	2	3	3	3
United States vs. Other	1	0	3	2	2	1	4	2
China vs. Other	1	2	1	2	2	2	1	2

Note: A = Always, F = Frequently, S = Sometimes, N = Never.

Source: Compiled from data submitted in response to Commission questionnaires.

U.S. producer ***, which reported that non-price factors are never important, reported that technical support should be a factor, but due to low prices customers have overlooked technical and aftersales support. Importers provided numerous responses regarding the significance of non-price differences between domestic and Chinese MAE. Most responses included quality, availability, and technical support as significant differences between domestic

⁶² U.S. producer JLG received a federal injunction against Chinese producer LGMG for using its orange and cream color scheme, and U.S. producer Terex has also sought an injunction against Chinese producer Sinoboom for using its colors. Petitioner’s postconference brief, p. 18.

⁶³ Conference transcript at 205 (Paylor); Respondent MEC’s postconference brief, pp. 5-6.

and Chinese MAE.^{64 65 66} Importer *** reported that unrelated to the country of origin, “today’s MAE lack safety, performance, durability and efficiency” that can be “easily accomplished by U.S. manufacturers yet they lack this level of innovation.”

⁶⁴ Importer *** noted that Chinese producer Dingli provides a “very high-quality scissor.” Importer *** reported that availability, quality, aftersales service, parts and training are important in the industry and that *** “patented innovations and safety features add to the value proposition” for its customers. *** reported that differences in non-price factors are always significant.

⁶⁵ Importer *** added that differences in quality, availability safety standards, product specifications and technical support were significant non-price factors between domestic and Chinese MAE. *** reported that differences in non-price factors are frequently significant.

⁶⁶ Importer *** listed supply availability, lead times, support, and parts availability as significant differences between domestic and Chinese MAE. *** reported that differences in non-price factors are sometimes significant.

Part III: U.S. producers' production, shipments, and employment

The Commission analyzes a number of factors in making injury determinations (see 19 U.S.C. §§ 1677(7)(B) and 1677(7)(C)). Information on the subsidies and dumping margins was presented in *Part I* of this report and information on the volume and pricing of imports of the subject merchandise is presented in *Part IV* and *Part V*. Information on the other factors specified is presented in this section and/or *Part VI* and (except as noted) is based on the questionnaire responses of seven firms that accounted for the vast majority of U.S. production of MAE during 2020.

U.S. producers

The Commission issued a U.S. producer questionnaire to 10 firms based on information contained in the petition and industry research. Seven firms provided usable data on their operations. Staff believes that these responses represent the vast majority of U.S. production of MAE.¹

Table III-1 lists U.S. producers of MAE, their production locations, positions on the petition, and shares of total production.

¹ The Commission sent a U.S. producer questionnaire to (1) Custom Equipment, (2) Haulotte, (3) JLG, (4) MEC, (5) Snorkel, and (6) Terex, each providing a useable response. The Commission also sent a questionnaire to Niftylift Inc. ("Nifty"), Pettibone Traverse Lift, LLC ("Pettibone"), Skyjack Inc. ("Skyjack"), and Teupen USA Inc ("Teupen"). *** responded that they were not U.S. producers of MAE. *** did not provide the Commission with a response. See correspondence with ***, EDIS # 737950.

The Commission received a seventh useable U.S. producer questionnaire from (7) Xtreme, who ***.

Table III-1

MAE: U.S. producers, their position on the petition, location of production, and share of reported production, 2020

Firm	Position on petition	Production location(s)	Share of production (percent)
Custom Equipment	***	Richfield, WI West Bend, WI	***
Haulotte	***	Archbold, Ohio	***
JLG	Petitioner	McConnellsburg, PA Shippensburg, PA Bedford, PA Greencastle, PA	***
MEC	***	Kerman, CA	***
Snorkel	***	Elwood, KS Henderson, NV	***
Terex	Petitioner	Redmond, WA Moses Lake, WA Oklahoma City, OK	***
Xtreme	***	Henderson, NV	***
Total			***

Source: Compiled from data submitted in response to Commission questionnaires.

Table III-2 presents information on U.S. producers' ownership, related and/or affiliated firms. In addition to being U.S. producers, six of the seven firms reported being a U.S. importer, as well as being related to a producer and/or importer/exporter of MAE.² *** is a subsidiary of ***, a manufacturer of MAE in ***, who also has MAE subsidiaries in ***. *** is related to MAE producers in ***. *** is owned in part by ***, a producer and an exporter of MAE from China to United States. *** is related to MAE producers in ***. *** owns in part ***, who is related to MAE producers in ***.³

² *** reported it had no related firms engaged in the manufacturing of MAE or engaged in the import/exportation of MAE between China and the United States.

³ For further information see the sections below on *U.S. producers' imports* and *U.S. producers' purchases*.

**Table III-2
MAE: U.S. producers' ownership, related and/or affiliated firms**

Item / Firm	Firm Name	Affiliated/Ownership
Ownership:		
***	***	***
***	***	***
***	***	***
***	***	***
***	***	***
***	***	***
***	***	***
***	***	***
***	***	***
***	***	***
***	***	***
***	***	***
***	***	***
***	***	***
***	***	***
***	***	***
***	***	***
***	***	***
***	***	***
***	***	***
***	***	***
***	***	***
***	***	***
***	***	***
***	***	***
***	***	***
***	***	***
***	***	***
***	***	***
***	***	***
***	***	***
***	***	***
***	***	***
***	***	***
***	***	***
***	***	***
***	***	***
***	***	***
***	***	***
***	***	***
***	***	***
***	***	***
***	***	***
***	***	***
***	***	***
***	***	***
***	***	***
***	***	***
***	***	***
***	***	***
***	***	***
***	***	***
***	***	***
***	***	***
***	***	***
***	***	***

Source: Compiled from data submitted in response to Commission questionnaires.

Table III-3 presents U.S. producers' reported changes in operations since January 1, 2018. Two firms, ***, reported plant openings. *** opened ***. *** opened ***. ***, however, also reported ***. *** likewise reported ***. Both *** reported *** in an effort to promote business efficiency.

The majority of firms reported *** as a result of the impact of the COVID-19 pandemic.⁴

Table III-3
MAE: U.S. producers' reported changes in operations, since January 1, 2018

Item / Firm	Reported changes in operations
Plant openings:	
***	***
***	***
Plant closings:	
***	***
***	***
Relocations:	
***	***
***	***
Consolidations:	
***	***

Table continued on next page.

⁴ For further information see the section below on the *Impact of the COVID-19 pandemic* on U.S. producers' operations.

Table III-3--Continued

MAE: U.S. producers' reported changes in operations, since January 1, 2018

Item / Firm	Reported changes in operations
Prolonged shutdowns or curtailments:	
***	***
***	***
***	***
***	***
***	***
***	***
Other:	
***	***

Source: Compiled from data submitted in response to Commission questionnaires.

Impact of the COVID-19 pandemic

In the current proceedings, U.S. producers were asked to discuss the impact of the COVID-19 pandemic on their firms' supply chain arrangements, production, shipments, and employment relating to MAE. Table III-4 presents U.S. producers' responses.

Several U.S. producers reported that they were not required to stop their operations as a result of the COVID-19 pandemic, as construction machinery manufacturers were deemed essential businesses by many local governments. However, lower demand for MAE by construction companies, whose projects were either delayed or terminated due to the pandemic, had a negative impact on U.S. producers. As U.S. producers lowered supply to meet decreasing demand, they were forced to reduce employee hours, issue furloughs, cut staff, and close plants for extended periods of time. Several U.S. producers, however, reported benefiting from the Small Business Administration's (SBA) Paycheck Protection Program (PPP), which provided loans to firms to continue paying their workers.

At the onset of the pandemic, U.S. producers were also hampered by supply chain issues. Due to the shutdown of many manufacturing plants around the world and the closure of some ports, there was a shortage of MAE parts in the global market. Without these parts to produce finished MAE, firms had an increasing number of order delays.

Table III-4
MAE: U.S. producers' responses to the impact of COVID-19 pandemic on their operations

Firm	Narrative
***	***
***	***
***	***
***	***
***	***
***	***

Source: Compiled from data submitted in response to Commission questionnaires

U.S. production, capacity, and capacity utilization

Table III-5 and figure III-1 present U.S. producers' production, capacity, and capacity utilization. Capacity decreased *** percent during the period of the investigations, from *** units in 2018 to *** units in 2020. The decrease in capacity is largely attributable to ***, which lost *** units in capacity during 2018-19.⁵

Production decreased by *** percent from 2018 to 2019 and continued to decline by *** percent from 2019 to 2020; overall decreasing by *** percent during 2018-20. All firms, except for one,⁶ reported reduced production during the period of the investigations.

Capacity utilization mirrored decreasing capacity and production. In 2018, capacity utilization was at *** percent and dropped subsequently to *** percent in 2019 and *** percent in 2020, for a total decline of *** percentage points during 2018-20.

⁵ *** reported ***.

⁶ *** reported ***.

Table III-5
MAE: U.S. producers' capacity, production, and capacity utilization, 2018-20

Item	Calendar year		
	2018	2019	2020
	Capacity (units)		
Custom Equipment	***	***	***
Haulotte	***	***	***
JLG	***	***	***
MEC	***	***	***
Snorkel	***	***	***
Terex	***	***	***
Xtreme	***	***	***
All firms	***	***	***
	Production (units)		
Custom Equipment	***	***	***
Haulotte	***	***	***
JLG	***	***	***
MEC	***	***	***
Snorkel	***	***	***
Terex	***	***	***
Xtreme	***	***	***
All firms	***	***	***
	Capacity utilization (percent)		
Custom Equipment	***	***	***
Haulotte	***	***	***
JLG	***	***	***
MEC	***	***	***
Snorkel	***	***	***
Terex	***	***	***
Xtreme	***	***	***
All firms	***	***	***
	Share of production (percent)		
Custom Equipment	***	***	***
Haulotte	***	***	***
JLG	***	***	***
MEC	***	***	***
Snorkel	***	***	***
Terex	***	***	***
Xtreme	***	***	***
All firms	***	***	***

Source: Compiled from data submitted in response to Commission questionnaires.

Figure III-1
MAE: U.S. producers' capacity, production, and capacity utilization, 2018-20

* * * * *

Source: Compiled from data submitted in response to Commission questionnaires.

Alternative products

One firm, ***, reported production of alternative products using the same equipment, machinery, or employees as used to produce MAE. *** reported the production of ***.⁷

Foreign trade zone

Two firms, ***, reported that they produce MAE in and/or admit MAE into a foreign trade zone (FTZ). *** reported ***. *** reported that ***. *** clarified that ***.

⁷ *** notes that “***.”
*** reported ***.

U.S. producers' U.S. shipments and exports

Table III-6 presents U.S. producers' U.S. shipments,⁸ export shipments, and total shipments. During 2018-20, on average *** percent of U.S. producers' shipments were to the U.S. market and *** percent were export shipments.⁹ Both U.S. shipments and export shipments declined during the period of the investigations. Combined, total shipments decreased from *** units in 2018 to *** units in 2020, or a decline of *** percent.

The unit value for U.S. shipments of MAE¹⁰ averaged \$*** per unit during 2018-20; whereas the unit value for export shipments of MAE averaged \$*** per unit during the same time period. The unit value for total shipments increased from \$*** per unit in 2018 to \$*** per unit in 2020, or an increase of *** percent.

⁸ In these proceedings, U.S. producers were asked to report their firm's U.S. shipments by two product types: (1) a "Finished MAE," meaning a complete, fully assembled MAE; and (2) a "Subassembly," meaning an in-scope component of an MAE as defined by the product scope, including chassis, booms, boom turntables, and scissor arms.

All seven U.S. producers reported U.S. shipments of finished MAE during 2018-20. None of the U.S. producers reported U.S. shipments of subassemblies during the same time period. According to JLG, there is no real market for subassemblies outside of taking those subassemblies to produce a finished MAE. Conference transcript, pp. 70-71 (Morris).

⁹ Export destinations include ***. *** accounted for ***.

¹⁰ In these proceedings, U.S. producers and U.S. importers were asked to provide information on the range of per gross unit value for the different MAE and subassembly types used and or sold by their firm since January 1, 2018. Appendix E presents the average unit value analysis.

Table III-6

MAE: U.S. producers' U.S. shipments, export shipments, and total shipments, 2018-20

Item	Calendar year		
	2018	2019	2020
	Quantity (units)		
U.S. shipments	***	***	***
Export shipments	***	***	***
Total shipments	***	***	***
	Value (1,000 dollars)		
U.S. shipments	***	***	***
Export shipments	***	***	***
Total shipments	***	***	***
	Unit value (dollars per unit)		
U.S. shipments	***	***	***
Export shipments	***	***	***
Total shipments	***	***	***
	Share of quantity (percent)		
U.S. shipments	***	***	***
Export shipments	***	***	***
Total shipments	***	***	***
	Share of value (percent)		
U.S. shipments	***	***	***
Export shipments	***	***	***
Total shipments	***	***	***

Source: Compiled from data submitted in response to Commission questionnaires.

U.S. producers' inventories

Table III-7 presents U.S. producers' end-of-period inventories and the ratio of these inventories to U.S. producers' production, U.S. shipments, and total shipments. U.S. producers' end-of-period inventories decreased from *** units in 2019 to *** units in 2020, or a decline of *** percent.¹¹ Conversely, the ratios of inventories to U.S. production and total shipments all increased during the same time period.

Table III-7
MAE: U.S. producers' inventories, 2018-20

Item	Calendar year		
	2018	2019	2020
	Quantity (units)		
U.S. producers' end-of-period inventories	***	***	***
	Ratio (percent)		
Ratio of inventories to.--			
U.S. production	***	***	***
U.S. shipments	***	***	***
Total shipments	***	***	***

Source: Compiled from data submitted in response to Commission questionnaires.

¹¹ *** accounted for ***. *** notes that ***. *** U.S. producer questionnaire response at question III-12b

U.S. producers' imports

Six of the seven U.S. producers¹² reported importing MAE from subject and/or nonsubject source during 2018-20. U.S. producers' imports of MAE and the reason for their importation are presented in tables III-8 through III-14.

Table III-8
MAE: U.S. producers' imports for *, 2018-20**

Item	Calendar year		
	2018	2019	2020
	Quantity (units)		
*** U.S. production	***	***	***
*** U.S. imports from.-- China	***	***	***
Nonsubject	***	***	***
All imports sources	***	***	***
	Ratio (percent)		
*** ratio to U.S. production of imports from.-- China	***	***	***
Nonsubject	***	***	***
All imports sources	***	***	***
Firm's reason for importing:			

Source: Compiled from data submitted in response to Commission questionnaires.

¹² *** was the only U.S. producer to report no imports of MAE during the period of these investigations.

Table III-9
MAE: U.S. producers' imports for *, 2018-20**

Item	Calendar year		
	2018	2019	2020
	Quantity (units)		
*** U.S. production	***	***	***
*** U.S. imports from.-- China	***	***	***
Nonsubject	***	***	***
All imports sources	***	***	***
	Ratio (percent)		
*** ratio to U.S. production of imports from.-- China	***	***	***
Nonsubject	***	***	***
All imports sources	***	***	***
Firm's reason for importing:			

Source: Compiled from data submitted in response to Commission questionnaires.

Table III-10
MAE: U.S. producers' imports for *, 2018-20**

Item	Calendar year		
	2018	2019	2020
	Quantity (units)		
*** U.S. production	***	***	***
*** U.S. imports from.-- China	***	***	***
Nonsubject	***	***	***
All imports sources	***	***	***
	Ratio (percent)		
*** ratio to U.S. production of imports from.-- China	***	***	***
Nonsubject	***	***	***
All imports sources	***	***	***
Firm's reason for importing:			

Source: Compiled from data submitted in response to Commission questionnaires.

Table III-11
MAE: U.S. producers' imports for *, 2018-20**

Item	Calendar year		
	2018	2019	2020
	Quantity (units)		
*** U.S. production	***	***	***
*** U.S. imports from.-- China	***	***	***
Nonsubject	***	***	***
All imports sources	***	***	***
	Ratio (percent)		
*** ratio to U.S. production of imports from.-- China	***	***	***
Nonsubject	***	***	***
All imports sources	***	***	***
Firm's reason for importing:			

Source: Compiled from data submitted in response to Commission questionnaires.

Table III-12
MAE: U.S. producers' imports for *, 2018-20**

Item	Calendar year		
	2018	2019	2020
	Quantity (units)		
*** U.S. production	***	***	***
*** U.S. imports from.-- China	***	***	***
Nonsubject	***	***	***
All imports sources	***	***	***
	Ratio (percent)		
*** ratio to U.S. production of imports from.-- China	***	***	***
Nonsubject	***	***	***
All imports sources	***	***	***
Firm's reason for importing:			

Source: Compiled from data submitted in response to Commission questionnaires.

Table III-13

MAE: U.S. producers' imports for *, 2018-20**

Item	Calendar year		
	2018	2019	2020
	Quantity (units)		
*** U.S. production	***	***	***
*** U.S. imports from.-- China	***	***	***
	Ratio (percent)		
*** ratio to U.S. production of imports from.-- China	***	***	***
Firm's reason for importing:			

Source: Compiled from data submitted in response to Commission questionnaires.

Table III-14
MAE: U.S. producers' imports for * and ***, 2018-20**

Item	Calendar year		
	2018	2019	2020
	Quantity (units)		
*** U.S. production	***	***	***
*** U.S. imports from.-- China	***	***	***
Nonsubject	***	***	***
All imports sources	***	***	***
	Ratio (percent)		
*** ratio to U.S. production of imports from.-- China	***	***	***
Nonsubject	***	***	***
All imports sources	***	***	***

Source: Compiled from data submitted in response to Commission questionnaires.

Note: *** are combined as ***. *** U.S. importer questionnaire, p. 5.

U.S. producers' purchases

Two firms, ***, reported purchases of MAE from domestic, subject and/or nonsubject sources.¹³ *** reported purchasing ***. *** stated that it ***.¹⁴ *** reported purchasing ***.¹⁵ *** stated that it "****".¹⁶

U.S. employment, wages, and productivity

Table III-15 shows U.S. producers' employment-related data. Generally, most employment related metrics declined during the period of these investigations. The number of production and related workers (PRWs), total hours worked, and wages paid fell by *** percent, *** percent, and *** percent, respectively. Hourly wages and, consequently, unit labor costs were the only two measures to increase. Hourly wages rose by \$*** and unit labor costs increased by *** percent during 2018-20.

Table III-15
MAE: U.S. producers' employment related data, 2018-20

Item	Calendar year		
	2018	2019	2020
Production and related workers (PRWs) (number)	***	***	***
Total hours worked (1,000 hours)	***	***	***
Hours worked per PRW (hours)	***	***	***
Wages paid (\$1,000)	***	***	***
Hourly wages (dollars per hour)	***	***	***
Productivity (units per 1,000 hours)	***	***	***
Unit labor costs (dollars per unit)	***	***	***

Source: Compiled from data submitted in response to Commission questionnaires.

¹³ During these proceedings, U.S. producers were asked to report purchases of finished MAE and subassemblies of MAE. *** U.S. producers reported purchases of finished MAE. ***, reported purchases of subassemblies.

¹⁴ *** U.S. producer questionnaire response at question II-12b.

¹⁵ *** reported ***.

¹⁶ *** U.S. producer questionnaire response at question II-12b.

Part IV: U.S. imports, apparent U.S. consumption, and market shares

U.S. importers

The Commission issued importer questionnaires to 59 firms believed to be importers of subject MAE, as well as to all U.S. producers of MAE.¹ Usable questionnaire responses were received from 15 companies,² representing an estimated *** percent of U.S. imports from China,³ *** percent of U.S. imports from nonsubject sources,⁴ and *** percent of U.S.

¹ The Commission issued questionnaires to those firms identified in the petition, along with a review of ***.

² Of the remaining 44 firms that did not submit an importer questionnaire:

- Twenty-six firms certified they have not imported MAE into the U.S. since January 1, 2018.
- Thirteen firms did not respond.
- One firm, ***, March 23-24, 2021. EDIS #738789 and #737928. ***. *** importer questionnaire response, question II-10.
- One firm, ***, confirmed it imports MAE from ***, but did not submit a questionnaire. Emails from *** EDIS #738790.
- One firm, ***, did not complete a questionnaire, but provided the quantities and values it imported during 2018-20 (***). Email from ***, March 17-18, 2021, EDIS #73753 and #738759.
- One firm, *** confirmed it imports MAE from *** but did not respond to staff follow up to submit a questionnaire. Email from ***, March 15, 2021. EDIS #738136
- One firm, ***, confirmed it imports *** but did not submit a questionnaire. Staff telephone interview with ***. EDIS #73835. However, it appears ***. *** importer questionnaire response, question II-5a.

³ Staff estimated import coverage based on finished units of MAE. Staff estimate a total of *** units of finished MAE were imported into the U.S. from China in 2020.

(continued...)

imports from all sources,⁵ in 2020, under HTS subheadings 8427.10, 8427.20, 8427.90, and 8431.20, all of which are “basket” categories. Table IV-1 lists all responding U.S. importers of MAE from China and other sources, their locations, and their shares of U.S. imports in 2020. As noted in footnote 2, Skyjack Inc. (“Skyjack Canada”), believed to be the largest source of MAE from nonsubject sources, did not submit an importer questionnaire, thus it is not presented in table IV-1.

(...continued)

⁴ Staff estimate *** units of finished MAE were imported from nonsubject sources in 2020. This estimate includes *** units reported in importer questionnaires, 2020 official import statistics for Canada (9,835 units), to serve as an estimate of imports from Skyjack Canada, and official import statistics for *** to serve as an estimate of imports from ***.

⁵ Staff estimate a total of *** units of finished MAE were imported into the U.S. in 2020. Adding 2020 U.S. shipments of finished MAE reported in U.S. producer questionnaires to this total, staff estimate total 2020 U.S. shipments of finished MAE (i.e., apparent consumption) to be *** units. According to ***, 2020 U.S. shipments of MAE totaled ***. Petition, pp. 2-3.

Table IV-1**MAE: U.S. importers, their headquarters, and share of total imports by source, 2020**

Firm	Headquarters	Share of imports by source (percent)		
		China	Nonsubject sources	All import sources
Ballymore	Coatesville, PA	***	***	***
Clark	West Fargo, ND	***	***	***
Dash	Round Rock, TX	***	***	***
Global	San Luis Obispo, CA	***	***	***
Haulotte	Virginia Beach, VA	***	***	***
JLG	Hagerstown, MD	***	***	***
LGMG NA	Chambersburg, PA	***	***	***
MEC	Kerman, CA	***	***	***
Noblelift NA	Des Plaines, IL	***	***	***
Sinoboom	Katy, TX	***	***	***
Skyjack Equipment	West Chicago, IL	***	***	***
Snorkel	Elwood, KS	***	***	***
Terex	Redmond, WA	***	***	***
XCMG	Las Vegas, NV	***	***	***
Xtreme	Henderson, NV	***	***	***
All firms		100.0	100.0	100.0

Source: Compiled from data submitted in response to Commission questionnaires.

U.S. imports

Table IV-2 and figure IV-1 present data for U.S. imports of MAE from China and nonsubject sources. U.S. imports from China and nonsubject sources both decreased by unit and value during 2018-20. Imports from China decreased by *** percent in units and *** percent in value, while imports from nonsubject sources decreased by *** percent in units and *** percent in value. Unit values of imports from China increased by *** percent during 2018-20,⁶ while unit values of imports from nonsubject sources increased by *** percent.

During 2018-20, imports from China as a share of total imports decreased by *** percentage points in quantity, but increased by *** percentage points in value. The ratio of U.S. imports from China to U.S. production decreased by *** percentage points during 2018-20, while the ratio of nonsubject imports to U.S. production increased by *** percentage points.

Seven of 15 importers reported that the COVID-19 pandemic had an impact on their importing operations. Five reported declining sales (***), five reported supply chain disruptions due to shipping delays or foreign producer shutdowns (***), and four reported employment changes such as layoffs, furloughs, and reduced hours (***).

⁶ This increase was largely driven by the increased unit values of ***. *** importer questionnaire response, question II-5c.

Table IV-2
MAE: U.S. imports, by source, 2018-20

Item	Calendar year		
	2018	2019	2020
	Quantity (units)		
U.S. imports from.-- China	***	***	***
Nonsubject sources	***	***	***
All import sources	***	***	***
	Value (1,000 dollars)		
U.S. imports from.-- China	***	***	***
Nonsubject sources	***	***	***
All import sources	***	***	***
	Unit value (dollars per unit)		
U.S. imports from.-- China	***	***	***
Nonsubject sources	***	***	***
All import sources	***	***	***
	Share of quantity (percent)		
U.S. imports from.-- China	***	***	***
Nonsubject sources	***	***	***
All import sources	100.0	100.0	100.0
	Share of value (percent)		
U.S. imports from.-- China	***	***	***
Nonsubject sources	***	***	***
All import sources	100.0	100.0	100.0
	Ratio to U.S. production		
U.S. imports from.-- China	***	***	***
Nonsubject sources	***	***	***
All import sources	***	***	***

Source: Compiled from data submitted in response to Commission questionnaires.

Figure IV-1
MAE: U.S. import quantities and average unit values, 2018-20

* * * * *

Source: Compiled from data submitted in response to Commission questionnaires.

Negligibility

The statute requires that an investigation be terminated without an injury determination if imports of the subject merchandise are found to be negligible.⁷ Negligible imports are generally defined in the Act, as amended, as imports from a country of merchandise corresponding to a domestic like product where such imports account for less than 3 percent of the volume of all such merchandise imported into the United States in the most recent 12-month period for which data are available that precedes the filing of the petition or the initiation of the investigation. However, if there are imports of such merchandise from a number of countries subject to investigations initiated on the same day that individually account for less than 3 percent of the total volume of the subject merchandise, and if the imports from those countries collectively account for more than 7 percent of the volume of all such merchandise imported into the United States during the applicable 12-month period, then imports from such countries are deemed not to be negligible.⁸ Imports from China accounted for *** percent of total U.S. imports of MAE by quantity during 2020.⁹

Table IV-3
MAE: U.S. imports, by source, 2018-20

Item	February 2020 through January 2021	
	Quantity (units)	Share quantity (percent)
U.S. imports from.-- China	***	***
Nonsubject sources	***	***
All import sources	***	100.0

Source: Compiled from data submitted in response to Commission questionnaires.

⁷ Sections 703(a)(1), 705(b)(1), 733(a)(1), and 735(b)(1) of the Act (19 U.S.C. §§ 1671b(a)(1), 1671d(b)(1), 1673b(a)(1), and 1673d(b)(1)).

⁸ Section 771 (24) of the Act (19 U.S.C § 1677(24)).

⁹ Imports from China would account for *** percent of total imports with the addition of 2020 official import statistics under the relevant HTS codes for Canada (9,835 units) and *** to the nonsubject total in table IV-3, as an estimate of import volumes for Skyjack Canada and ***.

Apparent U.S. consumption

Table IV-4 and figure IV-2 present data on apparent U.S. consumption and U.S. market shares for MAE. U.S. producers' U.S. shipments, U.S. importers' U.S. shipments from China, and U.S. importers' U.S. shipments from nonsubject sources all decreased by unit and value during 2018-20. U.S. producers' U.S. shipments decreased *** percent in units and *** percent in value, U.S. importers' U.S. shipments from China decreased *** percent in units and *** percent in value, and U.S. importers' U.S. shipments from nonsubject sources decreased *** percent in units and *** percent in value.

U.S. shipments of imports from China as a share of total shipments decreased in units (** percentage points), but increased by value (** percentage points) during 2018-20, while U.S. producers' U.S. shipments as a share of total shipments increased in units (** percentage points), but decreased by value (** percentage points). U.S. shipments of imports from nonsubject sources as a share of total shipments increased in units (** percentage points) and value (** percentage points).

Table IV-4
MAE: Apparent U.S. consumption and market shares, 2018-20

Item	Calendar year		
	2018	2019	2020
	Quantity (units)		
U.S. producers' U.S. shipments	***	***	***
U.S. importers' U.S. shipments from.-- China	***	***	***
Nonsubject sources	***	***	***
All import sources	***	***	***
Apparent U.S. consumption	***	***	***
	Quantity (short tons)		
U.S. producers' U.S. shipments	***	***	***
U.S. importers' U.S. shipments from.-- China	***	***	***
Nonsubject sources	***	***	***
All import sources	***	***	***
Apparent U.S. consumption	***	***	***
	Value (1,000 dollars)		
U.S. producers' U.S. shipments	***	***	***
U.S. importers' U.S. shipments from.-- China	***	***	***
Nonsubject sources	***	***	***
All import sources	***	***	***
Apparent U.S. consumption	***	***	***
	Share of quantity based on units (percent)		
U.S. producers' U.S. shipments	***	***	***
U.S. importers' U.S. shipments from.-- China	***	***	***
Nonsubject sources	***	***	***
All import sources	***	***	***
	Share of quantity based on short tons (percent)		
U.S. producers' U.S. shipments	***	***	***
U.S. importers' U.S. shipments from.-- China	***	***	***
Nonsubject sources	***	***	***
All import sources	***	***	***
	Share of value (percent)		
U.S. producers' U.S. shipments	***	***	***
U.S. importers' U.S. shipments from.-- China	***	***	***
Nonsubject sources	***	***	***
All import sources	***	***	***

Source: Compiled from data submitted in response to Commission questionnaires.

Figure IV-2
MAE: Apparent U.S. consumption , 2018-20

* * * * *

Source: Compiled from data submitted in response to Commission questionnaires.

Complete MAE: U.S. imports and U.S. producers' U.S. shipments

Table IV-5 presents data on U.S. producers' U.S. shipments and U.S. importers' U.S. imports of complete MAE, which, combined, decreased by *** percent in units and *** percent in value, during 2018-20. U.S. producers' U.S. shipments of complete MAE decreased *** percent in units and *** percent in value during 2018-20. U.S. imports of complete MAE from China decreased *** percent in units and *** percent in value from 2018-20, while U.S. imports of complete MAE from nonsubject sources decreased *** percent in units and *** percent in value during this period.

During 2018-20, the share of U.S. imports of complete MAE from China increased by units (*** percentage points) and value (*** percentage points), while the share of U.S. producers' U.S. shipments of complete MAE decreased by units (*** percentage points) and value (*** percentage points). The share of U.S. imports of complete MAE from nonsubject sources decreased by units (*** percentage points) and value (*** percentage points).

During 2018-20, U.S. producers' U.S. shipments of complete MAE had the highest range of unit values (\$*** to \$***), followed by U.S. imports of complete MAE from nonsubject sources (\$*** to \$***). U.S. imports of complete MAE from China had the lowest range of unit values (\$*** to \$***).¹⁰ U.S. producers' U.S. shipments of complete MAE also had the highest average weight per unit, at nearly four times the average short tons per unit than U.S. imports from China. The average weight per unit for nonsubject imports was also substantially greater than the average weight per unit for subject imports (*** compared to *** for subject imports).

¹⁰ ** of 15 importers that accounted for *** percent of 2020 imports reported scissor lifts (with AUVs ranging from \$*** to \$***) as their highest volume product, while U.S. producers *** and ***, which together account for *** percent of 2020 U.S. production, reported boom lifts (with an AUV of \$***) and telehandlers (with an AUV of \$***), respectively, as their highest volume product. See Appendix E for more data on AUV ranges of complete and subassembly MAE products, as reported by U.S. importers and U.S. producers.

Table IV-5
Complete MAE: U.S. producers' U.S. shipments and U.S. importers' U.S. imports of complete MAE,
2018-20

Item	Calendar year		
	2018	2019	2020
	Quantity (units)		
U.S. producers' U.S. shipments	***	***	***
U.S. importers' U.S. imports from.-- China	***	***	***
Nonsubject sources	***	***	***
All import sources	***	***	***
All sources	***	***	***
	Quantity (short tons)		
U.S. producers' U.S. shipments	***	***	***
U.S. importers' U.S. imports from.-- China	***	***	***
Nonsubject sources	***	***	***
All import sources	***	***	***
All sources	***	***	***
	Value (1,000 dollars)		
U.S. producers' U.S. shipments	***	***	***
U.S. importers' U.S. imports from.-- China	***	***	***
Nonsubject sources	***	***	***
All import sources	***	***	***
All sources	***	***	***
	Unit value (dollars per unit)		
U.S. producers' U.S. shipments	***	***	***
U.S. importers' U.S. imports from.-- China	***	***	***
Nonsubject sources	***	***	***
All import sources	***	***	***
All sources	***	***	***
	Unit value (dollars per short ton)		
U.S. producers' U.S. shipments	***	***	***
U.S. importers' U.S. imports from.-- China	***	***	***
Nonsubject sources	***	***	***
All import sources	***	***	***
All sources	***	***	***
	Ratio (short tons per unit)		
U.S. producers' U.S. shipments	***	***	***
U.S. importers' U.S. imports from.-- China	***	***	***
Nonsubject sources	***	***	***
All import sources	***	***	***
All sources	***	***	***

Table continued on next page.

Table IV-5--Continued
Complete MAE: U.S. producers' U.S. shipments and U.S. importers' U.S. imports of complete MAE, 2018-20

Item	Calendar year		
	2018	2019	2020
	Share of quantity based on units (percent)		
U.S. producers' U.S. shipments	***	***	***
U.S. importers' U.S. imports from.-- China	***	***	***
Nonsubject sources	***	***	***
All import sources	***	***	***
All sources	***	***	***
	Share of quantity based on short tons (percent)		
U.S. producers' U.S. shipments	***	***	***
U.S. importers' U.S. imports from.-- China	***	***	***
Nonsubject sources	***	***	***
All import sources	***	***	***
All sources	***	***	***
	Share of value (percent)		
U.S. producers' U.S. shipments	***	***	***
U.S. importers' U.S. imports from.-- China	***	***	***
Nonsubject sources	***	***	***
All import sources	***	***	***
All sources	***	***	***
	Ratio to overall apparent consumption quantity in units (percent)		
U.S. producers' U.S. shipments	***	***	***
U.S. importers' U.S. imports from.-- China	***	***	***
Nonsubject sources	***	***	***
All import sources	***	***	***
All sources	***	***	***
	Ratio to overall apparent consumption value (percent)		
U.S. producers' U.S. shipments	***	***	***
U.S. importers' U.S. imports from.-- China	***	***	***
Nonsubject sources	***	***	***
All import sources	***	***	***
All sources	***	***	***

Source: Compiled from data submitted in response to Commission questionnaires.

MAE subassemblies: U.S. imports and U.S. producers' U.S. shipments

Table IV-6 and figure IV-3 present data on U.S. producers' U.S. shipments and U.S. importers' U.S. imports of MAE subassemblies during 2018-20. *** U.S. shipments of subassemblies were reported by U.S. producers. U.S. shipments of subassemblies from China decreased during 2018-20 by *** percent by quantity (units) and *** percent by value.¹¹ U.S. shipments of subassemblies from nonsubject sources decreased during 2018-20 by *** percent by quantity (units) and *** percent by value.¹² Unit values of subassembly imports from China increased by *** percent¹³ during 2018-20.

The share of subassembly imports from China decreased from *** percent of total subassembly imports, by value, in 2018 to *** percent in 2020. The value of total subassembly imports accounted for less than one percent of apparent consumption value throughout the period for which data were collected.

¹¹ *** U.S. importers that reported U.S. shipments of subassemblies from China (***) reported decreased U.S. shipments of subassemblies, by quantity and value, during 2018-19 and 2019-20.

¹² *** reported increased U.S. shipments of subassemblies from nonsubject sources during 2018-20, while the other *** U.S. importers (***) that reported U.S. shipments of subassemblies from nonsubject sources reported decreased U.S. shipments.

¹³ This increase was largely driven by the increased unit values of ***. *** importer questionnaire response, question II-5c.

Table IV-6
MAE subassemblies: U.S. producers' U.S. shipments and U.S. importers' U.S. imports of
subassemblies, 2018-20

Item	Calendar year		
	2018	2019	2020
	Quantity (units)		
U.S. producers' U.S. shipments	***	***	***
U.S. importers' U.S. imports from.-- China	***	***	***
Nonsubject sources	***	***	***
All import sources	***	***	***
All sources	***	***	***
	Quantity (short tons)		
U.S. producers' U.S. shipments	***	***	***
U.S. importers' U.S. imports from.-- China	***	***	***
Nonsubject sources	***	***	***
All import sources	***	***	***
All sources	***	***	***
	Value (1,000 dollars)		
U.S. producers' U.S. shipments	***	***	***
U.S. importers' U.S. imports from.-- China	***	***	***
Nonsubject sources	***	***	***
All import sources	***	***	***
All sources	***	***	***
	Unit value (dollars per unit)		
U.S. producers' U.S. shipments	***	***	***
U.S. importers' U.S. imports from.-- China	***	***	***
Nonsubject sources	***	***	***
All import sources	***	***	***
All sources	***	***	***
	Unit value (dollars per short ton)		
U.S. producers' U.S. shipments	***	***	***
U.S. importers' imports from.-- China	***	***	***
Nonsubject sources	***	***	***
All import sources	***	***	***
All sources	***	***	***
	Ratio (short tons per unit)		
U.S. producers' U.S. shipments	***	***	***
U.S. importers' U.S. imports from.-- China	***	***	***
Nonsubject sources	***	***	***
All import sources	***	***	***
All sources	***	***	***

Table continued on next page.

Table IV-6--Continued
MAE subassemblies: U.S. producers' U.S. shipments and U.S. importers' U.S. imports of
subassemblies, 2018-20

Item	Calendar year		
	2018	2019	2020
	Share of quantity based on units (percent)		
U.S. producers' U.S. shipments	***	***	***
U.S. importers' U.S. imports from.-- China	***	***	***
Nonsubject sources	***	***	***
All import sources	***	***	***
All sources	***	***	***
	Share of quantity based on short tons (percent)		
U.S. producers' U.S. shipments	***	***	***
U.S. importers' U.S. imports from.-- China	***	***	***
Nonsubject sources	***	***	***
All import sources	***	***	***
All sources	***	***	***
	Share of value (percent)		
U.S. producers' U.S. shipments	***	***	***
U.S. importers' U.S. imports from.-- China	***	***	***
Nonsubject sources	***	***	***
All import sources	***	***	***
All sources	***	***	***
	Ratio to overall apparent consumption quantity in units (percent)		
U.S. producers' U.S. shipments	***	***	***
U.S. importers' U.S. imports from.-- China	***	***	***
Nonsubject sources	***	***	***
All import sources	***	***	***
All sources	***	***	***
	Ratio to overall apparent consumption value (percent)		
U.S. producers' U.S. shipments	***	***	***
U.S. importers' U.S. imports from.-- China	***	***	***
Nonsubject sources	***	***	***
All import sources	***	***	***
All sources	***	***	***

Source: Compiled from data submitted in response to Commission questionnaires.

Figure IV-3

MAE: U.S. producers' U.S. shipments and U.S. importers' U.S. imports by product type, 2020

* * * * *

Source: Tables IV-5 and IV-6.

U.S. shipments of subassemblies, by end use

Table IV-7 presents data on U.S. producers' and U.S. importers' share of U.S. shipments of subassemblies, by end use. The vast majority of subassemblies are used by OEM manufacturers (***) to produce complete units of MAE. ***, reported importing subassemblies that would be used to refurbish existing MAE.

Table IV-7

MAE: U.S. producers' U.S. shipments and U.S. importers' U.S. imports of subassemblies, 2018-20

	Producers	China	Nonsubject
Subassemblies.-- For OEM manufacturing	***	***	***
For refurbishing	***	***	***
All end uses	***	100.0	100.0

Source: Compiled from data submitted in response to Commission questionnaires.

Part V: Pricing data

Factors affecting prices

Raw material costs

MAE is made predominantly of steel and fabricated steel parts. MAE is engine-powered or electric-powered, with mobile lifting devices, among other parts.¹ Major components of MAE may include frames, chassis, boom sections, and turntable assemblies which include engines, batteries, tanks, pumps, and other hydraulic components.^{2 3} Fabricated steel components comprised the largest share of raw material costs per MAE at *** percent in 2020, followed by hydraulic components (*** percent); engines, axles and transmissions (*** percent); other material inputs (*** percent); electrical or battery components (*** percent); and steel plate/sheet (*** percent).

U.S. producers use varying grades and thicknesses of hot-rolled plate and hot-rolled coil to produce MAE, as well as a limited amount of steel tubes or bars and cold-rolled steel.⁴ Prices of hot-rolled coil increased overall by *** percent and prices of cut-to-length plate increased by *** percent from 2018-20. Hot-rolled coil and cut-to-length plate prices increased in 2018 in conjunction with the steel 201 tariffs, and declined steadily throughout 2019 to August 2020, when prices then sharply increased and have continued to increase throughout 2021 (figures V-1 and V-2).^{5 6} Petitioner added that prices for other raw materials, such as *** also increased in 2020.⁷

¹ Petition, p. 8.

² Petition, p. 13.

³ Major subassemblies include: scissor arm assemblies or scissor arm sections, boom assemblies or boom sections, MAE chassis assemblies, boom turntable assemblies. Petition, pp. 11-13.

⁴ Petitioner's postconference brief, exh. 1 pp. 39-41.

⁵ Petitioner also noted that the prices of fabricated steel components used for MAE production vary by component, and that "prices of fabricated steel components purchased by domestic producers are driven in part by the cost of raw steel." Petitioner's postconference brief, exh. 1 pp. 39-42, *see also* Petitioner's postconference brief, exh. 21, and exh. 25.

⁶ No U.S. producer explained the reason for the increase in steel prices that occurred in July 2020 beyond market conditions.

⁷ Petitioner's postconference brief, exh. 1 p. 42.

Figure V-1

Steel hot-rolled coil: Carbon grade, f.o.b. U.S. mill average mid-price, dollars per short ton, January 2018-February 2021

* * * * *

Source: ***, retrieved March 29, 2021.

Figure V-2

Steel cut-to-length plate: Carbon grade, f.o.b. U.S. mill average mid-price, dollars per short ton, January 2018-February 2021

* * * * *

Source: ***, retrieved March 29, 2021.

Raw materials as a share of cost of goods sold (“COGS”) fluctuated over the period but decreased overall. The share of raw materials increased from *** percent in 2018 to ***

percent in 2019 before decreasing to *** percent in 2020. Six of seven responding U.S. producers reported that raw material prices had increased, with some firms noting that steel prices fluctuated since 2018.⁸

Transportation costs to the U.S. market

Transportation costs for MAE shipped from China to the United States averaged 7.1 percent for China during 2020. These estimates were derived from official import data and represent the transportation and other charges on imports.⁹

U.S. inland transportation costs

All seven responding U.S. producers and 11 of 13 responding importers reported that they typically arrange transportation to their customers. Most U.S. producers reported that their U.S. inland transportation costs ranged from 2.5 to 6.5 percent while most importers reported costs of 2.0 to 8.0 percent.

Pricing practices

Pricing methods

As discussed in Part II, purchasers of MAE are segregated by the four largest national equipment rental firms (“consolidators”),¹⁰ regional rental firms, and local “mom and pop” equipment rental firms. Respondents argued that sales to these consolidators differ from sales to smaller firms, and that the national firms require “extensive negotiations, contracts, low prices, and tremendous aftermarket support.”¹¹ Respondent MEC stated that it ***

⁸ U.S. producers JLG, Haulotte, MEC, Snorkel, Terex, and Xtreme provided U.S. producer and U.S. importer questionnaire responses. These responses are reported separately throughout this section, unless otherwise indicated.

⁹ The estimated transportation costs were obtained by subtracting the customs value from the c.i.f. value of the imports for 2020 and then dividing by the customs value based on the HTS subheading 8427.10.8020, 8427.10.8030, 8427.10.8070, 8427.10.8095, 8427.20.8020, 8427.20.8090, and 8431.20.0000 and may include out-of-scope product.

¹⁰ Respondents stated that there has been consolidation among the largest national equipment rental firms: “These very large and extremely well financed companies began to buy up multiple regional independent stores and consolidate them” in the late 1990s. Conference transcript, p. 142 (Paylor) and respondent MEC’s postconference brief pp. 10-11.

¹¹ Conference transcript, p. 151.

***.^{12 13} Petitioner stated that there are no significant differences in sales terms for different customers.¹⁴

U.S. producers and importers reported setting prices using set price lists, transaction-by-transaction negotiations, and contracts (table V-1).¹⁵

Table V-1
MAE: U.S. producers' and importers' reported price setting methods, by number of responding firms

Method	U.S. producers	U.S. importers
Transaction-by-transaction	4	8
Contract	4	6
Set price list	5	10
Other	1	1
Responding firms	7	13

Note: The sum of responses down may not add up to the total number of responding firms as each firm was instructed to check all applicable price setting methods employed.

Source: Compiled from data submitted in response to Commission questionnaires.

U.S. producers and importers reported selling MAE with a mix of annual contracts, short-term contracts, and spot sales. U.S. producers reported selling its 2020 shipments through an almost equal mix of short-term contracts, annual contracts, and spot sales. Importers reported selling a larger share of their 2020 shipments through annual contracts and spot sales, a smaller amount through short-term contracts, and virtually no sales through long-term contracts (table V-2).

¹² Respondent MEC's postconference brief, p. 11.

¹³ As discussed in Part II, firms may also trade in old MAE as a form of discounting new MAE in price negotiations. Respondent MEC stated that the consolidators include trade ins as part of the contract negotiation, and that in order to participate in advance purchase orders with the consolidators, the firm is required to take a certain amount of consolidators' used MAE on trade for disposal, which can be sold into the secondary market. Conference transcript, pp. 200-202 (Paylor, Kirschenmann, Hix).

¹⁴ Conference transcript, pp. 104-105 (Meyer, Morris).

¹⁵ Multiple firms reported using more than one way to set prices.

Table V-2**MAE: U.S. producers' and importers' shares of U.S. commercial shipments by type of sale, 2020**

Item	U.S. producers	Subject U.S. importers
Share (percent)		
Share of commercial U.S. shipments.--		
Long-term contracts	***	***
Annual contract	***	***
Short-term contracts	***	***
Spot sales	***	***

Note: Because of rounding, figures may not add to the totals shown.

Source: Compiled from data submitted in response to Commission questionnaires.

Five U.S. producers reported using short-term contracts to set prices, with an average of 30 to 180 days.¹⁶ Most (4 of 5) short-term contracts did not allow for price renegotiation and had a fixed price and quantity provision. Four U.S. producers reported using annual contracts to set prices, two firms allowed for price renegotiations, two did not. Most U.S. producers' annual contracts had a fixed price. No contracts were indexed to raw material prices.

Six importers reported setting prices through short-term contracts with the average duration ranging from 30 to 180 days. Most short-term contracts did not allow for price renegotiations (3 of 5) and either had a fixed price (2 of 5) or fixed price and quantity provision (3 of 5). Four importers reported setting prices through annual contracts with price renegotiations (3 of 4) and fixed price (4 of 4). No contracts were indexed to raw material prices.

Sales terms and discounts

U.S. producers and importers typically quote prices on an f.o.b. basis. U.S. producers offer the following discounts: total volume (6 of 7), quantity (5), no policy (2), and other discounts (1).¹⁷ U.S. producer *** reported that its discount quantities and annual discounts are set on a "case-by-case" basis, with quantity discounts determined on "truckload" quantities, and annual discounts are determined by annual spending and are locked in during first quarter promotions. *** reported that volume discounts are structured as rebates or committed annual volumes, and transaction discounts are for committed quantities per order.

¹⁶ U.S. producer *** was the only U.S. producer to report a long-term contract, with an average duration of 2 years.

¹⁷ Multiple firms reported more than one type of discount policy.

Importers reported offering discounts based on total volume (8 of 13), quantity (7), other factors (4), or no policy (3).¹⁸ Importer *** reported that its “other” discounts are based on size. Importer *** reported that “below-floor prices” may be considered for large-volume sales, and rebates are determined based on quarterly merchandising and sales strategies. Importer *** “other” discount is the retail price with a set multiplier discount.

U.S. producer Terex provides ***. Chinese respondents stated that customers can trade-in old MAE for a discount on new MAE.¹⁹

Warranties are also a part of MAE sales and are “fairly standardized” across the industry. Petitioner argued that warranties offered with domestic MAE are similar to those for Chinese MAE.²⁰

Price data

The Commission requested U.S. producers and importers to provide quarterly data for the total quantity and f.o.b. value of the following MAE products shipped to unrelated U.S. customers during January 2018-December 2020.²¹

Product 1.-- Battery-powered scissor lift, with electric or hydraulic drive, with 18’-20’ platform height elevation and 500 lb. to 600 lb. maximum lift capacity

¹⁸ Multiple firms reported more than one discount policy.

¹⁹ Chinese respondents’ postconference brief, pp. 36-37.

²⁰ U.S. producer ***. U.S. producer ***. U.S. producer and importer ***. Importer *** offers ***. Lastly, importer ***. As noted in Part II, the life cycle of most MAE is 4-8 years. Petitioner’s postconference brief, exh. 1 p. 52.

²¹ As discussed in Part II, new ANSI standards were put into effect in June 2020. Petitioner argued that new ANSI standards had a “modest effect on pricing in the U.S. market” and are incorporated in products 1-3. Respondents argued that the price data is “skewed” as it includes products made to the old and new ANSI standards. Respondents also stated that the ANSI standards impact products 1-4. See Petitioner’s postconference brief, exh. 1 pp. 47-48, and Chinese respondents’ postconference brief, p. 35.

Product 2.-- Diesel-powered four- or all-wheel drive articulating boom lift, with 44'-46' platform height elevation and 500 lb. to 1000 lb. maximum lift capacity

Product 3.-- Diesel-powered four- or all-wheel drive telescoping boom lift, with 64'-67' platform height elevation including jib option and 500 lb. to 1000 lb. maximum lift capacity

Product 4.-- Diesel-powered four- or all-wheel drive material telehandler, with 53'-57' maximum lift height and 10,000-lb. maximum lift capacity

Two U.S. producers²² and nine importers²³ provided usable pricing data for sales of the requested products, although not all firms reported pricing for all products for all quarters.^{24 25} No importer reported usable pricing data for product 4. Pricing data reported by these firms accounted for *** percent of U.S. producers' shipments of MAE and *** percent of U.S. shipments of subject imports from China in 2020.²⁶

Price data for products 1-4 are presented in tables V-3 to V-6 and figures V-1 to V-4.

²² The following U.S. producers provided unusable price data: *** provided price data for products that were outside the definition of pricing product 1, *** reported average net sales for pricing products 1-3, and *** reported the "average selling price" for product 4. These firms' price data have not been included in the tables and figures below.

²³ Importer *** reported that it used its average cost for pricing product 1; its price data have not been included in the tables and figures below.

²⁴ Per-unit pricing data are calculated from total quantity and total value data provided by U.S. producers and importers. The precision and variation of these figures may be affected by rounding, limited quantities, and producer or importer estimates.

²⁵ Petitioner argued that the price data are "of limited value" as it alleged importer ***.

²⁶ Pricing coverage is based on U.S. shipments reported in questionnaires.

Table V-3

MAE: Weighted-average f.o.b. prices and quantities of domestic and imported product 1 and margins of underselling/(overselling), by quarter, January 2018-December 2020

Period	United States		China		
	Price (dollars per unit)	Quantity (units)	Price (dollars per unit)	Quantity (units)	Margin (percent)
2018:					
Jan.-Mar.	***	***	***	***	***
Apr.-Jun.	***	***	***	***	***
Jul.-Sep.	***	***	***	***	***
Oct.-Dec.	***	***	***	***	***
2019:					
Jan.-Mar.	***	***	***	***	***
Apr.-Jun.	***	***	***	***	***
Jul.-Sep.	***	***	***	***	***
Oct.-Dec.	***	***	***	***	***
2020:					
Jan.-Mar.	***	***	***	***	***
Apr.-Jun.	***	***	***	***	***
Jul.-Sep.	***	***	***	***	***
Oct.-Dec.	***	***	***	***	***

Note: Product 1: Battery-powered scissor lift, with electric or hydraulic drive, with 18'-20' platform height elevation and 500 lb. to 600 lb. maximum lift capacity

Source: Compiled from data submitted in response to Commission questionnaires.

Table V-4

MAE: Weighted-average f.o.b. prices and quantities of domestic and imported product 2 and margins of underselling/(overselling), by quarter, January 2018-December 2020

Period	United States		China		
	Price (dollars per unit)	Quantity (units)	Price (dollars per unit)	Quantity (units)	Margin (percent)
2018:					
Jan.-Mar.	***	***	***	***	***
Apr.-Jun.	***	***	***	***	***
Jul.-Sep.	***	***	***	***	***
Oct.-Dec.	***	***	***	***	***
2019:					
Jan.-Mar.	***	***	***	***	***
Apr.-Jun.	***	***	***	***	***
Jul.-Sep.	***	***	***	***	***
Oct.-Dec.	***	***	***	***	***
2020:					
Jan.-Mar.	***	***	***	***	***
Apr.-Jun.	***	***	***	***	***
Jul.-Sep.	***	***	***	***	***
Oct.-Dec.	***	***	***	***	***

Note: Product 2: Diesel-powered four- or all-wheel drive articulating boom lift, with 44'-46' platform height elevation and 500 lb. to 1000 lb. maximum lift capacity.

Source: Compiled from data submitted in response to Commission questionnaires.

Table V-5

MAE: Weighted-average f.o.b. prices and quantities of domestic and imported product 3 and margins of underselling/(overselling), by quarter, January 2018-December 2020

Period	United States		China		
	Price (dollars per unit)	Quantity (units)	Price (dollars per unit)	Quantity (units)	Margin (percent)
2018:					
Jan.-Mar.	***	***	***	***	***
Apr.-Jun.	***	***	***	***	***
Jul.-Sep.	***	***	***	***	***
Oct.-Dec.	***	***	***	***	***
2019:					
Jan.-Mar.	***	***	***	***	***
Apr.-Jun.	***	***	***	***	***
Jul.-Sep.	***	***	***	***	***
Oct.-Dec.	***	***	***	***	***
2020:					
Jan.-Mar.	***	***	***	***	***
Apr.-Jun.	***	***	***	***	***
Jul.-Sep.	***	***	***	***	***
Oct.-Dec.	***	***	***	***	***

Note: Product 3: Diesel-powered four- or all-wheel drive telescoping boom lift, with 64'-67' platform height elevation including jib option and 500 lb. to 1000 lb. maximum lift capacity.

Source: Compiled from data submitted in response to Commission questionnaires.

Table V-6

MAE: Weighted-average f.o.b. prices and quantities of domestic product 4 and margins of underselling/(overselling), by quarter, January 2018-December 2020

Period	United States	
	Price (dollars per unit)	Quantity (units)
2018:		
Jan.-Mar.	***	***
Apr.-Jun.	***	***
Jul.-Sep.	***	***
Oct.-Dec.	***	***
2019:		
Jan.-Mar.	***	***
Apr.-Jun.	***	***
Jul.-Sep.	***	***
Oct.-Dec.	***	***
2020:		
Jan.-Mar.	***	***
Apr.-Jun.	***	***
Jul.-Sep.	***	***
Oct.-Dec.	***	***

Note: Product 4: Diesel-powered four- or all-wheel drive material telehandler, with 53'-57' maximum lift height and 10,000-lb. maximum lift capacity.

Source: Compiled from data submitted in response to Commission questionnaires.

Figure V-1
MAE: Weighted-average prices and quantities of domestic and imported product 1, by quarter, January 2018-December 2020

* * * * *

* * * * *

Product 1: Battery-powered scissor lift, with electric or hydraulic drive, with 18'-20' platform height elevation and 500 lb. to 600 lb. maximum lift capacity.

Source: Compiled from data submitted in response to Commission questionnaires.

Figure V-2

MAE: Weighted-average prices and quantities of domestic and imported product 2, by quarter, January 2018-December 2020

* * * * *

* * * * *

Product 2: Diesel-powered four- or all-wheel drive articulating boom lift, with 44'-46' platform height elevation and 500 lb. to 1000 lb. maximum lift capacity.

Source: Compiled from data submitted in response to Commission questionnaires.

Figure V-3
MAE: Weighted-average prices and quantities of domestic and imported product 3, by quarter, January 2018-December 2020

* * * * *

* * * * *

Product 3: Diesel-powered four- or all-wheel drive telescoping boom lift, with 64'-67' platform height elevation including jib option and 500 lb. to 1000 lb. maximum lift capacity.

Source: Compiled from data submitted in response to Commission questionnaires.

Figure V-4
MAE: Weighted-average prices and quantities of domestic and imported product 4, by quarter, January 2018-December 2020

* * * * *

* * * * *

Product 4: Diesel-powered four- or all-wheel drive material telehandler, with 53'-57' maximum lift height and 10,000-lb. maximum lift capacity.

Source: Compiled from data submitted in response to Commission questionnaires.

Price trends

In general, prices increased during 2018-20. Table V-7 summarizes the price trends, by country and by product. As shown in the table, domestic price increases ranged from *** to *** percent during January 2018-December 2020 while import price increases ranged from *** to *** percent. Prices for product 2 imported from China decreased by *** percent, and no importer reported price data for product 4.

Table V-7

MAE: Summary of weighted-average f.o.b. prices for products 1-4 from the United States and China

Item	Number of quarters	Low price (dollars per unit)	High price (dollars per unit)	Change in price over period ¹ (percent)
Product 1: United States	***	***	***	***
China	***	***	***	***
Product 2: United States	***	***	***	***
China	***	***	***	***
Product 3: United States	***	***	***	***
China	***	***	***	***
Product 4: United States	***	***	***	***
China	***	***	***	***

Note: Percentage change from the first quarter in which data were available to the last quarter in which price data were available.

Source: Compiled from data submitted in response to Commission questionnaires.

Indexed prices of U.S. producers' price data shows that prices remained relatively stable and increased slightly throughout the period, and were higher at the end of the period. Indexed prices of importers' price data shows larger price variation in product 3, which was a smaller volume product, with prices that increased throughout the period before steadily falling near the end of the period. Importers' prices for products 1-2 had less variability but moved in opposite directions, with prices of product 1 increasing steadily throughout the period and prices of product 2 slightly decreasing through June 2020.

Figure V-5

MAE: Indexed U.S. producer prices, January 2018 through December 2020

* * * * *

Source: Compiled from data submitted in response to Commission questionnaires.

Figure V-6

MAE: Indexed subject U.S. importer prices, January 2018 through December 2020

* * * * *

Source: Compiled from data submitted in response to Commission questionnaires.

Price comparisons

As shown in table V-8, prices for product imported from China were below those for U.S.-produced product in 14 of 34 instances (***) units); margins of underselling ranged from *** to *** percent. In the remaining 20 instances (***) units), prices for product from China were between *** and *** percent above prices for the domestic product.

Table V-8

MAE: Instances of underselling/overselling and the range and average of margins, by product and by year, January 2018 through December 2020

Source	Underselling				
	Number of quarters	Quantity (units)	Average margin (percent)	Margin range (percent)	
				Min	Max
Product 1	***	***	***	***	***
Product 2	***	***	***	***	***
Product 3	***	***	***	***	***
Product 4	---	---	---	---	---
Total, underselling	14	***	4.5	0.1	13.1
2018	***	***	***	***	***
2019	***	***	***	***	***
2020	***	***	***	***	***
Total, underselling	14	***	4.5	0.1	13.1
Source	(Overselling)				
	Number of quarters	Quantity (units)	Average margin (percent)	Margin range (percent)	
				Min	Max
Product 1	***	***	***	***	***
Product 2	***	***	***	***	***
Product 3	***	***	***	***	***
Product 4	---	---	---	---	---
Total, overselling	20	***	(7.0)	(0.6)	(22.8)
2018	***	***	***	***	***
2019	***	***	***	***	***
2020	***	***	***	***	***
Total, overselling	20	***	(7.0)	(0.6)	(22.8)

Note: These data include only quarters in which there is a comparison between the U.S. and subject product. No importers reported price data for product 4.

Source: Compiled from data submitted in response to Commission questionnaires.

Lost sales and lost revenue

The Commission requested that U.S. producers of MAE report purchasers with which they experienced instances of lost sales or revenue due to competition from imports of MAE from China during 2018-2020. Of the seven responding U.S. producers, three reported that they had to either reduce prices or roll back announced price increases, and three firms reported

that they had lost sales. Two U.S. producers submitted lost sales and lost revenue allegations. The two responding U.S. producers identified 20 firms with which they lost sales or revenue (14 consisting of lost sales allegations, 4 consisting of lost revenue allegations, and 2 consisting of both types of allegations). Virtually all the allegations occurred in ***, with one occurring in *** and one in ***; allegations totaled *** units and *** dollars.

Staff contacted 20 purchasers²⁷ and received a response from 1 purchaser, ***.²⁸ It reported purchasing *** units of MAE during 2018-20, of which *** were domestic MAE and *** units were from nonsubject sources ***. *** increased its share of purchases from domestic sources by *** percent and increased its volume of purchases from domestic sources, citing greater construction demand in Texas. It reported that it had not purchased Chinese MAE instead of domestic MAE, and that it did not know if U.S. producers had reduced prices due to competition from Chinese MAE.

Petitioner identified other instances of lost sales and lost revenue, arguing that Chinese firms price their MAE price below U.S. producers' cost of production.²⁹

²⁷ In addition to three emails sent to each purchaser, staff called numerous purchasers to encourage their participation. See staff telephone notes, March 16, 2021.

²⁸ Purchaser *** responded to the lost sales and lost revenue survey and indicated that it did not purchase any MAE since 2018.

²⁹ Petitioner's postconference brief, pp. 27-30.

Part VI: Financial experience of U.S. producers

Background

The U.S.-produced MAE financial results of five firms (***) are presented in this section of the report, covering the period January 1, 2018 through December 31, 2020.¹ All firms except *** reported their financial results on the basis of U.S. generally accepted accounting principles (GAAP) and for calendar-year periods.² *** combined accounted for *** percent of the period's total reported sales quantity: *** (***) percent) and *** (***) percent. The remaining firms accounted for shares ranging from *** percent of the period's total sales quantity (***) to *** percent (***). The majority of MAE revenue reflects commercial sales, but also includes a minimal share of transfer sales.³ No internal consumption was reported. Given the predominance of commercial sales throughout the period, a single revenue line item is presented in the tables below.

Operations on MAE

Table VI-1 and table VI-2 present income-and-loss data for U.S. producers' MAE operations and corresponding changes in average per MAE values (AUVs), respectively. Table VI-3 presents selected company-specific financial information.

¹ *** submitted incomplete U.S. producer questionnaires in the financial section and their partial responses are not included in the aggregated financial data. These companies accounted for *** percent of total shipments in 2020. ***.

² ***, however its financial results were provided on a calendar year basis.

³ ***. Email from ***, March 24, 2021.

Table VI-1
MAE: Results of operations of U.S. producers, 2018-20

Item	Calendar year		
	2018	2019	2020
	Quantity (units)		
Total net sales	***	***	***
	Value (1,000 dollars)		
Total net sales	***	***	***
Cost of goods sold.--			
Raw materials	***	***	***
Direct labor	***	***	***
Other factory costs	***	***	***
Total COGS	***	***	***
Gross profit	***	***	***
SG&A expense	***	***	***
Operating income or (loss)	***	***	***
All other expense/(income), net	***	***	***
Net income or (loss)	***	***	***
Depreciation/amortization	***	***	***
Cash flow	***	***	***
	Ratio to net sales (percent)		
Cost of goods sold.--			
Raw materials	***	***	***
Direct labor	***	***	***
Other factory costs	***	***	***
Average COGS	***	***	***
Gross profit	***	***	***
SG&A expense	***	***	***
Operating income or (loss)	***	***	***
Net income or (loss)	***	***	***
	Ratio to total COGS (percent)		
Cost of goods sold.--			
Raw materials	***	***	***
Direct labor	***	***	***
Other factory costs	***	***	***
Average COGS	***	***	***

Table continued on next page.

Table VI-1--Continued
MAE: Results of operations of U.S. producers, 2018-20

Item	Calendar year		
	2018	2019	2020
	Unit value (dollars per MAE)		
Total net sales	***	***	***
Cost of goods sold.-- Raw materials	***	***	***
Direct labor	***	***	***
Other factory costs	***	***	***
Average COGS	***	***	***
Gross profit	***	***	***
SG&A expense	***	***	***
Operating income or (loss)	***	***	***
Net income or (loss)	***	***	***
	Number of firms reporting		
Operating losses	***	***	***
Net losses	***	***	***
Data	***	***	***

Source: Compiled from data submitted in response to Commission questionnaires.

Table VI-2
MAE: Changes in AUVs, between calendar years, 2018-20

Item	Between calendar years		
	2018-20	2018-19	2019-20
	Change in AUVs (percent)		
Total net sales	***	***	***
Cost of goods sold.-- Raw materials	***	***	***
Direct labor	***	***	***
Other factory costs	***	***	***
Average COGS	***	***	***
	Change in AUVs (dollars per MAE)		
Total net sales	***	***	***
Cost of goods sold.-- Raw materials	***	***	***
Direct labor	***	***	***
Other factory costs	***	***	***
Average COGS	***	***	***
Gross profit	***	***	***
SG&A expense	***	***	***
Operating income or (loss)	***	***	***
Net income or (loss)	***	***	***

Source: Compiled from data submitted in response to Commission questionnaires.

Table VI-3

MAE: Results of operations of U.S. producers, by firm, 2018-20

Item	Calendar year		
	2018	2019	2020
	Total net sales (units)		
***	***	***	***
***	***	***	***
***	***	***	***
***	***	***	***
***	***	***	***
All firms	***	***	***
	Total net sales (1,000 dollars)		
***	***	***	***
***	***	***	***
***	***	***	***
***	***	***	***
***	***	***	***
All firms	***	***	***
	Cost of goods sold (1,000 dollars)		
***	***	***	***
***	***	***	***
***	***	***	***
***	***	***	***
***	***	***	***
All firms	***	***	***
	Gross profit or (loss) (1,000 dollars)		
***	***	***	***
***	***	***	***
***	***	***	***
***	***	***	***
***	***	***	***
All firms	***	***	***
	SG&A expenses (1,000 dollars)		
***	***	***	***
***	***	***	***
***	***	***	***
***	***	***	***
***	***	***	***
All firms	***	***	***

Table continued on next page.

Table VI-3--Continued

MAE: Results of operations of U.S. producers, by firm, 2018-20

Item	Calendar year		
	2018	2019	2020
	Operating income or (loss) (1,000 dollars)		
***	***	***	***
***	***	***	***
***	***	***	***
***	***	***	***
***	***	***	***
All firms	***	***	***
	Net income or (loss) (1,000 dollars)		
***	***	***	***
***	***	***	***
***	***	***	***
***	***	***	***
***	***	***	***
All firms	***	***	***
	COGS to net sales ratio (percent)		
***	***	***	***
***	***	***	***
***	***	***	***
***	***	***	***
***	***	***	***
All firms	***	***	***
	Gross profit or (loss) to net sales ratio (percent)		
***	***	***	***
***	***	***	***
***	***	***	***
***	***	***	***
***	***	***	***
All firms	***	***	***
	SG&A expense to net sales ratio (percent)		
***	***	***	***
***	***	***	***
***	***	***	***
***	***	***	***
***	***	***	***
All firms	***	***	***

Table continued on next page.

Table VI-3--Continued

MAE: Results of operations of U.S. producers, by firm, 2018-20

Item	Calendar year		
	2018	2019	2020
	Operating income or (loss) to net sales ratio (percent)		
***	***	***	***
***	***	***	***
***	***	***	***
***	***	***	***
***	***	***	***
All firms	***	***	***
	Net income or (loss) to net sales ratio (percent)		
***	***	***	***
***	***	***	***
***	***	***	***
***	***	***	***
***	***	***	***
All firms	***	***	***
	Unit net sales value (dollars per MAE)		
***	***	***	***
***	***	***	***
***	***	***	***
***	***	***	***
***	***	***	***
All firms	***	***	***
	Unit raw materials (dollars per MAE)		
***	***	***	***
***	***	***	***
***	***	***	***
***	***	***	***
***	***	***	***
All firms	***	***	***
	Unit direct labor (dollars per MAE)		
***	***	***	***
***	***	***	***
***	***	***	***
***	***	***	***
***	***	***	***
All firms	***	***	***

Table continued on next page.

Table VI-3--Continued

MAE: Results of operations of U.S. producers, by firm, 2018-20

Item	Calendar year		
	2018	2019	2020
	Unit other factory costs (dollars per MAE)		
***	***	***	***
***	***	***	***
***	***	***	***
***	***	***	***
***	***	***	***
All firms	***	***	***
	Unit COGS (dollars per MAE)		
***	***	***	***
***	***	***	***
***	***	***	***
***	***	***	***
***	***	***	***
All firms	***	***	***
	Unit gross profit or (loss) (dollars per MAE)		
***	***	***	***
***	***	***	***
***	***	***	***
***	***	***	***
***	***	***	***
All firms	***	***	***
	Unit SG&A expenses (dollars per MAE)		
***	***	***	***
***	***	***	***
***	***	***	***
***	***	***	***
***	***	***	***
All firms	***	***	***
	Unit operating income or (loss) (dollars per MAE)		
***	***	***	***
***	***	***	***
***	***	***	***
***	***	***	***
***	***	***	***
All firms	***	***	***

Table continued on next page.

Table VI-3--Continued

MAE: Results of operations of U.S. producers, by firm, 2018-20

Item	Calendar year		
	2018	2019	2020
	Unit net income or (loss) (dollars per MAE)		
***	***	***	***
***	***	***	***
***	***	***	***
***	***	***	***
***	***	***	***
All firms	***	***	***

Source: Compiled from data submitted in response to Commission questionnaires.

Net Sales

The U.S. industry’s total net sales by quantity and value declined by *** percent and *** percent from 2018 to 2019, then further declined by *** percent and *** percent from 2019 to 2020, respectively. The net sales quantity and value of *** U.S. producers declined overall from 2018 to 2020.⁴

On an overall basis, average sales value per MAE increased to its highest level in 2019 and then declined somewhat in 2020, resulting in an increase of *** percent from 2018 to 2020. As shown in table VI-3, the relatively wide range of company-specific average sales values reflects basic differences. ***.⁵

⁴ *** Email from ***, March 30, 2021. ***. Email from ***, March 31, 2021.

⁵ ***. Email from ***, March 16, 2021. ***. Email from ***, March 24, 2021. ***. Email from ***, March 18, 2021.

All U.S. producers except *** reported an overall increase in sales value per MAE from 2018 to 2020. ***.

Cost of goods sold and gross profit or loss

Raw materials

Total raw material cost is the largest component of cost of goods sold (COGS), ranging from *** percent (2020) of total COGS to *** percent (2019). On an average per MAE basis, the U.S. industry’s raw material cost increased from 2018 to 2019, then declined in 2020, resulting in an increase from 2018 to 2020. On a company-specific basis, all U.S. producers except *** reported an overall increase in average raw material costs per MAE from 2018 to 2020.⁶ Raw materials consist of steel plate/sheet, other fabricated steel components, engines, axles, transmissions, electrical/battery components, hydraulic components, and other material inputs such as ***. Table VI-4 presents a break-out of the raw material costs, by type, for calendar year 2020.

Table VI-4
MAE: Raw material costs, by type, 2020

Raw materials	Calendar 2020	
	Value (1,000 dollars)	Share of value (percent)
Steel plate/sheet	***	***
Other fabricated steel components	***	***
Engines, axles, transmissions	***	***
Electrical and/or battery components	***	***
Hydraulic components	***	***
Other material inputs	***	***
Total, raw materials	***	***

Source: Compiled from data submitted in response to Commission questionnaires.

⁶ ***. Email from ***, March 24, 2021. ***. Email from ***, March 24, 2021.

Table VI-5 presents data on subassemblies U.S producers reported in raw materials which were purchased or imported for MAE production.^{7 ***} ⁸

Table VI-5
MAE: Subassembly purchased/imported included in raw materials, by firm, 2018-20

Item	Calendar year		
	2018	2019	2020
	Value (1,000 dollars)		
***	***	***	***
***	***	***	***
***	***	***	***
***	***	***	***
All firms	***	***	***
	Ratio to total raw materials (percent)		
***	***	***	***
***	***	***	***
***	***	***	***
***	***	***	***
All firms	***	***	***
	Subassembly		Source
***	***		***
***	***		***
***	***		***
***	***		***

Source: Compiled from data submitted in response to staff's request. Emails from ***, March 24, 2021.

⁷ ***. Petitioners' postconference brief, exh. 1, p. 36. ***, April 2, 2021.

⁸ Email from ***, March 24, 2021.

Direct labor and other factory costs

Direct labor, the smallest component of COGS, ranged from *** percent (2019) to *** percent (2018 and 2020). On an average per MAE basis, direct labor cost increased from 2018 to 2020. On a company-specific basis, *** U.S. producers reported overall increasing direct labor costs from 2018 to 2020. The range of average direct labor cost between companies, however, was relatively wide with *** reporting the *** average direct labor cost and *** reporting the *** average direct labor cost throughout the reporting period.⁹

Other factory costs, the second largest component of COGS, ranged from *** percent (2019) of total COGS to *** percent (2020). The U.S. industry's average per MAE other factory costs declined marginally from 2018 to 2019 and then increased in 2020. Other factory costs include both variable and fixed components. The period of investigation's lowest sales quantity was reported in 2020 which was the same year when the industry reported the highest other factory costs per MAE because fixed costs included in other factory costs were allocated over fewer sales units. On a company-specific basis, *** U.S. producers reported overall increasing other factory costs per MAE from 2018 to 2020.

COGS and gross profit or loss

The average COGS to net sales ratio declined somewhat from *** percent in 2018 to *** percent in 2019, then increased to *** percent in 2020 largely due to increased other factory costs as a ratio to net sales.

As shown in table VI-1, the industry's gross profit declined from 2018 to 2020 because the decline in net sales value along with the decline in sales volume from 2018 to 2020 exceeded the corresponding decline in COGS. Gross margin (gross profit as a ratio to net sales) somewhat increased from *** percent in 2018 to *** percent in 2019, then declined to *** percent in 2020. On a company-specific basis, all U.S. producers except *** reported overall declining gross profit and gross profit margins from 2018 to 2020.

⁹ ***. Email from ***, March 24, 2021.

SG&A expenses and operating income or loss

The U.S. industry's total selling, general, and administrative (SG&A) expenses declined from 2018 to 2020. In conjunction with declines in total sales value, SG&A expense ratios (total SG&A expenses divided by total sales value) increased throughout the period because fixed costs included in SG&A expenses were allocated over fewer sales units. Table VI-3 shows that *** U.S. producers reported an overall increasing SG&A expense ratio from 2018 to 2020.¹⁰

Operating income and the operating income margin (operating income as a ratio to net sales) declined from 2018 to 2020 with the greatest decline in 2020, largely reflecting the aforementioned decline in total gross profit. On a company-specific basis, *** U.S. producers reported overall declining operating income and operating income margins. ***.¹¹

Interest expense, other expenses and income, and net income or loss

Classified below the operating income level are interest expense, other expense, and other income. In table VI-1, these items are aggregated and only the net amount is shown. The industry's net "all other expenses" increased from 2018 to 2019, then declined in 2020. *** accounted for the vast majority of reported net "all other expenses" during the reporting period.

Net income declined from 2018 to 2019 and further declined to a loss in 2020. The net income margin (net income as a ratio to net sales) exhibited the same trend. On a company-specific basis, *** U.S. producers reported overall declining net income and net income margins. ***.

¹⁰ ***. Email from ***, March 31, 2021. ***. Email from ***, March 30, 2021.

¹¹ Due to the relatively wide range of company-specific average per MAE sales values, as well as some changes in company-specific product mix during the period (see *Net Sales* section), a variance analysis is not presented in this section of the report.

Table VI-6 presents the U.S. producers' narrative responses regarding effects on financial performance of COVID-19.

Table VI-6
MAE: Firms' narrative responses relating to COVID-19 pandemic effects on U.S. producers' financial performance

Item / Firm	Narrative
***	***
***	***
***	***
***	***
***	***

Source: Compiled from data submitted in response to Commission questionnaires.

Capital expenditures and research and development expenses

Table VI-7 presents U.S. producers' capital expenditures and research and development (R&D) expenses related to their MAE operations and table VI-8 presents firm-specific narrative descriptions.

Table VI-7

MAE: Total capital expenditures and research and development (R&D) expenses of U.S. producers, 2018-20

Item	Calendar year		
	2018	2019	2020
	Capital expenditures (1,000 dollars)		
All firms	***	***	***
R&D expenses (1,000 dollars)			
All firms	***	***	***

Source: Compiled from data submitted in response to Commission questionnaires.

Table VI-8

MAE: Narrative descriptions of U.S. producers' capital expenditures and R&D expenses since January 1, 2018

Item / Firm	Narrative
Nature and focus of capital expenditures	
***	***
***	***
***	***
***	***
***	***
Nature and focus of R&D expenses	
***	***
***	***
***	***
***	***
***	***

Source: Compiled from data submitted in response to Commission questionnaires.

Assets and return on assets

Table VI-9 presents U.S. producers' total net assets and operating return on net assets related to operations on MAE.¹²

Table VI-9

MAE: Value of assets used in production, warehousing, and sales, and operating return on assets for U.S. producers by firm, 2018-20

Firm	Calendar years ended		
	2018	2019	2020
	Total net assets (1,000 dollars)		
All firms	***	***	***
	Operating return on assets (percent)		
All firms	***	***	***

Source: Compiled from data submitted in response to Commission questionnaires.

¹² With respect to a company's overall operations, staff notes that a total asset value (i.e., the bottom line value on the asset side of a company's balance sheet) reflects an aggregation of a number of current and non-current assets, which, in many instances, are not product specific. In at least some instances, allocation factors were presumably necessary to report total asset values specific to U.S. producers' MAE operations. The ability of U.S. producers to assign total asset values to discrete product lines affects the meaningfulness of operating return on net assets.

Capital and investment

The Commission requested the U.S. producers of MAE to describe any actual or potential negative effects on their return on investment or their growth, investment, ability to raise capital, existing development and production efforts, or the scale of capital investments as a result of imports of MAE from China. Table VI-10 tabulates the responses regarding actual negative effects on investment, growth, and development, as well as anticipated negative effects. Table VI-11 presents the narrative responses of U.S. producers regarding actual and anticipated negative effects on investment, growth, and development.

Table VI-10

MAE: Negative effects of imports from subject sources on investment, growth, and development since January 1, 2018

Item	No	Yes
Negative effects on investment	2	3
Cancellation, postponement, or rejection of expansion projects		1
Denial or rejection of investment proposal		0
Reduction in the size of capital investments		3
Return on specific investments negatively impacted		1
Other		2
Negative effects on growth and development	2	3
Rejection of bank loans		0
Lowering of credit rating		0
Problem related to the issue of stocks or bonds		0
Ability to service debt		1
Other		2
Anticipated negative effects of imports	1	4

Note: ***.

Source: Compiled from data submitted in response to Commission questionnaires.

Table VI-11

MAE: Narrative responses of U.S. producers regarding actual and anticipated negative effects of imports from subject sources on investment, growth, and development since January 1, 2018

Item / Firm	Narrative
Cancellation, postponement, or rejection of expansion projects:	
***	***
Reduction in the size of capital investments:	
***	***
***	***
***	***
Return on specific investments negatively impacted:	
***	***
Other negative effects on investments:	
***	***
***	***
Ability to service debt:	
***	***
Other effects on growth and development:	
***	***
***	***

Table continued on next page.

Table VI-11--Continued

MAE: Narrative responses of U.S. producers regarding actual and anticipated negative effects of imports from subject sources on investment, growth, and development since January 1, 2018

Anticipated effects of imports:	
***	***
***	***
***	***
***	***

Source: Compiled from data submitted in response to Commission questionnaires.

Part VII: Threat considerations and information on nonsubject countries

Section 771(7)(F)(i) of the Act (19 U.S.C. § 1677(7)(F)(i)) provides that—

In determining whether an industry in the United States is threatened with material injury by reason of imports (or sales for importation) of the subject merchandise, the Commission shall consider, among other relevant economic factors¹--

- (I) if a countervailable subsidy is involved, such information as may be presented to it by the administering authority as to the nature of the subsidy (particularly as to whether the countervailable subsidy is a subsidy described in Article 3 or 6.1 of the Subsidies Agreement), and whether imports of the subject merchandise are likely to increase,*
- (II) any existing unused production capacity or imminent, substantial increase in production capacity in the exporting country indicating the likelihood of substantially increased imports of the subject merchandise into the United States, taking into account the availability of other export markets to absorb any additional exports,*
- (III) a significant rate of increase of the volume or market penetration of imports of the subject merchandise indicating the likelihood of substantially increased imports,*
- (IV) whether imports of the subject merchandise are entering at prices that are likely to have a significant depressing or suppressing effect on domestic prices, and are likely to increase demand for further imports,*
- (V) inventories of the subject merchandise,*

¹ Section 771(7)(F)(ii) of the Act (19 U.S.C. § 1677(7)(F)(ii)) provides that “The Commission shall consider {these factors} . . . as a whole in making a determination of whether further dumped or subsidized imports are imminent and whether material injury by reason of imports would occur unless an order is issued or a suspension agreement is accepted under this title. The presence or absence of any factor which the Commission is required to consider . . . shall not necessarily give decisive guidance with respect to the determination. Such a determination may not be made on the basis of mere conjecture or supposition.”

- (VI) *the potential for product-shifting if production facilities in the foreign country, which can be used to produce the subject merchandise, are currently being used to produce other products,*
- (VII) *in any investigation under this title which involves imports of both a raw agricultural product (within the meaning of paragraph (4)(E)(iv)) and any product processed from such raw agricultural product, the likelihood that there will be increased imports, by reason of product shifting, if there is an affirmative determination by the Commission under section 705(b)(1) or 735(b)(1) with respect to either the raw agricultural product or the processed agricultural product (but not both),*
- (VIII) *the actual and potential negative effects on the existing development and production efforts of the domestic industry, including efforts to develop a derivative or more advanced version of the domestic like product, and*
- (IX) *any other demonstrable adverse trends that indicate the probability that there is likely to be material injury by reason of imports (or sale for importation) of the subject merchandise (whether or not it is actually being imported at the time).²*

Information on the nature of the subsidies was presented earlier in this report; information on the volume and pricing of imports of the subject merchandise is presented in *Parts IV* and *V*; and information on the effects of imports of the subject merchandise on U.S. producers' existing development and production efforts is presented in *Part VI*. Information on inventories of the subject merchandise; foreign producers' operations, including the potential for "product-shifting;" any other threat indicators, if applicable; and any dumping in third-country markets, follows. Also presented in this section of the report is information obtained for consideration by the Commission on nonsubject countries.

² Section 771(7)(F)(iii) of the Act (19 U.S.C. § 1677(7)(F)(iii)) further provides that, in antidumping investigations, ". . . the Commission shall consider whether dumping in the markets of foreign countries (as evidenced by dumping findings or antidumping remedies in other WTO member markets against the same class or kind of merchandise manufactured or exported by the same party as under investigation) suggests a threat of material injury to the domestic industry."

The industry in China

The Commission issued foreign producers' or exporters' questionnaires to 18 firms believed to produce and/or export MAE from China.³ Usable responses to the Commission's questionnaire were received from six firms: Oshkosh – JLG Equipment Technology Co. Ltd. (“JLG Tianjin”);⁴ Terex (Changzhou) Machinery Co. Ltd. (“Terex Changzhou”); Lingong Group Jinan Heavy Machinery Co., Ltd. (“Lingong”); Zhejiang Dingli Machinery Co., Ltd. (“Dingli”); Mantall Heavy Industry Co., Ltd. (“Mantall”); and Hunan Sinoboom Intelligent Equipment Co., Ltd. (“Hunan Sinoboom”). These firms' exports to the United States accounted for approximately *** percent of U.S. imports of MAE from China in 2020, as reported in importer questionnaires. According to estimates requested of the responding Chinese producers, the production of MAE in China reported in questionnaires accounts for approximately *** percent of overall production of MAE in China and *** percent of total exports to the United States of MAE produced in China.⁵ Table VII-1 presents information on the MAE operations of the responding producers/exporters in China.

³ These firms were identified through a review of information submitted in the petition and contained in ***.

⁴ A foreign producer questionnaire was submitted on behalf of U.S. producer JLG, which also submitted a U.S. producer questionnaire. The capacity, production, and shipment quantities reported in the foreign producer questionnaire only reflect JLG's wholly owned subsidiary in China, Oshkosh JLG (Tianjin) Equipment Technology Company. Ltd., thus, the firm associated with its foreign producer questionnaire is referred to as “JLG Tianjin.”

⁵ Petitioner notes that SANY Global, Xuzhou Construction Machinery Group Co. Ltd. (“XCMG”), and Zoomlion Heavy Industry Science & Technology did not submit foreign producer questionnaire responses and are some of the largest construction equipment manufacturers in the world. Petitioner's postconference brief, p.7. SANY America, the U.S.-based subsidiary of SANY global ***, reported ***. Emails from ***, March 17-18, 2021. XCMG North America's importer questionnaire response reported importing ***. Zoomlion Anhui Industrial Vehicle ***. Other firms identified in importer questionnaires as U.S. importers' sources of MAE from China for which we did not receive a foreign producer questionnaire include ***.

Table VII-1
MAE: Summary data for producers in China, 2020

Firm	Production (units)	Share of reported production (percent)	Exports to the United States (units)	Share of reported exports to the United States (percent)	Total shipments (units)	Share of firm's total shipments exported to the United States (percent)
Dingli	***	***	***	***	***	***
Hunan Sinoboom	***	***	***	***	***	***
JLG Tianjin	***	***	***	***	***	***
Lingong	***	***	***	***	***	***
Mantall	***	***	***	***	***	***
Terex Changzhou	***	***	***	***	***	***
All firms	***	***	***	***	***	***

Source: Compiled from data submitted in response to Commission questionnaires.

Changes in operations

As presented in table VII-2, producers in China reported several operational and organizational changes since January 1, 2018. Producers reported four expansions, two increases in production capabilities, one plant closing, and one revised labor agreement.

Table VII-2
MAE: Reported changes in operations by producers in China, since January 1, 2018

Item / Firm	Reported changed in operations
Plant closings:	
***	***
Expansions:	
***	***
***	***
***	***
***	***
Revised labor agreements:	
***	***
Other:	
***	***
***	***

Source: Compiled from data submitted in response to Commission questionnaires.

Four of the six foreign producers reported that the COVID-19 pandemic had an impact on their firm operations. Two reported supply chain disruptions, including delays in importing materials to China and shipping MAE to the U.S. (***), one reported declining sales (***), and one reported production shutdowns in the first quarter of 2020 (***) .

Operations on MAE

Table VII-3 presents information on the MAE operations of the responding producers/exporters in China. Capacity, production, and home market shipments all increased over the 2018-20 period, by ***, ***, and *** percent, respectively; while export shipments to the U.S. and all other markets decreased, by *** and *** percent, respectively. All of the aforementioned indicators, with the exception of export shipments to the U.S., are projected to be higher in 2021 than in any year during 2018-20,⁶ and are all projected to increase further between 2021 and 2022.⁷

Given that capacity increased more than production over the 2018-20 period, capacity utilization decreased by *** percentage points during this period, but is projected to increase by *** percentage points from 2021 to 2022.

Home market shipments increased as a share of total shipments by *** percentage points during 2018-20, and are projected to decrease by *** percentage points from 2021 to 2022. Export shipments to the U.S. and export shipments to all other markets (***), as a share of total shipments, both decreased during 2018-20, by *** and *** percentage points, respectively. The vast majority of export shipments to the U.S. were of complete units of MAE.⁸

End-of-period inventories increased by *** percent from 2018 to 2019, and increased by *** percent from 2019 to 2020, for a total increase of *** percent during 2018-20.⁹ Inventories are projected to increase by *** percent from 2021 to 2022. The ratio of inventories to total shipments increased by *** percentage points during 2018-20.

⁶ From 2020 to 2021, exports to all other markets are projected to increase by *** percent, home market shipments by *** percent, production by *** percent, and capacity by *** percent. Exports to the U.S. are projected to decrease by *** percent from 2020 to 2021.

⁷ From 2021 to 2022, exports to all other markets are projected to increase by *** percent, production by *** percent, home market shipments by *** percent, and capacity by *** percent.

⁸ Exports of subassemblies to the U.S. were reported by ***. U.S. importers reported importing *** subassemblies in 2018, *** subassemblies in 2019, and *** subassemblies in 2020. However, three of the U.S. importers (***) that reported subassembly imports listed Chinese producers that did not submit a foreign producer questionnaire as sources for these subassembly imports, including ***.

⁹ End-of-period inventories increased during 2018-20 for *** of the six responding Chinese producers, with *** reporting the highest increases over the period (*** percent, respectively).

Table VII-3

MAE: Data for producers in China, 2018-20 and projection calendar years 2021 and 2022

Item	Actual experience			Projections	
	Calendar year			Calendar year	
	2018	2019	2020	2021	2022
	Quantity (units)				
Capacity	***	***	***	***	***
Production	***	***	***	***	***
End-of-period inventories	***	***	***	***	***
Shipments:					
Home market shipments:					
Internal consumption/ transfers	***	***	***	***	***
Commercial home market shipments	***	***	***	***	***
Total home market shipments	***	***	***	***	***
Export shipments to US:					
Subassemblies	***	***	***	***	***
Complete MAE	***	***	***	***	***
Total US exports	***	***	***	***	***
All other markets	***	***	***	***	***
Total exports	***	***	***	***	***
Total shipments	***	***	***	***	***
	Ratios and shares (percent)				
Capacity utilization	***	***	***	***	***
Inventories/production	***	***	***	***	***
Inventories/total shipments	***	***	***	***	***
Share of shipments:					
Home market shipments:					
Internal consumption/ transfers	***	***	***	***	***
Commercial home market shipments	***	***	***	***	***
Total home market shipments	***	***	***	***	***
Export shipments to:					
Subassemblies	***	***	***	***	***
Complete MAE	***	***	***	***	***
Total US exports	***	***	***	***	***
All other markets	***	***	***	***	***
Total exports	***	***	***	***	***
Total shipments	***	***	***	***	***

Source: Compiled from data submitted in response to Commission questionnaires.

Alternative products

Table VII-4 presents other products Chinese firms produce on the same equipment and machinery used to produce MAE. ***, reported producing *** on the same equipment as MAE. Overall capacity increased by *** percent and capacity utilization ranged from *** to *** percent from 2018 to 2020.

Table VII-4
MAE: Overall capacity and production on the same equipment as in-scope production by producers in China, 2018-20

Item	Calendar year		
	2018	2019	2020
	Quantity (units)		
Overall capacity	***	***	***
Production: MAE	***	***	***
Out-of-scope production: Forklifts	***	***	***
Other products	***	***	***
All out-of-scope production	***	***	***
Total production on same machinery	***	***	***
	Ratios and shares (percent)		
Overall capacity utilization	***	***	***
Share of production: MAE	***	***	***
Share of out-of-scope production: Forklifts	***	***	***
Other products	***	***	***
All out-of-scope production	***	***	***
Total production on same machinery	***	***	***

Source: Compiled from data submitted in response to Commission questionnaires.

Exports

According to GTA, the leading export markets for forklift trucks and other lifting or handling work trucks, and parts thereof from China are the United States, Australia, and the Netherlands (table VII-5). During 2020, the United States was the top export market for such products from China, accounting for 17.5 percent of total value, followed by Australia, accounting for 5.3 percent of total value.

Table VII-5
Forklift trucks and other lifting or handling work trucks, and parts thereof: China exports by destination market, 2018-20

Destination market	Calendar year		
	2018	2019	2020
	Value (1,000 dollars)		
United States	751,792	576,906	558,313
Australia	227,840	201,561	170,144
Netherlands	229,865	187,760	159,929
Germany	157,053	147,052	141,323
Korea	125,391	144,098	120,198
Russia	102,217	114,403	118,322
Japan	139,559	160,406	108,725
France	106,575	101,573	96,929
Thailand	94,984	106,761	88,849
All other destination markets	1,807,093	1,748,629	1,633,445
All destination markets	3,742,369	3,489,149	3,196,177
	Share of value (percent)		
United States	20.1	16.5	17.5
Australia	6.1	5.8	5.3
Netherlands	6.1	5.4	5.0
Germany	4.2	4.2	4.4
Korea	3.4	4.1	3.8
Russia	2.7	3.3	3.7
Japan	3.7	4.6	3.4
France	2.8	2.9	3.0
Thailand	2.5	3.1	2.8
All other destination markets	48.3	50.1	51.1
All destination markets	100.0	100.0	100.0

Note.-- HS subheadings all include more products than those covered by the scope of these investigations. 8427.10 covers all self-propelled trucks with an electric motor, which includes various out of scope products, such as rider operated forklift trucks. 8427.20 covers all other self-propelled trucks which includes other types of rider operated forklifts and other trucks. 8427.90 covers all other trucks. 8431.20 covers parts of all machinery imported under the HS heading 8427.

Source: Official exports statistics under HS subheading 8427.10, 8427.20, 8427.90 and 8431.20 as reported by China customs in the Global Trade Atlas database, accessed March 26, 2021.

U.S. inventories of imported merchandise

Table VII-6 presents data on U.S. importers' reported inventories of MAE. End-of-period inventories of MAE from China decreased by *** percent from 2018 to 2019, then increased by *** percent from 2019 to 2020, for an overall *** decrease in inventories during 2018-20. The ratios of inventories of MAE from China to U.S. imports, U.S. shipments of imports, and total shipments of imports all increased over the 2018-20 period, from around one-sixth in 2018 to half in 2020.

End-of-period inventories from nonsubject sources increased by *** percent from 2018 to 2019, then decreased by *** percent from 2019 to 2020, for a total increase of *** percent from 2018 to 2020. End-of-period inventories from all sources increased *** percent over the 2018-20 period.

Table VII-6
MAE: U.S. importers' end-of-period inventories of imports by source, 2018-20

Item	Calendar year		
	2018	2019	2020
	Inventories (units); Ratios (percent)		
Imports from China Inventories	***	***	***
Ratio to U.S. imports	***	***	***
Ratio to U.S. shipments of imports	***	***	***
Ratio to total shipments of imports	***	***	***
Imports from nonsubject sources: Inventories	***	***	***
Ratio to U.S. imports	***	***	***
Ratio to U.S. shipments of imports	***	***	***
Ratio to total shipments of imports	***	***	***
Imports from all import sources: Inventories	***	***	***
Ratio to U.S. imports	***	***	***
Ratio to U.S. shipments of imports	***	***	***
Ratio to total shipments of imports	***	***	***

Source: Compiled from data submitted in response to Commission questionnaires.

U.S. importers' outstanding orders

The Commission requested U.S. importers to indicate whether they imported or arranged for the importation of MAE from China after December 31, 2019. *** of fifteen importers reported arranged imports from China after December 31, 2021, with the majority of arranged imports from China reported by *** (***) percent). *** of fifteen importers reported arranged imports from nonsubject sources after December 31, 2021, with the majority (***) percent) being reported by ***, followed by *** (***) percent).

Table VII-7
MAE: Arranged imports, January 2020 through December 2020

Item	Period				
	Jan-Mar 2021	Apr-Jun 2021	Jul-Sept 2021	Oct-Dec 2021	Total
	Quantity (units)				
Arranged U.S. imports from.--					
China	***	***	***	***	***
All other sources	***	***	***	***	***
All import sources	***	***	***	***	***

Source: Compiled from data submitted in response to Commission questionnaires.

Antidumping or countervailing duty orders in third-country markets

There are no known active antidumping or countervailing duty investigations or existing orders in third-country markets related to MAE.¹⁰

¹⁰ Petitioner is not aware of any antidumping duty, countervailing duty, or safeguard orders in place in any third-country market on MAE imports from China. No such trade measures have been reported to the World Trade Organization. Further, in their questionnaire responses, ***. Petitioner's postconference brief, exh. 1, p. 54.

Information on nonsubject countries

Data on global exports of forklift trucks and other lifting or handling work trucks, and parts thereof, during 2018-20, are presented in table VII-8. However, table VII-8 is based on official export statistics under HS subheadings 8427.10, 8427.20, 8427.90, and 8431.20, which contain significant amounts of out-of-scope product.

With regards to subject merchandise, Canada is the largest nonsubject exporter of MAE to the United States based on statements and information provided by petitioner and respondent MEC, in reference to Skyjack Inc. (“Skyjack Canada”), a Canadian producer of MAE. According to respondent MEC, Skyjack Canada is, by far, the largest importer of MAE into the U.S.¹¹ Petitioner states that Skyjack Canada is ***.¹² According to the 2019 Annual Report for Linamar, Skyjack Canada’s parent corporation, its market share in North America for telehandlers and boom products have increased since 2013 by six times and three times, respectively. Its boom market share has also tripled in Europe in that same time period.¹³

In Terex’s 2019 10-K statement form,¹⁴ it identified the following companies as its main global competitors for boom lifts, scissor lifts, and telehandlers, which suggest that France, the U.K., and Italy are also likely large global nonsubject exporters of MAE:

- **Boom lifts:** JLG (U.S.), Haulotte (France), Skyjack (Canada), Snorkel (U.S.), JCB (U.K.), and Aichi (Japan).
- **Scissor lifts:** JLG (U.S.), Skyjack (Canada), Haulotte (France), Manitou (France), JCB (U.K.) and Dingli (China).
- **Telehandlers:** JLG (U.S.), JCB (U.K.), CNH (Italy), Merlo (Italy), Manitou (France).

¹¹ Transcript, p. 12 (McConkey).

¹² Petition, exh. I-3.

¹³ Respondent MEC’s postconference brief, pp. 14-15 and exh. 1.

¹⁴ Chinese respondents’ postconference brief, exh. 2, p. 12.

Table VII-8
Forklift trucks and other lifting or handling work trucks, and parts thereof: Global exports by exporter, 2018-2020

Exporter	Calendar year		
	2018	2019	2020
	Value (1,000 dollars)		
United States	2,806,680	2,702,421	1,973,427
China	3,742,369	3,489,149	3,196,177
Germany	4,587,321	4,530,393	3,763,906
Italy	2,027,879	2,043,267	1,576,793
France	1,532,826	1,526,298	1,176,633
United Kingdom	1,446,833	1,433,938	1,409,571
Sweden	1,354,634	1,360,581	1,157,099
Japan	1,293,343	1,092,356	948,696
Canada	1,027,021	935,328	529,663
Netherlands	864,123	967,598	875,527
South Korea	812,297	776,503	591,988
Belgium	749,412	730,328	679,499
All other exporters	3,936,422	4,294,181	3,222,748
All reporting exporters	26,181,159	25,882,341	21,101,728
	Share of value (percent)		
United States	10.7	10.4	9.4
China	14.3	13.5	15.1
Germany	17.5	17.5	17.8
Italy	7.7	7.9	7.5
France	5.9	5.9	5.6
United Kingdom	5.5	5.5	6.7
Sweden	5.2	5.3	5.5
Japan	4.9	4.2	4.5
Canada	3.9	3.6	2.5
Netherlands	3.3	3.7	4.1
South Korea	3.1	3.0	2.8
Belgium	2.9	2.8	3.2
All other exporters	15.0	16.6	15.3
All reporting exporters	100.0	100.0	100.0

Note: HS subheadings all include more products than those covered by the scope of these investigations. 8427.10 covers all self-propelled trucks with an electric motor, which includes various out of scope products, such as rider operated forklift trucks. 8427.20 covers all other self-propelled trucks which includes other types of rider operated forklifts and other trucks. 8427.90 covers all other trucks. 8431.20 covers parts of all machinery imported under the HS heading 8427.

Source: Official exports statistics under HS subheading 8427.10, 8427.20, 8427.90 and 8431.20 as reported by various national statistical authorities in the Global Trade Atlas database, accessed March 26th, 2021.

APPENDIX A

FEDERAL REGISTER NOTICES

The Commission makes available notices relevant to its investigations and reviews on its website, www.usitc.gov. In addition, the following tabulation presents, in chronological order, *Federal Register* notices issued by the Commission and Commerce during the current proceeding.

Citation	Title	Link
86 FR 12711, March 4, 2021	<i>Mobile Access Equipment From China; Institution of Antidumping and Countervailing Duty Investigations and Scheduling of Preliminary Phase Investigations</i>	https://www.govinfo.gov/content/pkg/FR-2021-03-04/pdf/2021-04439.pdf
86 FR 15905, March 25, 2021	<i>Certain Mobile Access Equipment and Subassemblies Thereof From the People's Republic of China: Initiation of Countervailing Duty Investigation</i>	https://www.govinfo.gov/content/pkg/FR-2021-03-25/pdf/2021-06181.pdf
86 FR 15922, March 25, 2021	<i>Certain Mobile Access Equipment and Subassemblies Thereof From the People's Republic of China: Initiation of Less-Than-Fair-Value Investigation</i>	https://www.govinfo.gov/content/pkg/FR-2021-03-25/pdf/2021-06180.pdf

APPENDIX B

LIST OF STAFF CONFERENCE WITNESSES

CALENDAR OF PUBLIC PRELIMINARY CONFERENCE

Those listed below appeared in the United States International Trade Commission's preliminary conference via videoconference:

Subject: Mobile Access Equipment from China
Inv. Nos.: 701-TA-665 and 731-TA-1557 (Preliminary)
Date and Time: March 19, 2021 - 9:30 a.m.

OPENING REMARKS:

In Support of Imposition (**Laura El-Sabaawi**, Wiley Rein LLP)
In Opposition to Imposition (**Matthew McConkey**, Mayer Brown LLP)

In Support of the Imposition of Antidumping and Countervailing Duty Orders:

Wiley Rein LLP
Washington, DC
on behalf of

Coalition of American Manufacturers of Mobile Access Equipment

Jeff Ford, Director, Global Strategy and Business Development,
JLG Industries, Inc.

Tim Morris, Senior Vice President of Sales, Market Development
and Customer Support Americas, JLG Industries, Inc.

Oleg Malin, Director, Global Trade and Customs, Terex Corporation

Josh Meyer, Vice President, Global Sales, Terex Aerial Work Platforms

Timothy C. Brightbill)
Laura El-Sabaawi) – OF COUNSEL
Stephanie M. Bell)

**In Opposition to the Imposition of
Antidumping and Countervailing Duty Orders:**

Mayer Brown LLP
Washington, DC
on behalf of

California Manufacturing and Engineering Co. (“MEC”)

Deanne Hix, Vice President of Sales, Operations & Strategic Planning, MEC

Matthew McConkey)
) – OF COUNSEL
Anjani Nadadur)

Grunfeld, Desiderio, Lebowitz, Silverman & Klestadt LLP
Washington, DC
on behalf of

Zhejiang Dingli Machinery Co., Ltd.
Lingong Group Jinan Heavy Machinery Co., Ltd.
Hunan Sinoboom Intelligent Equipment Co.
Mantall Heavy Industry Co.
LGMG North America Inc.

Craig Paylor, President and Chief Executive Officer,
LGMG North America Inc.

Kolin Kirschenmann, Chief Executive Officer, Sinoboom North America LLC

Will Crumley, Co-Owner, Crumley Brothers LLC d/b/a M&R
Equipment Rental and Sales

Jordan C. Kahn)
Max F. Schutzman) – OF COUNSEL
Kavita Mohan)

REBUTTAL/CLOSING REMARKS:

In Support of Imposition

(**Timothy C. Brightbill**, Wiley Rein LLP)

In Opposition to Imposition

(**Jordan C. Kahn**, Grunfeld, Desiderio, Lebowitz, Silverman & Klestadt LLP)

-END-

APPENDIX C
SUMMARY DATA

Contents

Table C-1	MAE: Summary data concerning the U.S. market, 2018-20.....	C-3
Table C-2	MAE: Summary data concerning the U.S. market excluding one U.S. producer ***, 2018-20	C-6

Table C-1

MAE: Summary data concerning the U.S. market, 2018-20

(Quantity=units; Value=1,000 dollars; Unit values, unit labor costs, and unit expenses=dollars per unit; Period changes=percent-exceptions noted)

	Reported data			Period changes		
	Calendar year			Comparison years		
	2018	2019	2020	2018-20	2018-19	2019-20
U.S. consumption quantity (units):						
Amount.....	***	***	***	***	***	***
Producers' share (fn1).....	***	***	***	***	***	***
Importers' share (fn1):						
China.....	***	***	***	***	***	***
Nonsubject sources.....	***	***	***	***	***	***
All import sources.....	***	***	***	***	***	***
U.S. consumption quantity (short tons):						
Amount.....	***	***	***	***	***	***
Producers' share (fn1).....	***	***	***	***	***	***
Importers' share (fn1):						
China.....	***	***	***	***	***	***
Nonsubject sources.....	***	***	***	***	***	***
All import sources.....	***	***	***	***	***	***
U.S. consumption value:						
Amount.....	***	***	***	***	***	***
Producers' share (fn1).....	***	***	***	***	***	***
Importers' share (fn1):						
China.....	***	***	***	***	***	***
Nonsubject sources.....	***	***	***	***	***	***
All import sources.....	***	***	***	***	***	***
U.S. importers' U.S. shipments of imports from:						
China:						
Quantity (units).....	***	***	***	***	***	***
Quantity (short tons).....	***	***	***	***	***	***
Value.....	***	***	***	***	***	***
Unit value based on units.....	***	***	***	***	***	***
Unit value based on short tons.....	***	***	***	***	***	***
Ending inventory (units).....	***	***	***	***	***	***
Nonsubject sources:						
Quantity (units).....	***	***	***	***	***	***
Quantity (short tons).....	***	***	***	***	***	***
Value.....	***	***	***	***	***	***
Unit value based on units.....	***	***	***	***	***	***
Unit value based on short tons.....	***	***	***	***	***	***
Ending inventory (units).....	***	***	***	***	***	***

Table continued on next page.

Table C-1--Continued

MAE: Summary data concerning the U.S. market, 2018-20

(Quantity=units; Value=1,000 dollars; Unit values, unit labor costs, and unit expenses=dollars per unit; Period changes=percent-exceptions noted)

	Reported data			Period changes		
	Calendar year			Comparison years		
	2018	2019	2020	2018-20	2018-19	2019-20
U.S. importers' U.S. shipments of imports from--Continued:						
All import sources:						
Quantity (units).....	***	***	***	***	***	***
Quantity (short tons).....	***	***	***	***	***	***
Value.....	***	***	***	***	***	***
Unit value based on units.....	***	***	***	***	***	***
Unit value based on short tons.....	***	***	***	***	***	***
Ending inventory (units).....	***	***	***	***	***	***
U.S. producers':						
Average capacity quantity.....	***	***	***	***	***	***
Production quantity.....	***	***	***	***	***	***
Capacity utilization (fn1).....	***	***	***	***	***	***
U.S. shipments:						
Quantity (units).....	***	***	***	***	***	***
Quantity (short tons).....	***	***	***	***	***	***
Value.....	***	***	***	***	***	***
Unit value based on units.....	***	***	***	***	***	***
Unit value based on short tons.....	***	***	***	***	***	***
Export shipments:						
Quantity (units).....	***	***	***	***	***	***
Value.....	***	***	***	***	***	***
Unit value based on units.....	***	***	***	***	***	***
Ending inventory (units).....	***	***	***	***	***	***
Inventories/total shipments (fn1).....	***	***	***	***	***	***
Production workers.....	***	***	***	***	***	***
Hours worked (1,000s).....	***	***	***	***	***	***
Wages paid (\$1,000).....	***	***	***	***	***	***
Hourly wages (dollars per hour).....	***	***	***	***	***	***
Productivity (units per 1,000 hours).....	***	***	***	***	***	***
Unit labor costs.....	***	***	***	***	***	***

Table continued on next page.

Table C-1--Continued

MAE: Summary data concerning the U.S. market, 2018-20

(Quantity=units; Value=1,000 dollars; Unit values, unit labor costs, and unit expenses=dollars per unit; Period changes=percent-exceptions noted)

	Reported data			Period changes		
	Calendar year			Comparison years		
	2018	2019	2020	2018-20	2018-19	2019-20
U.S. producers'--Continued:						
Net sales:						
Quantity (units).....	***	***	***	***	***	***
Value.....	***	***	***	***	***	***
Unit value.....	***	***	***	***	***	***
Cost of goods sold (COGS).....	***	***	***	***	***	***
Gross profit or (loss) (fn2).....	***	***	***	***	***	***
SG&A expenses.....	***	***	***	***	***	***
Operating income or (loss) (fn2).....	***	***	***	***	***	***
Net income or (loss) (fn2).....	***	***	***	***	***	***
Capital expenditures.....	***	***	***	***	***	***
Research and development expenses.....	***	***	***	***	***	***
Net assets.....	***	***	***	***	***	***
Unit COGS.....	***	***	***	***	***	***
Unit SG&A expenses.....	***	***	***	***	***	***
Unit operating income or (loss) (fn2).....	***	***	***	***	***	***
Unit net income or (loss) (fn2).....	***	***	***	***	***	***
COGS/sales (fn1).....	***	***	***	***	***	***
Operating income or (loss)/sales (fn1).....	***	***	***	***	***	***
Net income or (loss)/sales (fn1).....	***	***	***	***	***	***

Note.--Shares and ratios shown as "0.0" percent represent non-zero values less than "0.05" percent (if positive) and greater than "(0.05)" percent (if negative). Zeroes, null values, and undefined calculations are suppressed and shown as "--". Period changes preceded by a "+" represent an increase, while period changes preceded by a "-" represent a decrease.

fn1.--Reported data are in percent and period changes are in percentage points.

fn2.--Percent changes only calculated when both comparison values represent profits; The directional change in profitability provided when one or both comparison values represent a loss.

Source: Compiled from data submitted in response to Commission questionnaires.

Table C-2

MAE: Summary data concerning the U.S. market excluding one U.S. producer *, 2018-20**

(Quantity=units; Value=1,000 dollars; Unit values, unit labor costs, and unit expenses=dollars per unit; Period changes=percent-exceptions noted)

	Reported data			Period changes		
	Calendar year			Comparison years		
	2018	2019	2020	2018-20	2018-19	2019-20
U.S. consumption quantity (units):						
Amount.....	***	***	***	***	***	***
Producers' share (fn1)						
Included producers.....	***	***	***	***	***	***
Excluded producers.....	***	***	***	***	***	***
All producers.....	***	***	***	***	***	***
Importers' share (fn1):						
China.....	***	***	***	***	***	***
Nonsubject sources.....	***	***	***	***	***	***
All import sources.....	***	***	***	***	***	***
U.S. consumption quantity (short tons):						
Amount.....	***	***	***	***	***	***
Producers' share (fn1)						
Included producers.....	***	***	***	***	***	***
Excluded producers.....	***	***	***	***	***	***
All producers.....	***	***	***	***	***	***
Importers' share (fn1):						
China.....	***	***	***	***	***	***
Nonsubject sources.....	***	***	***	***	***	***
All import sources.....	***	***	***	***	***	***
U.S. consumption value:						
Amount.....	***	***	***	***	***	***
Producers' share (fn1)						
Included producers.....	***	***	***	***	***	***
Excluded producers.....	***	***	***	***	***	***
All producers.....	***	***	***	***	***	***
Importers' share (fn1):						
China.....	***	***	***	***	***	***
Nonsubject sources.....	***	***	***	***	***	***
All import sources.....	***	***	***	***	***	***
U.S. importers' U.S. shipments of imports from:						
China:						
Quantity (units).....	***	***	***	***	***	***
Quantity (short tons).....	***	***	***	***	***	***
Value.....	***	***	***	***	***	***
Unit value based on units.....	***	***	***	***	***	***
Unit value based on short tons.....	***	***	***	***	***	***
Ending inventory (units).....	***	***	***	***	***	***

Table continued on next page.

Table C-2--Continued

MAE: Summary data concerning the U.S. market excluding one U.S. producer *, 2018-20**

(Quantity=units; Value=1,000 dollars; Unit values, unit labor costs, and unit expenses=dollars per unit; Period changes=percent-exceptions noted)

	Reported data			Period changes		
	Calendar year			Comparison years		
	2018	2019	2020	2018-20	2018-19	2019-20
U.S. importers' U.S. shipments of imports from--Continued:						
Nonsubject sources:						
Quantity (units).....	***	***	***	***	***	***
Quantity (short tons).....	***	***	***	***	***	***
Value.....	***	***	***	***	***	***
Unit value based on units.....	***	***	***	***	***	***
Unit value based on short tons.....	***	***	***	***	***	***
Ending inventory (units).....	***	***	***	***	***	***
All import sources:						
Quantity (units).....	***	***	***	***	***	***
Quantity (short tons).....	***	***	***	***	***	***
Value.....	***	***	***	***	***	***
Unit value based on units.....	***	***	***	***	***	***
Unit value based on short tons.....	***	***	***	***	***	***
Ending inventory (units).....	***	***	***	***	***	***
Included U.S. producers':						
Average capacity quantity.....	***	***	***	***	***	***
Production quantity.....	***	***	***	***	***	***
Capacity utilization (fn1).....	***	***	***	***	***	***
U.S. shipments:						
Quantity (units).....	***	***	***	***	***	***
Quantity (short tons).....	***	***	***	***	***	***
Value.....	***	***	***	***	***	***
Unit value based on units.....	***	***	***	***	***	***
Unit value based on short tons.....	***	***	***	***	***	***
Export shipments:						
Quantity (units).....	***	***	***	***	***	***
Value.....	***	***	***	***	***	***
Unit value based on units.....	***	***	***	***	***	***
Ending inventory (units).....	***	***	***	***	***	***
Inventories/total shipments (fn1).....	***	***	***	***	***	***
Production workers.....	***	***	***	***	***	***
Hours worked (1,000s).....	***	***	***	***	***	***
Wages paid (\$1,000).....	***	***	***	***	***	***
Hourly wages (dollars per hour).....	***	***	***	***	***	***
Productivity (units per 1,000 hours).....	***	***	***	***	***	***
Unit labor costs.....	***	***	***	***	***	***

Table continued on next page.

Table C-2--Continued

MAE: Summary data concerning the U.S. market excluding one U.S. producer *, 2018-20**

(Quantity=units; Value=1,000 dollars; Unit values, unit labor costs, and unit expenses=dollars per unit; Period changes=percent-exceptions noted)

	Reported data			Period changes		
	Calendar year			Comparison years		
	2018	2019	2020	2018-20	2018-19	2019-20
Included U.S. producers'--Continued:						
Net sales:						
Quantity (units).....	***	***	***	***	***	***
Value.....	***	***	***	***	***	***
Unit value.....	***	***	***	***	***	***
Cost of goods sold (COGS).....	***	***	***	***	***	***
Gross profit or (loss) (fn2).....	***	***	***	***	***	***
SG&A expenses.....	***	***	***	***	***	***
Operating income or (loss) (fn2).....	***	***	***	***	***	***
Net income or (loss) (fn2).....	***	***	***	***	***	***
Capital expenditures.....	***	***	***	***	***	***
Research and development expenses.....	***	***	***	***	***	***
Net assets.....	***	***	***	***	***	***
Unit COGS.....	***	***	***	***	***	***
Unit SG&A expenses.....	***	***	***	***	***	***
Unit operating income or (loss) (fn2).....	***	***	***	***	***	***
Unit net income or (loss) (fn2).....	***	***	***	***	***	***
COGS/sales (fn1).....	***	***	***	***	***	***
Operating income or (loss)/sales (fn1).....	***	***	***	***	***	***
Net income or (loss)/sales (fn1).....	***	***	***	***	***	***

Note.--Shares and ratios shown as "0.0" percent represent non-zero values less than "0.05" percent (if positive) and greater than "(0.05)" percent (if negative). Zeroes, null values, and undefined calculations are suppressed and shown as "--". Period changes preceded by a "+" represent an increase, while period changes preceded by a "-" represent a decrease.

fn1.--Reported data are in percent and period changes are in percentage points.

fn2.--Percent changes only calculated when both comparison values represent profits; The directional change in profitability provided when one or both comparison values represent a loss.

Source: Compiled from data submitted in response to Commission questionnaires.

APPENDIX D

SEMI-FINISHED PRODUCT ANALYSIS

Table D-1
MAE: U.S. producers' narratives regarding semi-finished analysis

Item / Firm	Narrative
U.S. producers: Other uses	
***	***
U.S. producers: Separate market	
***	***
***	***
U.S. producers: Differences in characteristics	
***	***
***	***
***	***
U.S. producers: Differences in cost	
***	***
***	***
***	***
***	***
U.S. producers: Transformation intensive	
***	***
***	***
***	***
***	***

Source: Compiled from data submitted in response to Commission questionnaires.

Note: *** reported ***.

Table D-2
MAE: U.S. importers' narratives regarding semi-finished analysis

Item / Firm	Narrative
U.S. importers: Other uses	
***	***
U.S. importers: Separate market	
***	***
***	***
***	***
U.S. importers: Differences in characteristics	
***	***
***	***
***	***
***	***
***	***
U.S. importers: Differences in cost	
***	***
***	***
***	***
***	***
***	***
U.S. importers: Transformation intensive	
***	***
***	***
***	***
***	***
***	***

Source: Compiled from data submitted in response to Commission questionnaires.

Note: *** reported ***.

APPENDIX E
AVERAGE UNIT VALUE ANALYSIS

Table E-1
MAE: U.S. producers' range of AUVs for complete MAE

Firm	Average unit value of US shipments, 2020 (dollars per unit)	Lowest AUV product		Highest volume product		Highest AUV product	
		Price (dollars per unit)	Description	Price (dollars per unit)	Description	Price (dollars per unit)	Description
***	***	***	***	***	***	***	***
***	***	***	***	***	***	***	***
***	***	***	***	***	***	***	***
***	***	***	***	***	***	***	***
***	***	***	***	***	***	***	***
***	***	***	***	***	***	***	***

Source: Compiled from data submitted in response to Commission questionnaires.

Note: Prices shown as "0" represent values greater than zero, but less than \$0.50.

Table E-2
MAE: U.S. producers' range of AUVs for subassemblies

Firm	Average unit value of US shipments, 2020 (dollars per unit)	Lowest AUV product		Highest volume product		Highest AUV product	
		Price (dollars per unit)	Description	Price (dollars per unit)	Description	Price (dollars per unit)	Description
***	***	***	***	***	***	***	***
***	***	***	***	***	***	***	***
***	***	***	***	***	***	***	***
***	***	***	***	***	***	***	***

Source: Compiled from data submitted in response to Commission questionnaires.

Note: Prices shown as "0" represent values greater than zero, but less than \$0.50.

Note: U.S. producers were asked to provide the range of per gross unit value for the different MAE and subassembly types used or sold by their firm since January 1, 2018. Since U.S. producers reported *** during the period of investigations, staff believe that the products presented in this table ***.

Table E-3
MAE: U.S. importers' range of AUVs for complete MAE

Firm	Average unit value of US shipments, 2020 (dollars per unit)	Lowest AUV product		Highest volume product		Highest AUV product	
		Price (dollars per unit)	Description	Price (dollars per unit)	Description	Price (dollars per unit)	Description
***	***	***	***	***	***	***	***
***	***	***	***	***	***	***	***
***	***	***	***	***	***	***	***
***	***	***	***	***	***	***	***
***	***	***	***	***	***	***	***
***	***	***	***	***	***	***	***
***	***	***	***	***	***	***	***

Table continued on next page.

Table E-3--Continued
MAE: U.S. importers' range of AUVs for complete MAE

Firm	Average unit value of US shipments, 2020 (dollars per unit)	Lowest AUV product		Highest volume product		Highest AUV product	
		Price (dollars per unit)	Description	Price (dollars per unit)	Description	Price (dollars per unit)	Description
***	***	***	***	***	***	***	***
***	***	***	***	***	***	***	***
***	***	***	***	***	***	***	***
***	***	***	***	***	***	***	***
***	***	***	***	***	***	***	***

Table continued on next page.

Table E-3--Continued
MAE: U.S. importers' range of AUVs for complete MAE

Firm	Average unit value of US shipments, 2020 (dollars per unit)	Lowest AUV product		Highest volume product		Highest AUV product	
		Price (dollars per unit)	Description	Price (dollars per unit)	Description	Price (dollars per unit)	Description
***	***	***	***	***	***	***	***
***	***	***	***	***	***	***	***
***	***	***	***	***	***	***	***

Source: Compiled from data submitted in response to Commission questionnaires.

Note: Prices shown as "0" represent values greater than zero, but less than \$0.50.

Table E-4
MAE: U.S. importers' range of AUVs for subassemblies

Firm	Average unit value of US shipments, 2020 (dollars per unit)	Lowest AUV product		Highest volume product		Highest AUV product	
		Price (dollars per unit)	Description	Price (dollars per unit)	Description	Price (dollars per unit)	Description
***	***	***	***	***	***	***	***
***	***	***	***	***	***	***	***
***	***	***	***	***	***	***	***
***	***	***	***	***	***	***	***
***	***	***	***	***	***	***	***

Source: Compiled from data submitted in response to Commission questionnaires.

Note: Prices shown as "0" represent values greater than zero, but less than \$0.50.

APPENDIX F

U.S. IMPORTERS' IMPORTS OF MAE SUBASSEMBLIES, BY TYPE¹

¹ U.S. producers only reported U.S. shipments of complete MAE, thus, only U.S. importer data are presented in Appendix F.

Table F-1
MAE: U.S. importers' imports from China, by product type, 2018-20

Item	Calendar year		
	2018	2019	2020
	Quantity (units)		
U.S importers: China			
Complete MAE	***	***	***
Scissor arms subassemblies	***	***	***
Boom subassemblies	***	***	***
Chassis subassemblies	***	***	***
Turntable subassemblies	***	***	***
All other subassemblies	***	***	***
All subassemblies	***	***	***
All product types	***	***	***
	Quantity (short tons)		
U.S importers: China			
Complete MAE	***	***	***
Scissor arms subassemblies	***	***	***
Boom subassemblies	***	***	***
Chassis subassemblies	***	***	***
Turntable subassemblies	***	***	***
All other subassemblies	***	***	***
All subassemblies	***	***	***
All product types	***	***	***
	Value (1,000 dollars)		
U.S importers: China			
Complete MAE	***	***	***
Scissor arms subassemblies	***	***	***
Boom subassemblies	***	***	***
Chassis subassemblies	***	***	***
Turntable subassemblies	***	***	***
All other subassemblies	***	***	***
All subassemblies	***	***	***
All product types	***	***	***
Scissor arms subassemblies	***	***	***
Boom subassemblies	***	***	***
Chassis subassemblies	***	***	***
Turntable subassemblies	***	***	***
All other subassemblies	***	***	***
All subassemblies	***	***	***
All product types	***	***	***

Table continued on next page.

Table F-1--Continued
MAE: U.S. importers' imports from China, by product type, 2018-20

Item	Calendar year		
	2018	2019	2020
	Unit value (dollars per unit)		
U.S importers: China Complete MAE	***	***	***
Scissor arms subassemblies	***	***	***
Boom subassemblies	***	***	***
Chassis subassemblies	***	***	***
Turntable subassemblies	***	***	***
All other subassemblies	***	***	***
All subassemblies	***	***	***
All product types	***	***	***
	Unit value (dollars per short ton)		
U.S importers: China Complete MAE	***	***	***
Scissor arms subassemblies	***	***	***
Boom subassemblies	***	***	***
Chassis subassemblies	***	***	***
Turntable subassemblies	***	***	***
All other subassemblies	***	***	***
All subassemblies	***	***	***
All product types	***	***	***
	Ratio (short ton per unit)		
U.S importers: China Complete MAE	***	***	***
Scissor arms subassemblies	***	***	***
Boom subassemblies	***	***	***
Chassis subassemblies	***	***	***
Turntable subassemblies	***	***	***
All other subassemblies	***	***	***
All subassemblies	***	***	***
All product types	***	***	***

Table continued on next page.

Table F-1--Continued
MAE: U.S. importers' imports from China, by product type, 2018-20

Item	Calendar year		
	2018	2019	2020
	Share of quantity based on units (percent)		
U.S importers: China Complete MAE	***	***	***
Scissor arms subassemblies	***	***	***
Boom subassemblies	***	***	***
Chassis subassemblies	***	***	***
Turntable subassemblies	***	***	***
All other subassemblies	***	***	***
All subassemblies	***	***	***
All product types	***	***	***
	Share of quantity based on short tons (percent)		
U.S importers: China Complete MAE	***	***	***
Scissor arms subassemblies	***	***	***
Boom subassemblies	***	***	***
Chassis subassemblies	***	***	***
Turntable subassemblies	***	***	***
All other subassemblies	***	***	***
All subassemblies	***	***	***
All product types	***	***	***
	Share of value (percent)		
U.S importers: China Complete MAE	***	***	***
Scissor arms subassemblies	***	***	***
Boom subassemblies	***	***	***
Chassis subassemblies	***	***	***
Turntable subassemblies	***	***	***
All other subassemblies	***	***	***
All subassemblies	***	***	***
All product types	***	***	***

Source: Compiled from data submitted in response to Commission questionnaires.

Note: Shares and ratios shown as "0.0" represent values greater than zero, but less than "0.05" percent.

Table F-2
MAE: U.S. importers' imports from nonsubject sources, by product type, 2018-20

Item	Calendar year		
	2018	2019	2020
	Quantity (units)		
U.S importers: Nonsubject sources			
Complete MAE	***	***	***
Scissor arms subassemblies	***	***	***
Boom subassemblies	***	***	***
Chassis subassemblies	***	***	***
Turntable subassemblies	***	***	***
All other subassemblies	***	***	***
All subassemblies	***	***	***
All product types	***	***	***
	Quantity (short tons)		
U.S importers: Nonsubject sources			
Complete MAE	***	***	***
Scissor arms subassemblies	***	***	***
Boom subassemblies	***	***	***
Chassis subassemblies	***	***	***
Turntable subassemblies	***	***	***
All other subassemblies	***	***	***
All subassemblies	***	***	***
All product types	***	***	***
	Value (1,000 dollars)		
U.S importers: Nonsubject sources			
Complete MAE	***	***	***
Scissor arms subassemblies	***	***	***
Boom subassemblies	***	***	***
Chassis subassemblies	***	***	***
Turntable subassemblies	***	***	***
All other subassemblies	***	***	***
All subassemblies	***	***	***
All product types	***	***	***

Table continued on next page.

Table F-2--Continued

MAE: U.S. importers' imports from nonsubject sources, by product type, 2018-20

Item	Calendar year		
	2018	2019	2020
	Unit value (dollars per unit)		
U.S importers: Nonsubject sources Complete MAE	***	***	***
Scissor arms subassemblies	***	***	***
Boom subassemblies	***	***	***
Chassis subassemblies	***	***	***
Turntable subassemblies	***	***	***
All other subassemblies	***	***	***
All subassemblies	***	***	***
All product types	***	***	***
	Unit value (dollars per short ton)		
U.S importers: Nonsubject sources Complete MAE	***	***	***
Scissor arms subassemblies	***	***	***
Boom subassemblies	***	***	***
Chassis subassemblies	***	***	***
Turntable subassemblies	***	***	***
All other subassemblies	***	***	***
All subassemblies	***	***	***
All product types	***	***	***
	Ratio (short ton per unit)		
U.S importers: Nonsubject sources Complete MAE	***	***	***
Scissor arms subassemblies	***	***	***
Boom subassemblies	***	***	***
Chassis subassemblies	***	***	***
Turntable subassemblies	***	***	***
All other subassemblies	***	***	***
All subassemblies	***	***	***
All product types	***	***	***

Table continued on next page.

Table F-2--Continued

MAE: U.S. importers' imports from nonsubject sources, by product type, 2018-20

Item	Calendar year		
	2018	2019	2020
	Share of quantity based on units (percent)		
U.S importers: Nonsubject sources			
Complete MAE	***	***	***
Scissor arms subassemblies	***	***	***
Boom subassemblies	***	***	***
Chassis subassemblies	***	***	***
Turntable subassemblies	***	***	***
All other subassemblies	***	***	***
All subassemblies	***	***	***
All product types	***	***	***
	Share of quantity based on short tons (percent)		
U.S importers: Nonsubject sources			
Complete MAE	***	***	***
Scissor arms subassemblies	***	***	***
Boom subassemblies	***	***	***
Chassis subassemblies	***	***	***
Turntable subassemblies	***	***	***
All other subassemblies	***	***	***
All subassemblies	***	***	***
All product types	***	***	***
	Share of value (percent)		
U.S importers: Nonsubject sources			
Complete MAE	***	***	***
Scissor arms subassemblies	***	***	***
Boom subassemblies	***	***	***
Chassis subassemblies	***	***	***
Turntable subassemblies	***	***	***
All other subassemblies	***	***	***
All subassemblies	***	***	***
All product types	***	***	***

Source: Compiled from data submitted in response to Commission questionnaires.

Note: Shares and ratios shown as "0.0" represent values greater than zero, but less than "0.05" percent.

